

FESTA[®]

PROFESIONÁLNE  NÁRADIE

20

23

24





Značka kvalitného ručného náradia pre stavbu dielňu aj záhradu



Značka profesionálnych vodováh



Značka profesionálnych vodováh a kvalitných lát



Ucelená skupina batériových produktov využívajúca kvalitné komponenty, najnovšie technológie a aktuálne trendy v batériovom náradí



Profesionálny zavlažovací sortiment s moderným designom, kompatibilný s radom produktov Rosa



Kvalitného zavlažovacie systémy a záhradné náradie



Japonské nože s dlhoročnou tradíciou



Profesionálne meradlá



Profesionálne rezačky obkladov



Výrobca kvalitných záhradných nožníc



Profesionálne stavebné miešačky



Profesionálne skrutkovacie nástavce



Značka profesionálnych plátok

AKU NÁRADIE

2 - 23



4 10 11 12 13 13 14 15 15 18

MERADLÁ

24 - 57



26 28 31 32 34 35 38 43 44 46 50 56

DIELENSKÉ NÁRADIE

58 - 159



60 70 73 87 101 115 122 129 131 136 140 144 149 155

VRTÁKY, REZNÉ A BRÚSNE NÁSTROJE

160 - 241



162 173 178 181 184 194 198 209 210 214 219 222 228 234

STAVEBNÉ NÁRADIE

242 - 329

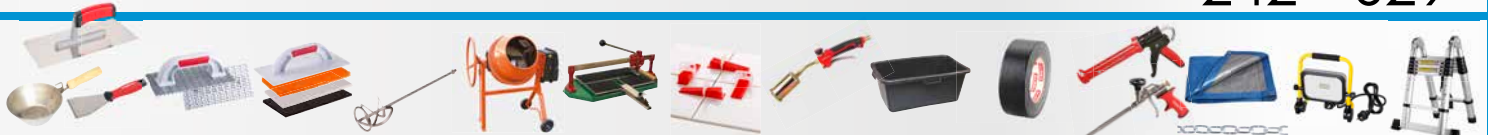

244 256 261 266 272 280 287 300 304 306 310 322 327 328

ZÁHRADNÉ NÁRADIE

330 - 397



332 343 345 346 348 364 365 367 372 381 387 389 394 395

ŽELEZIARSKY TOVAR

398 - 431



400 404 406 409 411 412 413 415 417 418 420 426

AUTODOPLNKY

432 - 443

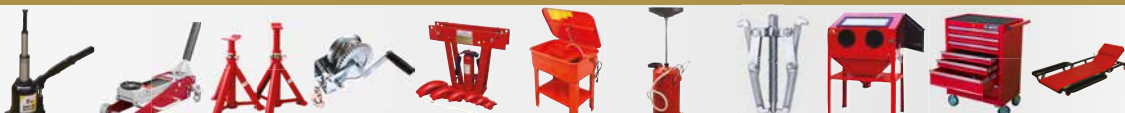

434 435 436 438 439 440 440 441 441 442 443

REGISTER

444 - 456

FESTA

POWER X TOOLS

SHARE
20V

Li-ion
technology



AKU NÁRADIE

2 - 23



BRUSHLESS **SHARE** **20V** *Li-ion*
technology

otáčky
0-550 min⁻¹
0-2000 min⁻¹

hmotnosť
s batériou 2,0 Ah **1,8 kg**
s batériou 4,0 Ah **2,1 kg**

krútiaci moment
80 Nm

skľučovadlo
2 – 13 mm



Sada obsahuje:
- vŕtačku
- batériu 2,0 Ah
- batériu 4,0 Ah
- nabíjačku 2,4 A
- prídavnú rukoväť
- kufor



FESTA
POWER X TOOLS

VŔTAČKA AKU PRÍKLEPOVÁ



Č.p. 28000
špecifikácia

2

BRUSHLESS **SHARE**
20V *Li-ion technology*



voľba režimu
voľba sily krútiaceho momentu

otáčky
0-550 min⁻¹
0-2000 min⁻¹

hmotnosť
s batériou 2,0 Ah **1,8 kg**
s batériou 4,0 Ah **2,1 kg**

krútiaci moment
80 Nm

skľučovadlo
2 – 13 mm

Sada obsahuje:
- vrtáčku
- batériu 2,0 Ah
- nabíjačku 2,4 A
- prídavnú rukoväť
- kufor



prídavná rukoväť

rýchlopínacie
skľučovadlo

ergonomická pogumovaná
rukoväť pre pohodlný
a bezpečný úchop

LED osvetlenie

aretácia batérie



prepínač rýchlosti

prepínač
smeru otáčania

háčik
na zavesenie

FESTA
POWER X TOOLS

VRTAČKA AKU PRÍKLEPOVÁ

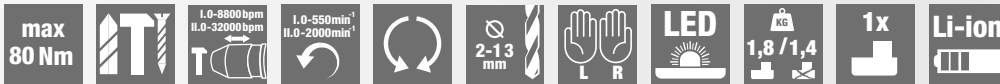

Č.p. špecifikácia

28001

2

BRUSHLESS **SHARE**
20V



voľba režimu
voľba sily krútiaceho momentu

otáčky
0-550 min⁻¹
0-2000 min⁻¹

hmotnosť
bez batérie
1,4 kg

krútiaci moment
80 Nm

skľučovadlo
2 – 13 mm

Odporúčame príslušenstvo

28080 Batéria 2,0 Ah

28081 Batéria 4,0 Ah

28085 Nabíjačka 2,4 A

28086 Nabíjačka 4,0 A



prídavná rukoväť

rýchlopínacie
skľučovadlo

ergonomická pogumovaná
rukoväť pre pohodlný
a bezpečný úchop

LED osvetlenie



prepínač rýchlosti

prepínač
smeru otáčania

háčik na zavesenie

FESTA
POWER X TOOLS

VRTAČKA AKU PRÍKLEPOVÁ



*batéria nie je súčasťou balenia

Č.p. špecifikácia

28002

5

SHARE
20V

Li-ion
technology

otáčky
0-500 min⁻¹
0-1800 min⁻¹

hmotnosť
s batériou 2,0 Ah
1,7 kg

krútiaci moment
45 Nm

skľučovadlo
2 – 13 mm

Sada obsahuje:
- vŕtačku
- 2x batériu 2,0 Ah
- nabíjačku 2,4 A
- kufor
- unášač a bity:
⊖ S5, S6 x 25 mm
⊕ PH1, PH2 x 25 mm
⊕ PZ1, PZ2 x 25 mm
- vrtáky HSS
2-2,5-3-4-5-6 mm



voľba režimu
voľba sily krútiaceho momentu

prepínač rýchlosti

rýchlopínacie
skľučovadlo

prepínač
smeru otáčania

ergonomická pogumovaná
rukoväť pre pohodlný
a bezpečný úchop

LED osvetlenie

háčik
na zavesenie

aretácia batérie



FESTA
POWER X TOOLS

VŔTAČKA AKU PRÍKLEPOVÁ



Č.p. špecifikácia

28003

3

SHARE
20V

otáčky
0-550 min⁻¹
0-2000 min⁻¹

hmotnosť
bez batérie
1,4 kg

krútiaci moment
80 Nm

skľučovadlo
2 – 13 mm

Odporúčame príslušenstvo

28080 Batéria 2,0 Ah

28081 Batéria 4,0 Ah

28085 Nabíjačka 2,4 A

28086 Nabíjačka 4,0 A



voľba režimu
voľba sily krútiaceho momentu

prepínač rýchlosti

rýchlopínacie
skľučovadlo

ergonomická pogumovaná
rukoväť pre pohodlný
a bezpečný úchop

LED osvetlenie

háčik
na zavesenie



FESTA
POWER X TOOLS

VŔTAČKA AKU PRÍKLEPOVÁ



*batéria nie je súčasťou balenia

Č.p. špecifikácia

28004

5

SHARE
20V *Li-ion*
technology

otáčky
0-350 min⁻¹
0-1300 min⁻¹

hmotnosť
s batériou 2,0 Ah
1,3 kg

krútiaci moment
28 Nm

skľučovadlo
1 – 10 mm

- Sada obsahuje:
- vŕtačku
 - 2x batériu 2,0 Ah
 - nabíjačku 2,4 A
 - kufor
 - unášač a bity:
 - ⊖ S5, S6 x 25 mm
 - ⊕ PH1, PH2 x 25 mm
 - ⊕ PZ1, PZ2 x 25 mm
 - vrtáky HSS
 - 1,5-2,5-3-4-5-6 mm



voľba režimu
voľba sily krútiaceho momentu

rýchlopínacie
skľučovadlo

prepínač rýchlosti

prepínač
smeru otáčania

ergonomická pogumovaná
rukoväť pre pohodlný
a bezpečný úchop

LED osvetlenie

aretácia batérie

háčik
na zavesenie



VŔTAČKA AKU



Č.p. špecifikácia

28005

3

SHARE
20V

otáčky
0-350 min⁻¹
0-1300 min⁻¹

hmotnosť
bez batérie
0,9 kg

krútiaci moment
28 Nm

skľučovadlo
1 – 10 mm

Odporúčame príslušenstvo

28080 Batéria 2,0 Ah

28081 Batéria 4,0 Ah

28085 Nabíjačka 2,4 A

28086 Nabíjačka 4,0 A



voľba režimu
voľba sily krútiaceho momentu

rýchlopínacie
skľučovadlo

prepínač rýchlosti

prepínač
smeru otáčania

ergonomická pogumovaná
rukoväť pre pohodlný
a bezpečný úchop

LED osvetlenie

háčik
na zavesenie



VŔTAČKA AKU



*batéria nie je súčasťou balenia

Č.p. špecifikácia

28006

5

Li-ion
technology

otáčky
0-350 min⁻¹
0-1300 min⁻¹

hmotnosť
s batériou 1,5 Ah
1 kg

krútiaci moment
20 Nm

skľučovadlo
1 - 10 mm

Sada obsahuje:

- vŕtačku
- 2x batériu 12 V | 1,5 Ah
- nabíjačku 12 V | 2,4 A
- kufor
- unášač a bity:
- ⊖ S5, S6 x 25 mm
- ⊕ PH1, PH2 x 25 mm
- ✳ PZ1, PZ2 x 25 mm
- vŕtáky HSS
1,5-2,5-3-4-5-6 mm



voľba režimu
voľba sily krútiaceho momentu

rýchlopínacie
skľučovadlo

prepínač rýchlosti

LED osvetlenie

indikátor nabitia batérie

ergonomická pogumovaná
rukoväť pre pohodlný
a bezpečný úchopprepínač smeru
otáčania

batérie

**FESTA**
POWER X TOOLS

VŔTAČKA AKU



Č.p. špecifikácia

28007

5

Li-ion
technology

otáčky
bez zaťaženia
200 min⁻¹

hmotnosť
s batériou 1,5 Ah
0,4 kg

maximálny
krútiaci moment
3 Nm

unášač
nástroje
1/4" šesťhran

Sada obsahuje:

- skrutkovač
- nabíjačku 5 V | 0,5 A
- bity:
- ⊖ S5 x 50 mm
- ⊕ PH1 x 50 mm
- ⊕ PH2 x 50 mm
- H5 x 50 mm
- ✳ T20 x 50 mm

rýchlopínacia
hlava 1/4" s poistkounastavenie
krútiaceho momentu

indikátor nabitia batérie

aretácia nastavenia
polohy rukoväte

LED osvetlenie

prepínač smeru
otáčaniaergonomická pogumovaná
rukojeť pro pohodlný
a bezpečný úchop

LED svetidlo

FESTA
POWER X TOOLS

SKRUTKOVAČ AKU



Č.p. špecifikácia

28008

10

**SHARE
20V**



otáčky bez zaťaženia
0-2000 min⁻¹

hmotnosť bez batérie
1,2 kg

krútiaci moment
150 Nm

počet rázov
0-3000 bpm

rýchlopínacia hlava 1/4" s poistkou



voliteľný smer otáčania

ergonomická pogumovaná rukoväť pre pohodlný a bezpečný úchop

LED osvetlenie

háčik na zavesenie

Odporúčame príslušenstvo

28080 Batéria 2,0 Ah

28081 Batéria 4,0 Ah



28085 Nabíjačka 2,4 A

28086 Nabíjačka 4,0 A



UŤAHOVAČ AKU RÁZOVÝ



*batéria nie je súčasťou balenia

Č.p. špecifikácia

28021



5

**SHARE
20V**



otáčky bez zaťaženia
I.0-300 min⁻¹
II.0-1000 min⁻¹

hmotnosť bez batérie
1,7 kg

počet príklepov
0-5000 bpm

úchyt
SDS+

hlbkový doraz

prepínanie režimu práce (s / bez príklepu)

upínacia hlava SDS+

prepínač rýchlosti

prepínač smeru otáčania



Odporúčame príslušenstvo

28080 Batéria 2,0 Ah

28081 Batéria 4,0 Ah



28085 Nabíjačka 2,4 A

28086 Nabíjačka 4,0 A



KLADIVO VŔTACIE AKU



*batéria nie je súčasťou balenia

Č.p. špecifikácia

28025



2

SHARE
20V

- frekvencia nastreľovania
60-100 min⁻¹
- max. dĺžka klinčov / spôn
30 mm
- tvrdé materiály
- max. dĺžka klinčov / spôn
50 mm
- mäkké materiály
- hmotnosť bez batérie
2,7 kg



poistka

ergonomická pogumovaná rukoväť pre pohodlný a bezpečný úchop

poistka prevádzkového spínača

háčik na zavesenie

LED signalizácia porúch

prepínač režimu nastreľovania

Odporúčame príslušenstvo

- 28080 Batéria 2,0 Ah
- 28081 Batéria 4,0 Ah
- 28085 Nabíjačka 2,4 A
- 28086 Nabíjačka 4,0 A

Klince

- 23930 Klinec nastreľovací 30 mm, 2000 ks
- 23931 Klinec nastreľovací 40 mm, 2000 ks
- 23932 Klinec nastreľovací 50 mm, 2000 ks

Spony

- 23935 Spona nastreľovacia 30 mm, 2000 ks
- 23936 Spona nastreľovacia 40 mm, 2000 ks

Vhodné typy klinčov a spôn:

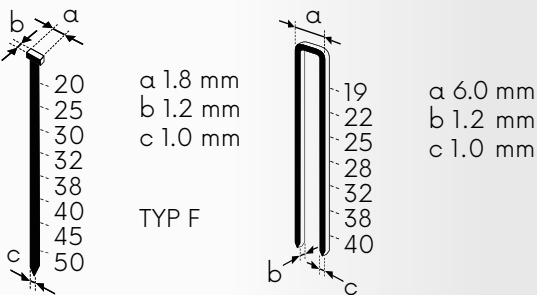

KLINCOVAČKA SPONKOVAČKA AKU

max 60 min⁻¹ | 1.8 mm / 1.2 mm / 1.0 mm | 6.0 mm / 1.2 mm / 1.0 mm | LED | 2,7 kg

*batéria nie je súčasťou balenia

Č.p. 28070 | špecifikácia



SHARE
20V

farebná teplota
6000 K

hmotnosť
bez batérie
1,6 kg

svetelný tok
1800 lm (100%)
1000 lm (60%)
500 lm (30%)

výkon LED
30W



nastavenie otočnej hlavy 360°

príruba pre montáž

nastavenie intenzity svetla
30%, 60%, 100%



Odporúčame príslušenstvo

28080 Batéria 2,0 Ah

28081 Batéria 4,0 Ah

28085 Nabíjačka 2,4 A

28086 Nabíjačka 4,0 A



ĽAD SVETLO AKU STAVEBNÉ



**batéria nie je súčasťou balenia

Č.p. špecifikácia

28065



**BRUSHLESS SHARE
20V**

otáčky
bez zaťaženia
8500 min⁻¹

hmotnosť
bez batérie
1,6 kg

maximálna hrúbka
rezaného materiálu
15 mm

maximálny
priemer kotúča
125 mm

vĕtrací otvory motoru

ergonomická pogumovaná
rukoväť pre pohodlný
a bezpečný úchop

aretace otáčení

pojistka
provozného
spínače**Odporúčame príslušenstvo**

28080 Batéria 2,0 Ah

28081 Batéria 4,0 Ah



28085 Nabíjačka 2,4 A

28086 Nabíjačka 4,0 A

rychloupínací
mechanismus
ochranného krytu

upínací matice kotouče

FESTA
POWER X TOOLS**BRÚSKA AKU**

*batéria a kotúč nie je súčasťou balenia

Č.p.
28030

špecifikácia



4

**SHARE
20V**

otáčky
bez zaťaženia
8000 min⁻¹

hmotnosť
bez batérie
1,6 kg

maximálna hrúbka
rezaného materiálu
15 mm

maximálny
priemer kotúča
115 mm

ergonomická pogumovaná
rukoväť pre pohodlný
a bezpečný úchoparetácia
otáčaniapoistka
prevádzkového
spínača**Odporúčame príslušenstvo**

28080 Batéria 2,0 Ah

28081 Batéria 4,0 Ah



28085 Nabíjačka 2,4 A

28086 Nabíjačka 4,0 A

rychloupínací
mechanismus
ochranného krytu

upínací matice kotouča

FESTA
POWER X TOOLS**BRÚSKA AKU**

*batéria a kotúč nie je súčasťou balenia

Č.p.
28032

špecifikácia



4

SHARE
20V



otáčky
bez zaťaženia
10000 min⁻¹

hmotnosť
bez batérie
1 kg

excentricita
kotúča
5 mm

priemer
kotúča
125 mm

prevádzkového spínača

zberný vak na prach

zabudované odsávanie

nosný kotúč so suchým zipsom



Odporúčame príslušenstvo

28080 Batéria 2,0 Ah
28081 Batéria 4,0 Ah



28085 Nabíjačka 2,4 A
28086 Nabíjačka 4,0 A



FESTA
POWER X TOOLS

BRÚSKA AKU EXCENTRICKÁ



*batéria nie je súčasťou balenia

Č.p. špecifikácia

28040



4

SHARE
20V

počet kmitov
bez zaťaženia
5000-15000 min⁻¹

hmotnosť
bez batérie
1 kg

regulácia otáčok

čap uchytenie nástroja

páka pre výmenu
a aretáciu nástroja

regulácia otáčok

ergonomická pogumovaná
rukoväť pre pohodlný
a bezpečný úchop



Odporúčame príslušenstvo

28080 Batéria 2,0 Ah
28081 Batéria 4,0 Ah



28085 Nabíjačka 2,4 A
28086 Nabíjačka 4,0 A



FESTA
POWER X TOOLS

BRÚSKA AKU MULTIFUNKČNA



*batéria nie je súčasťou balenia

Č.p. špecifikácia

28045



4

SHARE
20Vergonomická pogumovaná rukoväť
pre pohodlný a bezpečný úchop

poistka prevádzkového spínača

kryt kotúča

pripojenie
externého
odsávanianastavenie uhla
sklonu rezu
45-90 stupňov

základňa

hriadeľ 16 mm

stupnice
hĺbky rezuotáčky
bez zaťaženia
3650 min⁻¹nastaviteľný
uhol sklonu rezu
45-90 stupňovmax. priemer
kotúča
165 mm
(ø16 mm)max. prerez
50 mm* pri uhle 90 stupňov
s kotúčom ø165 mm

aretácia otáčania

nastavenie hĺbky rezu

Odporúčame príslušenstvo

28080 Batéria 2,0 Ah

28081 Batéria 4,0 Ah



28085 Nabíjačka 2,4 A

28086 Nabíjačka 4,0 A

FESTA
POWER X TOOLS

PÍLA AKU KOTÚČOVÁ



*batéria nie je súčasťou balenia

Č.p.

špecifikácia

28035 súčasťou balenia pílový kotúč ø165x16 mm 24T



vodiaca lišta



2

SHARE
20V



ergonomická pogumovaná rukoväť
pre pohodlný a bezpečný úchop

počet zdvihov
plátku
0-2400 min⁻¹

hmotnosť
bez batérie
1,8 kg

max. uhol
skosenie rezu
45 stupňov

max.
rezaný profil
ocel': 6 mm
drevo: 80 mm

poistka
prevádzkového
spínača

nastavenie predkmitu

osvetlenie

páčka
aretácia sklonu

Odporúčame príslušenstvo

28080 Batéria 2,0 Ah

28081 Batéria 4,0 Ah

28085 Nabíjačka 2,4 A

28086 Nabíjačka 4,0 A



aretácia lišty

základňa

vodiaca lišta



skosenie rezu

0°
45° 45°



PÍLA AKU PRIAMOČIARA



*batéria nie je súčasťou balenia

Č.p. špecifikácia

28050



4

SHARE
20V



poistka
prevádzkového
spínača

počet kmitov
bez zaťaženia
0-3000 min⁻¹

hmotnosť
bez batérie
1,7 kg

max. rezná hrúbka
drevo: 100 mm
ocel': 5 mm
hliník/meď: 20 mm

Odporúčame príslušenstvo

28080 Batéria 2,0 Ah

28081 Batéria 4,0 Ah

28085 Nabíjačka 2,4 A

28086 Nabíjačka 4,0 A



ergonomická pogumovaná rukoväť
pre pohodlný a bezpečný úchop

rýchlopínanie
pílového plátku



PÍLA AKU OCASKA



*batéria nie je súčasťou balenia

Č.p. špecifikácia

28055



4

SHARE
20V

Li-ion
technology

28004
str. 6

28032
str. 12

28055
str. 15

28035
str. 14

37330

28040
str. 13

ZVÝHODNENÁ
CENA
+TAŠKA ZADARMO

FESTA
POWER X TOOLS

AKU SET S TAŠKOU SADA 5+3

- 28004 - Vŕtačka AKU s príklepom FESTA SHARE20V
- 28032 - Brúška uhlová AKU FESTA SHARE20V 115 mm
- 28035 - Píla kotúčová AKU FESTA SHARE20V 165 mm/d 16 mm
- 28040 - Brúška excentrická AKU FESTA SHARE20V 125 mm 8 otv.
- 28055 - Píla ocaska AKU FESTA SHARE20V
- 28080 - Batérie do AKU náradie FESTA SHARE20V 2,0 Ah
- 28081 - Batérie do AKU náradie FESTA SHARE20V 4,0 Ah
- 28086 - Nabíjačka FESTA SHARE20V 4,0 A



28080
str. 18



28081
str. 18



28086
str. 18



Č.p. špecifikácia

28101



1

SHARE
20V

Li-ion
technology

BRUSHLESS

28002
str. 5

28030
str. 12

28040
str. 13

BRUSHLESS

28055
str. 15

37330

28035
str. 14

ZVÝHODNENÁ
CENA
+TAŠKA ZADARMO

FESTA
POWER X TOOLS

AKU SET S TAŠKOU SADA 5+3

- 28002 - Vŕtačka AKU s príklepom FESTA SHARE20V
- 28030 - Brúška uhlová AKU FESTA "BRUSHLESS" SHARE20V 125 mm
- 28035 - Píla kotúčová AKU FESTA SHARE20V 165 mm/d 16 mm
- 28040 - Brúška excentrická AKU FESTA SHARE20V 125 mm 8 otv.
- 28055 - Píla ocaska AKU FESTA SHARE20V
- 28080 - Batérie do AKU náradie FESTA SHARE20V 2,0 Ah
- 28081 - Batérie do AKU náradie FESTA SHARE20V 4,0 Ah
- 28086 - Nabíjačka FESTA SHARE20V 4,0 A

28080
str. 18



28081
str. 18



28086
str. 18



Č.p. špecifikácia

28104



1

SHARE
20V *Li-ion*
technology

ZVÝHODNENÁ
CENA
+ TAŠKA ZADARMO



FESTA
POWER X TOOLS

AKU SET S TAŠKOU SADA 3+3

- 28004 - Vrtáčka AKU s príklepom FESTA SHARE20V
- 28025 - Kladivo vrtacie AKU FESTA SDS+ SHARE20V
- 28030 - Brúška uhlová AKU FESTA "BRUSHLESS" SHARE20V 125 mm
- 28080 - Batérie do AKU náradia FESTA SHARE20V 2,0 Ah
- 28081 - Batérie do AKU náradia FESTA SHARE20V 4,0 Ah
- 28086 - Nabíjačka FESTA SHARE20V 4,0 A



Č.p.	špecifikácia	
28102		1

BRUSHLESS **SHARE**
20V *Li-ion*
technology

ZVÝHODNENÁ
CENA
+ TAŠKA ZADARMO



FESTA
POWER X TOOLS

AKU SET S TAŠKOU SADA 2+3

- 28002 - Vrtáčka AKU s príklepom FESTA SHARE20V
- 28030 - Brúška uhlová AKU FESTA "BRUSHLESS" SHARE20V 125 mm
- 28080 - Batérie do AKU náradia FESTA SHARE20V 2,0 Ah
- 28081 - Batérie do AKU náradia FESTA SHARE20V 4,0 Ah
- 28086 - Nabíjačka FESTA SHARE20V 4,0 A



Č.p.	špecifikácia	
28103		1

SHARE
20V



NABÍJAČKA 20 V I 24 A

Č.p.	špecifikácia
28085	220 – 240 V, 50 – 60 Hz, 70 W

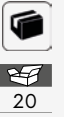

SHARE
20V



NABÍJAČKA 20 V I 4,0 A

Č.p.	špecifikácia
28086	*220 – 240 V, 50 – 60 Hz, 105 W

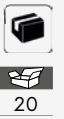

SHARE
20V *Li-ion technology*

indikátor nabitia batérie



BATÉRIA 20 V I 2,0 Ah

20V	2,0 Ah	Li-ion	KG 0,4
-----	--------	--------	--------

Č.p.	špecifikácia
28080	

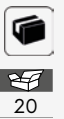

SHARE
20V *Li-ion technology*

indikátor nabitia batérie



BATÉRIA 20 V I 4,0 Ah

20V	4,0 Ah	Li-ion	KG 0,7
-----	--------	--------	--------

Č.p.	špecifikácia
28081	

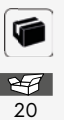

BRUSHLESS

náradie je poháňané
bezuhlíkovým
jednosmerným motorom

krútiaci moment	
otáčky	
voliteľný smer otáčania	
skľučovadlo	
vrtanie, vrtanie s príklepom, skrutkovanie	
počet úderov za minútu	
vrtanie, skrutkovanie	
hmotnosť s / bez batérie	
spôsob uchytenia	
spôsob uchytenia	
spôsob uchytenia	
excentricita kotúča	
ovládanie prístroja pre pravú aj ľavú ruku	
spĺňa uvedenú normu	
svetelný tok	
smerový uhol svetla	
maximálna frekvencia nastreľovania	

SHARE 20V

náradie je kompatibilné
s oboma batériami

	vhodné typy klinev
	vhodné typy spôn
	brúsny kotúč s otvormi
	maximálny priemer kotúča
	priemer kotúča
	maximálna rezná hrúbka materiál: drevo
	maximálna rezná hrúbka materiál: oceľ
	rychloupínanie píly
	uchytenie píly
	počet zdvihov píly
	nastavenie predkmitu
	uchytenie píly
	počet kmitov píly
	LED osvetlenie
	kapacita batérie
	batéria
	doba nabíjania batérie

TECHNICKÉ ŠPECIFIKÁCIE



KATALÓGOVÉ ČÍSLO PRODUKTU	28000	28001	28002	28003	28004
Názov	Vrtačka AKU s príklepom	Vrtačka AKU s príklepom	Vrtačka AKU s príklepom	Vrtačka AKU s príklepom	Vrtačka AKU s príklepom
Otáčky bez zaťaženia	I.0-550 min ⁻¹ II.0-2000 min ⁻¹	I.0-550 min ⁻¹ II.0-2000 min ⁻¹	I.0-550 min ⁻¹ II.0-2000 min ⁻¹	I.0-500 min ⁻¹ II.0-1800 min ⁻¹	I.0-500 min ⁻¹ II.0-1800 min ⁻¹
Počet príklepov	I.0-8800min ⁻¹ II.0-32000min ⁻¹	I.0-8800min ⁻¹ II.0-32000min ⁻¹	I.0-8800min ⁻¹ II.0-32000min ⁻¹	0-19200 min ⁻¹	0-19200 min ⁻¹
Počet rázov					
Krútiaci moment	80 Nm	80 Nm	80 Nm	45 Nm	45 Nm
Max. napätie akumulátora	20V	20V	20V	20V	20V
Počet stupňov krútiaceho momenta	20+1+1	20+1+1	20+1+1	19+1+1	19+1+1
Upínacia hlava	2-13 mm	2-13 mm	2-13 mm	2-13 mm	2-13 mm
Hmotnosť bez batérie	1,4kg	1,4kg	1,4kg	1,3kg	1,3kg
Krytie	IPX0	IPX0	IPX0	IPX0	IPX0
Hladina akustického hluku neistota K	LpA=97,04dB(A) K=5dB(A)	LpA=97,04dB(A) K=5dB(A)	LpA=97,04dB(A) K=5dB(A)	LpA=79dB(A) K=5dB(A)	LpA=79dB(A) K=5dB(A)
Hladina akustického výkonu neistota K	LwA=86,04dB(A) K=5dB(A)	LwA=86,04dB(A) K=5dB(A)	LwA=86,04dB(A) K=5dB(A)	LwA=90dB(A) K=5dB(A)	LwA=90dB(A) K=5dB(A)
Vibrácie bez príklepu do kovu	$a_{h,D}=3,9m/s^2$ K=1,5m/s ²	$a_{h,D}=3,9m/s^2$ K=1,5m/s ²	$a_{h,D}=3,9m/s^2$ K=1,5m/s ²	$a_{h,D}=2,4m/s^2$ K=1,5m/s ²	$a_{h,D}=2,4m/s^2$ K=1,5m/s ²
Vibrácie bez príklepu do betónu	$a_{h,ID}=11,4m/s^2$ K=1,5m/s ²	$a_{h,ID}=11,4m/s^2$ K=1,5m/s ²	$a_{h,ID}=11,4m/s^2$ K=1,5m/s ²	$a_{h,ID}=7,5m/s^2$ K=1,5m/s ²	$a_{h,ID}=7,5m/s^2$ K=1,5m/s ²
Maximálne vibrácie, neistota K					
Sila údera					
Priemer vrtania					
Vibrácie - vrtanie do betónu - hlavná rukoväť					
Vibrácie - vrtanie do betónu - prídavná rukoväť					
Obsah balenia	vrtačka, nabíjačka 2,4 A, batérie 2,0 Ah, batérie 4,0 Ah, prídavná rukoväť, kufor	vrtačka, nabíjačka 2,4 A, batérie 2,0 Ah, prídavná rukoväť, kufor	vrtačka	vrtačka, nabíjačka 2,4 A, 2x batéria 2,0 Ah, 6x bit, unášač, 6x vrták, kufor	vrtačka



28005	28006	28007	28008	28021	28025
Vŕtačka AKU	Vŕtačka AKU	Vŕtačka AKU	Skrutkovač AKU	Uťahovák AKU rázový	Kladivo vŕtacie AKU
I.0-350 min ⁻¹ II.0-1300 min ⁻¹	I.0-350 min ⁻¹ II.0-1300 min ⁻¹	I.0-350 min ⁻¹ II.0-1300 min ⁻¹	200 min ⁻¹	0-2000 min ⁻¹	I.0-300 min ⁻¹ II.0-1000 min ⁻¹
					0-5000bpm
					0-3000bpm
28 Nm	28 Nm	20 Nm	3 Nm	150 Nm	
20V	20V	12V	3.6V	20V	20V
19+1	19+1	19+1	6+1		
1-10mm	1-10mm	1-10mm	1/4" šesťhran	1/4" šesťhran	SDS+
0,9kg	0,9kg	*1kg	*0,4kg	1,2kg	1,7kg
IPX0	IPX0	IPX0	IPX0	IPX0	IPX0
LpA=69dB(A) K=5dB(A)	LpA=69dB(A) K=5dB(A)	LpA=78dB(A) K=5dB(A)	LpA=58dB(A) K=3dB(A)	LpA=92dB(A) K=3dB(A)	LpA=82,98dB(A) K=3dB(A)
LwA=80dB(A) K=5dB(A)	LwA=80dB(A) K=5dB(A)	LwA=67dB(A) K=5dB(A)	LwA=69dB(A) K=3dB(A)	LwA=103dB(A) K=3dB(A)	LwA=93,98dB(A) K=3dB(A)
$\alpha_{h,D} < 1,9m/s^2$ K=1,5m/s ²	$\alpha_{h,D} < 1,9m/s^2$ K=1,5m/s ²	$\alpha_{h,D} = 2,1m/s^2$ K=1,5m/s ²			
$\alpha_{h,D} = 10,1m/s^2$ K=1,5m/s ²	$\alpha_{h,D} = 10,1m/s^2$ K=1,5m/s ²	$\alpha_{h,D} = 7,5m/s^2$ K=1,5m/s ²			
			$\alpha_h < 2,5m/s^2$ K=1,5m/s ²	$\alpha_{h,D} = 15,9m/s^2$ K=1,5m/s ²	
					1,2J
					ocel':10mm beton: 20mm drevo: 20mm
					$\alpha_{h,(HD)} = 5,582m/s^2$ K=1,5m/s ²
					$\alpha_{h,(HD)} = 5,523m/s^2$ K=1,5m/s ²
vŕtačka, nabíjačka 2,4 A, 2x batéria 2,0 Ah, 6x bit, unášač, 6x vrták, kufor	vŕtačka	vŕtačka, nabíjačka 2,4 A, 2x batéria 1,5 Ah, 6x bity, unášač, 6x vrták, kufor	skrutkovač, nabíjačka 0,5 A, batérie 1,5 Ah, 5x bit	uťahovák	vŕtacie kladivo, prídavná rukoväť, hlbkový doraz

* hmotnosť je uvedená vrátane batérie

TECHNICKÉ ŠPECIFIKÁCIE



KATALÓGOVÉ ČÍSLO PRODUKTU	28030	28032	28035	28040
Názov	Brúska AKU	Brúska AKU	Píla AKU kotúčová	Brúska AKU excentrická
Otáčky bez zaťaženia	8500 min ⁻¹	8000 min ⁻¹	3650 min ⁻¹	10.000 min ⁻¹
Počet kmitov bez zaťaženia				
Predkmit				
Počet stupňov predkmitu				
Počet zdvihov pílového plátka				
Maximálna rezaný profil				
Maximálny priemer kotúča	125 mm	115 mm		
Nosný kotúč				125 mm
8 odsávacích otvorov na kružnici				65 mm
Excentricita kotúče				5 mm
Veľkosť závitov vretena	M14	M14		
Maximálna hrúbka rezaného materiálu	15 mm	15 mm		
Max. napätie akumulátora	20V	20V	20V	20V
Nastaviteľný uhol sklonu rezu			0-45°	
Prierez pri uhle 45°			35 mm	
Prierez pri uhle 90°			50 mm	
Uhol oscilácie				
Rozmer brúsnej základne				
Regulácia rýchlosti kmitania				
Uchytenie pílového plátka				
Zdvih pílového plátka				
Rozmer základovej dosky			28 cm x 13,3 cm	
Hmotnosť bez batérie	1,6kg	1,6kg	2,7kg	1kg
Priemer kotúča			165 mm	
Hrúbka tela kotúča			1,4 mm ± 5% mm	
Hrúbka SK plátka kotúča			2,0 ± 5% mm	
Šírka rezu			2,3 ± 5% mm	
Priemer otvoru kotúča po upnutie			16 mm	
Počet zubov kotúča			24	
Krytie	IPX0	IPX0	IPX0	IPX0
Klince - typ, výška x šírka x hrúbka				
Spony - rozpätie x výška x šírka x hrúbka				
Max. dĺžka klincov/spôn do mäkkých mat.				
Max. dĺžka klincov/spôn do tvrdých mat.				
Priemerná/max. frekvencia nastreľovania				
Doba prevádzky (batéria 4 AH, plne nabitá)				
Kapacita zásobníka klincov/spôn				
Hladina akustického hluku neistota K	LpA=87,1dB(A) K=3dB(A)	LpA=76,67dB(A) K=3dB(A)	LpA=84dB(A) K=3dB(A)	LpA=76dB(A) K=3dB(A)
Hladina akustického výkonu neistota K	LwA=98,1dB(A) K=3dB(A)	LwA=87,67dB(A) K=3dB(A)	LwA=95dB(A) K=3dB(A)	LwA=87dB(A) K=3dB(A)
Vibrácie pri brúsení povrchu	$a_{h,AG}=8,363m/s^2$ K=1,5m/s ²	$a_{h,AG}=5,324m/s^2$ K=1,5m/s ²		
Vibrácie pri rezanie dosky				
Vibrácie pri rezanie plechu				
Vibrácie pri rezanie drevených rámov				
Maximálne vibrácie, neistota K			$a_h < 2,5m/s^2$ K=1,5m/s ²	$a_h = 9,5m/s^2$ K=1,5m/s ²
Obsah balenia	brúska, kryt kotúča, prídavná rukoväť, kľúč	brúska, kryt kotúča, prídavná rukoväť, kľúč	píla, hlbkový doraz, pílový kotúč	brúska, zberný vak na prach



28045	28050	28055	28070
Brúska AKU multifunkčné	Píla AKU priamočiara	Píla AKU ocaska	Klincovačka / sponkovačka AKU
5000-15000 min ⁻¹		0-3000 min ⁻¹	
	3+0	1°	
	0-2400 min ⁻¹		
	ocel': 6mm, drevo: 80mm	drevo: 100 mm, ocel': 5 mm, hliník/meď: 20 mm	
20V		20V	20V
	Skosenie rezu max. 45°		
3°			
90 mm			
ANO			
univerzálne		univerzálne	
		20 mm	
1kg	1,8kg	1,7kg	2,7kg
IPX0	IPX0	IPX0	IPX0
			F, 20-50mm x 1,2mm x 1,0 mm
			6,0mm x 19-40mm x 1,2mm x 1,0mm
			50 mm
			30 mm
			60/100 min ⁻¹
			1 hodina
			100 kusov
LpA=78dB(A) K=3dB(A)	LpA=88,1dB(A) K=5dB(A)	LpA=87,33dB(A) K=5dB(A)	LpA=79,9dB(A) K=3dB(A)
LwA=89dB(A) K=3dB(A)	LwA=99,1dB(A) K=5dB(A)	LwA=98,33dB(A) K=5dB(A)	LwA=90,9dB(A) K=3dB(A)
	$a_{h,B}=3,3m/s^2$ $K=1,5m/s^2$ $a_{h,M}=4m/s^2$ $K=1,5m/s^2$	$a_{h,B}=21,10m/s^2$ $K=1,5m/s^2$	
		$a_{h,WB}=21,98m/s^2$ $K=1,5m/s^2$	
$a_h=2,8m/s^2$ $K=1,5m/s^2$			$a_h=1,39m/s^2$ $K=1,5m/s^2$
brúska, nástavce (pílka, škrabka, unášač), 3x brúsny papier P80	pílka, vodiaca lišta, nástavec pre odsávanie, 2x pílový list	píla, 2x pílový plátok	klincovačka / sponkovačka, 200x klince, 200x spony



MERADLÁ

24 - 57



26

ZVINOVACIE METRE A
PASMA KOMELON

28

ZVINOVACIE METRE FESTA



31

PÁSMA



32

SKLADACIE METRE



34

POSUVNÉ MERADLÁ



35

PRAVÍTKA A UHOLNÍKY



38

VODOVÁHY A LATY HORI-
ZONT

43

VODOVÁHY NIVELA



45

DIGITÁLNE VODOVÁHY A
UHLOMERY

46

LASEROVÉ MERADLÁ



50

CERUZKY A ZNAČKOVAČE



56

SPREJE



· VYSOKO PRESNÉ A KVALITNÉ MERADLÁ

KOMELON®

- II. trieda presnosti podľa STN 251104, EEC 755345
- Nylonový povrch pásku DURA NY Coat™ zaručuje desaťnásobne vyššiu odolnosť proti oteru stupnice

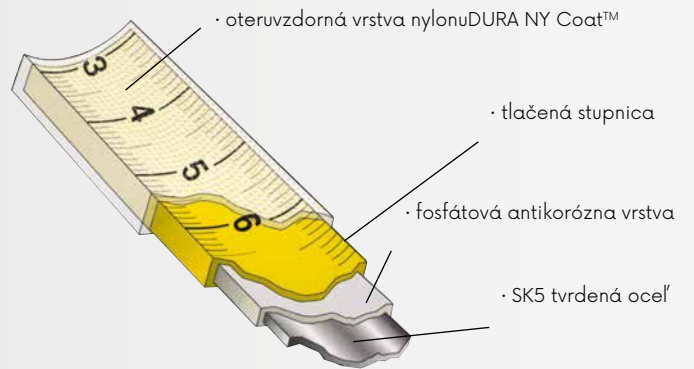

KOMELON® METER ZVINOVACÍ

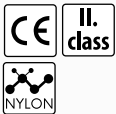

Č.p.	špecifikácia	
10002	2 m · 16 mm	10
10003	3 m · 16 mm	10
10005	5 m · 19 mm	10
10008	8 m · 25 mm	10

KOMELON® METER ZVINOVACÍ

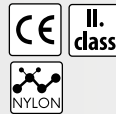

Č.p.	špecifikácia	
10025	5 m · 25 mm	10

KOMELON® METER ZVINOVACÍ

- automatická brzda
- protišmykové pogumovanie

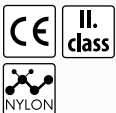

Č.p.	špecifikácia	
10033	3 m · 16 mm	6
10035	5 m · 19 mm	6

KOMELON® METER ZVINOVACÍ



Č.p.	špecifikácia	
10043	3 m · 16 mm	30
10045	5 m · 19 mm	30
10048	8 m · 25 mm	12

KOMELON®
PÁSMO
OCEĽOVÉ



Č.p.	špecifikácia	
10110	10 m · 10 mm	6
10120	20 m · 10 mm	6
10130	30 m · 10 mm	6

KOMELON®
PÁSMO
SKLOLAMINÁTOVÉ



Č.p.	špecifikácia	
10330	10 m · 13 mm	6
10332	20 m · 13 mm	6
10334	30 m · 13 mm	6
10336	50 m · 13 mm	6



KOMELON®
PÁSMO
SKLOLAMINÁTOVÉ



Č.p.	špecifikácia	
10430	30 m · 13 mm	1
10450	50 m · 13 mm	1
10490	100 m · 13 mm	1

KOMELON®
STOJAN NA METRE

· osadenie stojanu 10996

- 10003 · 5 ks
- 10005 · 4 ks
- 10008 · 1 ks
- 10033 · 2 ks
- 10035 · 3 ks
- 10045 · 2 ks
- 10025 · 3 ks
- 10110 · 1 ks
- 10120 · 1 ks
- 10130 · 1 ks
- 10430 · 1 ks
- 10330 · 1 ks
- 10332 · 1 ks
- 10334 · 1 ks
- 10336 · 1 ks



· ilustračné foto

Č.p.	špecifikácia	
10999	stojan na metre	1
10996	stojan na metre osadený	1



· Informácie o páske metra



- A** · dĺžka metra
- B** · trieda presnosti
- C** · vyhlásenie o zhode - CE
- D** · rok výroby
- E** · číslo akreditovanej skúšobne vydávajúcej certifikát
- F** · výrobca
- G** · špeciálna úprava pásky
- H** · teplota, pri ktorej bola skúška vykonávaná

STOJAN NA METRE

· ilustračné foto

Č.p.	špecifikácia	
10998		1

**FESTA®****METER ZVINOVACÍ**

- stupnica s veľkými číslami
- protišmykové pogumovanie
- nylonová vrstva



Č.p.	špecifikácia	
11353	3 m · 19 mm	12
11355	5 m · 19 mm	12
11356	5 m · 25 mm	12
11358	8 m · 25 mm	6
11360	10 m · 25 mm	6



· protišmykové pogumovanie PTE

· pútko

· automatická brzda

· pochromovaný, kovový záves

· ABS puzdro

· nylonová vrstva

FESTA®**METER ZVINOVACÍ**

Č.p.	špecifikácia	
11343	3 m · 16 mm	6
11345	5 m · 19 mm	6
11347	7,5 m · 25 mm	6

**FESTA®****METER ZVINOVACÍ - MAGNET**

- 3 x brzda
- magnetický háčik
- príbrzdenie
- protišmykové pogumovanie



Č.p.	špecifikácia	
11323	3 m · 16 mm	10
11325	5 m · 19 mm	10
11327	7,5 m · 25 mm	6

FESTA®**METER ZVINOVACÍ COMPACT**

- malý rozmer metra
- nylonová vrstva



Č.p.	špecifikácia	
11220	3 m · 16 mm	12
11221	5 m · 19 mm	12

**FESTA®****METER ZVINOVACÍ**

- stupnica s veľkými číslami

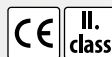

Č.p.	špecifikácia	
11226	2 m · 16 mm	10
11239	3 m · 19 mm	10
11259	5 m · 19 mm	10
11260	7,5 m · 25 mm	10



FESTA

METER ZVINOVACÍ MAGNETIC

- magnetický háčik
- protišmykové pogumovanie
- fluorescenčná páska
- stupnica s veľkými číslami



Č.p.	špecifikácia	
11102	2 m · 16 mm	10
11103	3 m · 16 mm	10
11105	5 m · 19 mm	12
11106	5 m · 25 mm	12
11107	7,5 m · 25 mm	10
11110	10 m · 25 mm	6



FESTA

METER ZVINOVACÍ

- automatická brzda
- protišmykové pogumovanie



Č.p.	špecifikácia	
11333	3 m · 16 mm	12
11335	5 m · 19 mm	12
11337	7,5 m · 25 mm	12
11338	10 m · 25 mm	12



Johnney

METER ZVINOVACÍ

- matná úprava pásky



Č.p.	špecifikácia	
11002	2 m · 13 mm	12
11003	3 m · 13 mm	12
11005	5 m · 13 mm	12
11006	5 m · 19 mm	12
11007	7,5 m · 19 mm	12
11008	10 m · 25 mm	12



METER ZVINOVACÍ - ERGO

- pribrzdenie
- protišmykové pogumovanie

Č.p.	špecifikácia	
11082	2 m · 16 mm	12
11083	3 m · 16 mm	12
11085	5 m · 19 mm	12



METER ZVINOVACÍ

- metrická a palcová stupnica
- protišmykové pogumovanie



Č.p.	špecifikácia	
11416	5 m · 19 mm	10

METER ZVINOVACÍ

- pribrzdenie

Č.p.	špecifikácia	
11200	2 m · 13 mm	24
11201	2 m · 16 mm	24
11202	2 m · 19 mm	24
11204	3 m · 13 mm	24
11205	3 m · 16 mm	24
11206	3 m · 19 mm	24
11207	5 m · 19 mm	12
11208	5 m · 25 mm	12
11209	7,5 m · 25 mm	12
11210	10 m · 25 mm	12



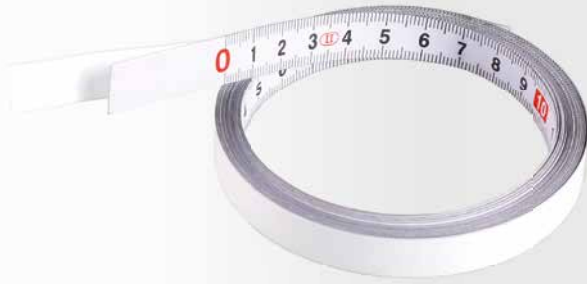

PÁSKA KOVOVÁ, MERACIA, PLOCHÁ, SAMOLEPIACA

II. class



Č.p.	špecifikácia	
11311	1 m · 12,5 mm	30
11312	2 m · 12,5 mm	30
11313	3 m · 16 mm	30
11314	5 m · 19 mm	30

METER ZVINOVACÍ S MENOM, 3M • 16 MM

CE II. class



Č.p.	meno na metru	Č.p.	meno na metru	Č.p.	meno na metru
13500	JIRÍ	13512	MICHAL	13524	ROMAN
13501	PETR	13513	MILAN	13525	ŠIKULA
13502	JOSEF	13514	KAREL	13526	RADEK
13503	TOMÁŠ	13515	VLADIMÍR	13527	MISTR
13504	JAN	13516	DĚDEČEK	13528	ONDŘEJ
13505	MARTIN	13517	MŮJ METR	13529	MAREK
13506	JAROSLAV	13518	VÁCLAV	13530	STANISLAV
13507	FRANTIŠEK	13519	JAKUB	13531	BOREC
13508	PAVEL	13520	LUKÁŠ	13532	TATÍNEK
13509	MIROSLAV	13521	2X MĚŘ	13533	ANTONÍN
13510	BIG BOSS	13522	LADISLAV	13534	ALEŠ
13511	ZDENĚK	13523	DAVID		



FESTA

METER ZVINOVACÍ - PRÍVESOK

- stupnica s veľkými číslami
- charakteristiky plnohodnotného metra

II. class

MOQ 12

Č.p.	špecifikácia	
11410	2 m · 16 mm 6 barev	12

METER ZVINOVACÍ - PRÍVESOK

Č.p.	špecifikácia	
11420	1 m · 6 mm oranžový	24



METER ZVINOVACÍ PRÍVESOK

Č.p.	špecifikácia	
11444	1 m · 6 mm biely	20

METER ZVINOVACÍ PRÍVESOK

Č.p.	špecifikácia	
11425	1 m · 6 mm	25

LIBELA - PRÍVESOK

Č.p.	špecifikácia	
11445		100



FESTA

PÁSMO OCEĽOVÉ

· oko



Č.p.	špecifikácia	
12010	10 m · 10 mm	1
12020	20 m · 10 mm	1
12030	30 m · 10 mm	1
12050	50 m · 10 mm	6



FESTA

PÁSMO SKLOLAMINÁTOVÉ

· oko



Č.p.	špecifikácia	
12110	10 m · 13 mm	6
12120	20 m · 13 mm	1
12130	30 m · 13 mm	1
12150	50 m · 13 mm	1



FESTA

PÁSMO OCEĽOVÉ

· oko + háčik



Č.p.	špecifikácia	
12210	10 m · 10 mm	6
12220	20 m · 10 mm	6
12230	30 m · 10 mm	6
12250	50 m · 10 mm	6



FESTA

PÁSMO OCEĽOVÉ

· oko



Č.p.	špecifikácia	
12433	30 m · 12,5 mm	20
12435	50 m · 12,5 mm	10



MERACIE KOLESO

- odolné, ľahké a kompaktné
- počítadlo pridáva pri pohybe vpred a odčíta pri pohybe vzad
- zabudované osvetlenie pre nočnú prácu, 2 AAA batérie v držadle
- vrátane puzdra



Č.p.	špecifikácia	
15989	max. 10 km	2



FESTA

MERACIA TELESKOPICKÁ TYČ

· vrátane puzdra

Č.p.	špecifikácia	
15983	0,7 - 3 m	10
15985	1,1 - 5 m	10
15988	1,6 - 8 m	5

SKLADACÍ METER

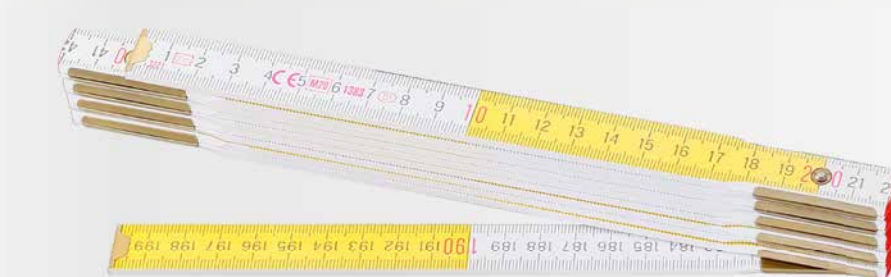

Č.p.	špecifikácia	
13010	1 m · biely	20
13020	2 m · biely	10
13021	1 m · žltý	20
13022	2 m · žltý	10
13023	2 m · bielo - žltý	10

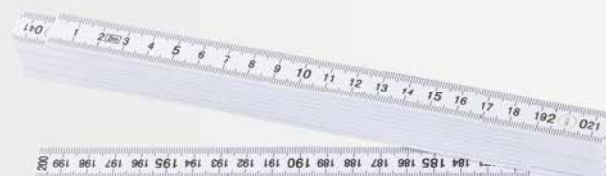

SKLADACÍ METER



Č.p.	špecifikácia	
13111	1 m · žltý	10
13120	2 m · žltý	5

SKLADACÍ METER



Č.p.	špecifikácia	
13210	1 m · mini	10
13211	1 m	1
13220	2 m	1



SKLADACÍ METER S MENOM



Č.p.	meno na metru	Č.p.	meno na metru	
13401	JIŘÍ	13426	DANIEL	10
13402	JAN	13427	ANTONÍN	
13403	PETR	13428	VOJTĚCH	Č.p.
13404	JOSEF	13429	FILIP	meno na metru
13405	PAVEL	13430	ADAM	13451
13406	MARTIN	13431	MILOSLAV	JANA
13407	JAROSLAV	13432	MATĚJ	13452
13408	TOMÁŠ	13433	ALEŠ	EVA
13409	MIROSLAV	13434	JAROMÍR	13453
13410	ZDENĚK	13435	LIBOR	PETRA
13411	FRANTIŠEK	13436	DOMINIK	13454
13412	VÁCLAV	13437	PATRIK	MAJKA
13413	MICHAL	13438	VLASTIMIL	13455
13414	MILAN	13439	JINDŘICH	HANA
13415	KAREL	13440	MILOŠ	13456
13416	JAKUB	13441	JÁN	ANNA
13417	DAVID	13442	PETER	13457
13418	LUKÁŠ	13443	ONDREJ	LENKA
13419	VLADIMÍR	13444	JOZEF	13458
13420	LADISLAV	13445	PAVOL	KATKA
13421	ONDŘEJ	13446	L'UBOMÍR	13459
13422	ROMAN	13447	KAROL	LUCIE
13423	STANISLAV	13448	RADOSLAV	13460
13424	MAREK	13449	VOJTĚCH	ALENA
13425	RADEK	13450	ZDENKO	13461
				VERONIKA
				13462
				MARTINA
				13463
				JITKA
				13464
				BIG BOSS
				13465
				2 x MĚŘ
				13466
				TATÍNEK
				13467
				DĚDEČEK
				13468
				ŠIKULA
				13469
				MISTR
				13470
				MACHR
				13471
				BOREC
				13472
				UŽ JE MŮJ
				13473
				MŮJ METR

STOJAN NA METRE

· osadenie stojanu 13399

- 13401 · 15 ks
- 13402 · 15 ks
- 13403 · 15 ks
- 13404 · 15 ks
- 13405 · 15 ks
- 13406 · 15 ks
- 13412 · 15 ks
- 13413 · 15 ks
- 13414 · 15 ks
- 13415 · 15 ks
- 13416 · 15 ks
- 13417 · 15 ks
- 13418 · 15 ks
- 13419 · 15 ks
- 13420 · 15 ks
- 13421 · 10 ks
- 13422 · 10 ks
- 13423 · 10 ks
- 13424 · 10 ks
- 13425 · 10 ks
- 13426 · 10 ks
- 13427 · 10 ks
- 13428 · 10 ks
- 13429 · 10 ks
- 13430 · 10 ks
- 13431 · 10 ks
- 13432 · 10 ks
- 13433 · 10 ks
- 13434 · 10 ks
- 13435 · 10 ks
- 13436 · 10 ks
- 13437 · 10 ks
- 13438 · 10 ks
- 13439 · 10 ks
- 13440 · 10 ks



Č.p.	špecifikácia	
13399	stojan na metre osadený	1
13400	stojan na metre	1

FESTA

MERADLO S RUKOVÄŤOU

ALU



· 2 x libela

Č.p.	špecifikácia	
14030	600 mm	6

FESTA

MERADLO HLINÍKOVÉ

ALU



Č.p.	špecifikácia	
14015	400 mm	48
14017	600 mm	50
14019	1000 mm	40

FESTA

MERADLO OCEĽOVÉ

INOX

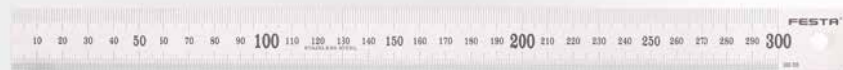

Č.p.	špecifikácia	
14010	300 mm	10
14011	600 mm	20
14012	1000 mm	20

**FESTA**

MERADLO POSUVNÉ

INOX



Č.p.	špecifikácia	
14007	150 0,01 mm	10
14008	200 0,01 mm	10
14009	300 0,01 mm	10



MERADLO POSUVNÉ DIGITÁLNE FIBERGLASS

· presnosť 0,2 mm, rozlíšenie 0,1 mm

Č.p.	špecifikácia	
14013	150 0,2 mm	10

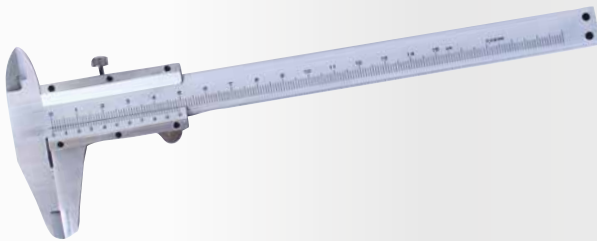
**FESTA**

MERADLO POSUVNÉ

INOX

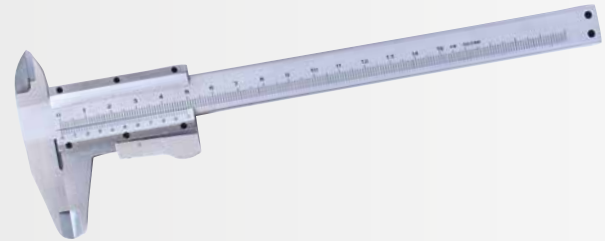

Č.p.	špecifikácia	
14001	150 0,02 mm	10
14002	200 0,02 mm	10
14003	300 0,02 mm	10

**FESTA**

MERADLO POSUVNÉ

INOX



Č.p.	špecifikácia	
14004	150 0,02 mm	10

**FESTA**

MIKROMETER



Č.p.	špecifikácia	
14040	0 - 0,25 0,01 mm	10
14045	25 - 50 0,01 mm	10



MERADLO POSUVNÉ

HOBBY



Č.p.	špecifikácia	
14006	150 mm	50

**FESTA**

ÚCHYLKOMETER

INOX



Č.p.	špecifikácia	
14035	0 - 10mm 0,01 mm	10



ŠKÁROVÉ MIERKY

· 20 listů



Č.p.	špecifikácia	
14080	0,05 - 1 mm	10



FESTA

UHLOMER S OTOČNÝM RAMENOM

· vrátane puzdra

INOX

Č.p.	špecifikácia	
14060	0° - 180° · 150 x 200 mm	5
14070	0° - 180° · 300 x 500 mm	7

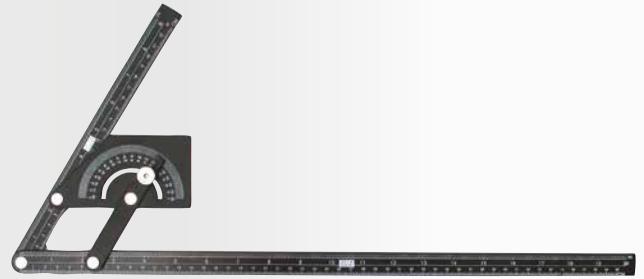

UHLOMER

HOBBY

Č.p.	špecifikácia	
14075	0° - 180° · 230 x 500 mm	30

NEW



MERADLO VIACÚČELOVÉ

No.	Specification	
14077		1



MERADLO VIACÚČELOVÉ

PLASTIC

Č.p.	špecifikácia	
14480	250 x 120 mm	1



ŠABLÓNÁ NA KOPÍROVANIE TVAROV

PLASTIC

Č.p.	špecifikácia	
14090	125 x 30 mm	1
14091	250 x 30 mm	1



FESTA

UHOLNÍK STOLÁRSKY
MULTIFUNKČNÝ

ALU

Č.p.	špecifikácia	
14420	180 mm	10
14421	300 mm	10

NEW

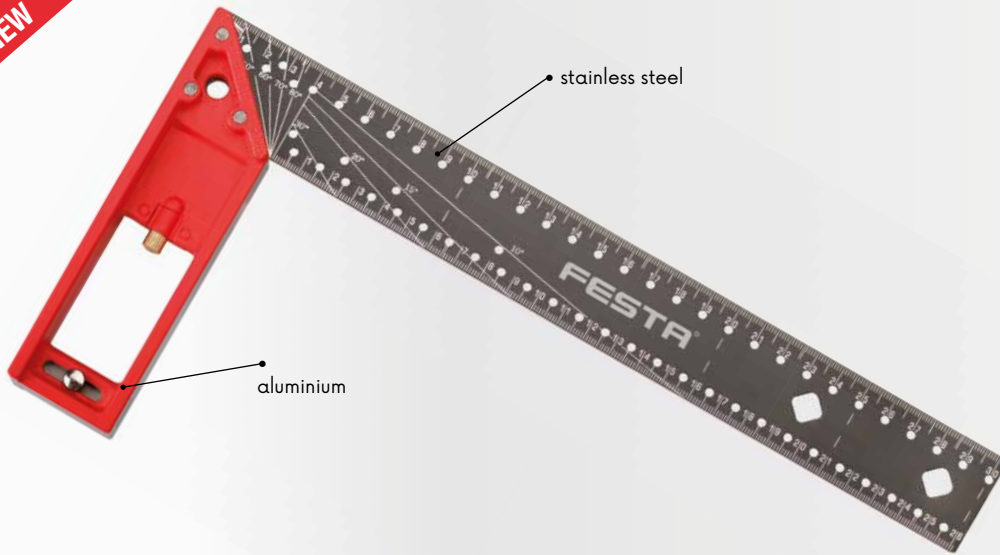

stainless steel

aluminium

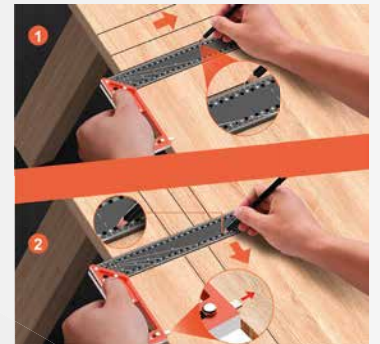

FESTA

UHOLNÍK TRUHLÁRSKY MULTIFUNKČNÝ

INOX ALU

No.	Specification	
14415	300 mm	6
14417	400 mm	6



FESTA

UHOLNÍK TRUHLÁRSKY



Č.p.	špecifikácia	
14220	200 x 125 mm	10
14225	250 x 135 mm	10
14230	300 x 135 mm	10



FESTA

UHOLNÍK TESÁRSKY



Č.p.	špecifikácia	
14350	500 x 235 mm	10
14360	600 x 300 mm	10
14370	700 x 300 mm	10

Č.p.	špecifikácia	
14380	800 x 320 mm	10
14399	1000 x 360 mm	10



FESTA
UHOLNÍK

ALU



Č.p.	špecifikácia	
14450	190 x 355 mm	6
14451	200 x 405 mm	6



FESTA
UHOLNÍK MURÁRSKY

ALU

Č.p.	špecifikácia	
14445	600 x 600 mm	1
14446	1200 x 1200 mm	1



UHOLNÍK

Č.p.	špecifikácia	
14410	300 x 200 mm	50
14411	600 x 400 mm	36



UHOLNÍK MURÁRSKY

Č.p.	špecifikácia	
14455	300 x 200 mm	50
14456	500 x 250 mm	50
14457	700 x 300 mm	40
14458	1000 x 450 mm	30



UHOLNÍK PLOCHÝ

Zn

Č.p.	špecifikácia	
14471	150 x 100 mm	25
14472	250 x 125 mm	25
14473	400 x 200 mm	30
14474	600 x 300 mm	25



UHOLNÍK PRÍLOŽNÝ

Zn

Č.p.	špecifikácia	
14490	100 x 50 mm	10
14491	150 x 75 mm	10
14492	250 x 125 mm	10
14493	400 x 200 mm	10
14494	600 x 300 mm	10



UHOLNÍK STOLÁRSKY

ALU

HOBBY

Č.p.	špecifikácia	
14425	250 x 130 mm	12
14430	300 x 130 mm	12
14435	350 x 156 mm	12
14440	400 x 156 mm	12

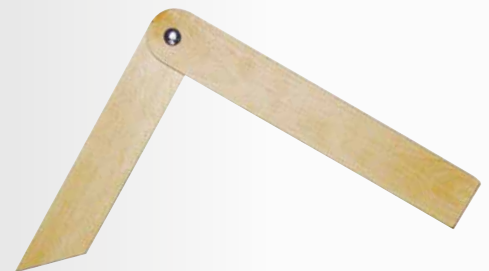

POKOSNÍK DREVENÝ



Č.p.	špecifikácia	
14025	255 x 285 mm	1

HORIZONT[®] EXACTA

Vodováhy s najvyššou presnosťou

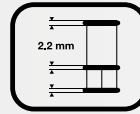
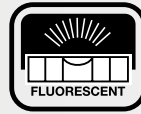
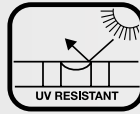
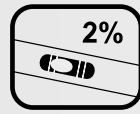
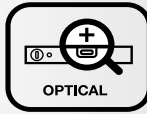
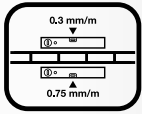

Každý kus je elektronicky testovaný a má svoje registračné číslo, výrobca je držiteľom osvedčenia ISO 9001



HORIZONT[®]

VODOVÁHA EXACTA, 2 LIBELY

ALU



Č.p.	špecifikácia
15033	60 cm

10



HORIZONT[®]

VODOVÁHA EXACTA, 3 LIBELY

ALU



Č.p.	špecifikácia
15034	80 cm
15035	100 cm

10

10



HORIZONT[®]

VODOVÁHA EXACTA, 3 LIBELY, S MADLAMI

ALU



Č.p.	špecifikácia
15036	120 cm
15037	150 cm
15039	200 cm

10

10

10

HORIZONTAL[®]

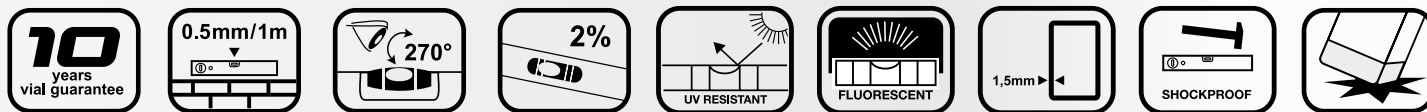

Každý kus je elektronicky testovaný a má svoje registračné číslo, výrobca je držiteľom osvedčenia ISO 9001



HORIZONTAL[®] VODOVÁHA, 2 LIBELY



Č.p.	špecifikácia	
15003	30 cm	30
15004	40 cm	30
15005	50 cm	30
15006	60 cm	30
15008	80 cm	30
15010	100 cm	30
15012	120 cm	10
15015	150 cm	10
15018	180 cm	10
15020	200 cm	10



HORIZONTAL[®] VODOVÁHA, 3 LIBELY



Č.p.	špecifikácia	
15103	30 cm	30
15104	40 cm	30
15105	50 cm	30
15106	60 cm	30
15108	80 cm	30
15110	100 cm	30
15112	120 cm	10
15115	150 cm	10
15118	180 cm	10
15120	200 cm	10

**HORIZONT.**

VODOVÁHA, 2 LIBELY + MAGNET

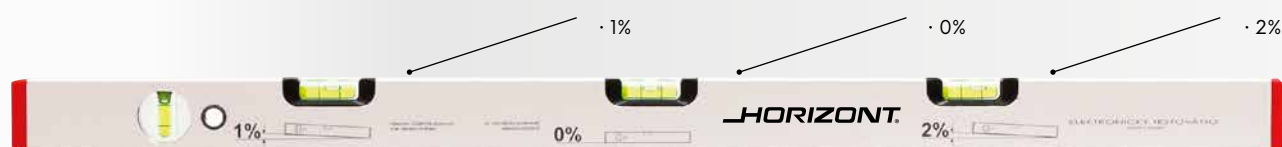

Č.p.	špecifikácia	
15204	40 cm	30
15205	50 cm	30
15206	60 cm	30
15208	80 cm	30
15210	100 cm	30
15212	120 cm	10
15215	150 cm	10
15218	180 cm	10
15220	200 cm	10

**HORIZONT.**

VODOVÁHA S MOŽNOSŤOU MERANIA SKLONU, 4 LIBELY

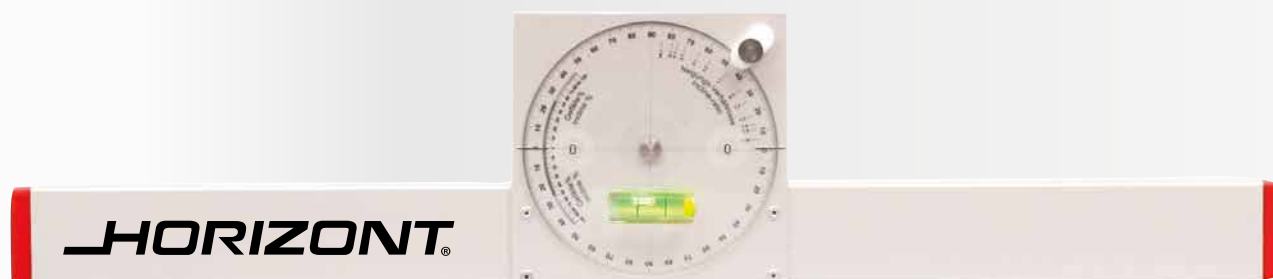

Č.p.	špecifikácia	
15230	80 cm	10

**HORIZONT.**

VODOVÁHA S MOŽNOSŤOU MERANIA SKLONU, 1 LIBELA



Č.p.	špecifikácia	
15235	60 cm	1

**HORIZONT.**

LATA SŤAHOVACIA - BEZ LIBIEL



Č.p.	špecifikácia	
15310	100 cm	10
15315	150 cm	10
15318	180 cm	10
15320	200 cm	10
15325	250 cm	10
15330	300 cm	10
15335	350 cm	10
15340	400 cm	10



HORIZONT.

HORIZONT.

LATA ŠTAHOVACIA - 1 LIBELA

ALU

Č.p.	špecifikácia	
15415	150 cm	10
15418	180 cm	10
15420	200 cm	10
15425	250 cm	10
15430	300 cm	10



HORIZONT.

HORIZONT.

LATA ŠTAHOVACIA - 2 LIBELY

ALU

Č.p.	špecifikácia	
15510	100 cm	10
15515	150 cm	10
15518	180 cm	10
15520	200 cm	10
15525	250 cm	10
15530	300 cm	10
15535	350 cm	10
15540	400 cm	5



HORIZONT.

HORIZONT.

LATA ŠTAHOVACIA - S MADLAMI, BEZ LIBIEL

ALU

Č.p.	špecifikácia	
15615	150 cm	10
15620	200 cm	10
15625	250 cm	10
15630	300 cm	10



HORIZONT.

HORIZONT.

LATA ŠTAHOVACIA - S MADLAMI, 2 LIBELY

ALU

Č.p.	špecifikácia	
15710	100 cm	10
15715	150 cm	10
15720	200 cm	10
15725	250 cm	10
15730	300 cm	10
15735	350 cm	10
15740	400 cm	5

NEW

HORIZONT. UHOLNÍK MURÁRSKY

ALU



Č.p.	špecifikácia	
14485	800 x 1200 mm	1
14486	1000 x 1500 mm	1



HORIZONT. LATA ŠTAHOVACIA - TRAPÉZOVÝ PROFIL

PROFIL TRAPÉZOVÝ

- trapézový profil slúži na jemnejšie úpravy povrchu
- vhodné pre štukatérov a fasádnikov
- vhodné pre tenkovrstvé omietky

ALU

Č.p.	špecifikácia	
15810	100 cm	10
15812	120 cm	10
15815	150 cm	10
15818	180 cm	10
15820	200 cm	10
15825	250 cm	10
15830	300 cm	10



HORIZONT. LATA ŠTAHOVACIA - H PROFIL

PROFIL "h"

- "h" profil slúži na jemnejšie úpravy povrchu
- vhodné pre štukatérov a fasádnikov
- vhodné na štukovanie stropných omietok

ALU

Č.p.	špecifikácia	
15850	100 cm	10
15853	150 cm	10
15855	180 cm	10
15860	200 cm	10
15870	250 cm	10
15880	300 cm	10



HORIZONT. STOJAN NA VODOVÁHY HORIZONT

· osadenie stojana 15998

15003	· 5 ks
15004	· 5 ks
15005	· 5 ks
15006	· 5 ks
15008	· 5 ks
15010	· 5 ks
15012	· 5 ks
15015	· 3 ks
15018	· 3 ks
15020	· 3 ks
15108	· 3 ks
15206	· 3 ks
15210	· 3 ks

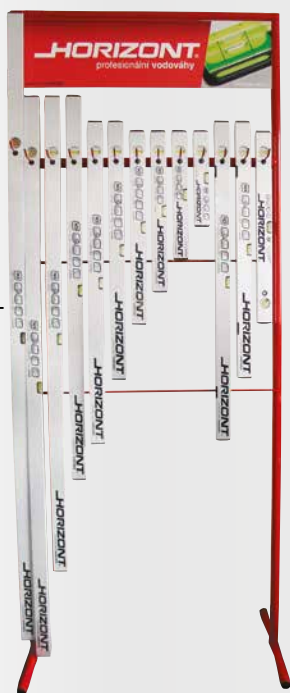

HORIZONT. STOJAN NA VODOVÁHY A LATY HORIZONT

· osadenie stojana 15996

15004	· 5 ks
15005	· 5 ks
15006	· 5 ks
15008	· 5 ks
15010	· 5 ks
15012	· 5 ks
15015	· 5 ks
15018	· 5 ks
15020	· 5 ks
15315	· 2 ks
15320	· 2 ks
15325	· 3 ks
15515	· 2 ks
15520	· 2 ks
15525	· 3 ks



Č.p.	špecifikácia	
15999	85 x 210 x 50 cm	1
15998	85 x 210 x 50 cm osadený	1

Č.p.	špecifikácia	
15997	55 x 75 x 40 cm	1
15996	55 x 75 x 40 cm osadený	1

- Presnosť 0,5 mm / 1 m (v základnej polohe)
- UV stabilná tekutina libely
- Nárazuvzdorné gumové koncovky
- Hrúbka profilu základne 2,4 mm



NIVELA

VODOVÁHA NIVELA - 2 LIBELY

• gumové koncovky



Č.p.	špecifikácia	
15904	40 cm	30
15906	60 cm	30
15908	80 cm	30
15910	100 cm	30
15912	120 cm	20
15915	150 cm	10
15920	200 cm	20



VODOVÁHA - 3 LIBELY

ALU **HOBBY**

Č.p.	špecifikácia	
15954	40 cm	60
15956	60 cm	60
15958	80 cm	60
15960	100 cm	30
15962	120 cm	30
15965	150 cm	30
15970	200 cm	30



VODOVÁHA DIGITÁLNA

- presnosť 0,5 mm | m
- rozlíšenie 0,1°
- funkcia HOLD na uchovávanie nameraných hodnôt
- hrúbka profilu 1,8 mm



Č.p.	špecifikácia	
26215	600 mm	1



VODOVÁHA NA POVRÁZOK



Č.p.	špecifikácia	
15981		1



Č.p.	špecifikácia	
15980	230 mm	1

VODOVÁHA S MAGNETOM, 3 LIBELY



VODOVÁHA STĽPOVÁ

- 3 libely, magnety, fixačná páska



Č.p.	špecifikácia	
26028		12



VODOVÁHA HADICOVÁ



Č.p.	špecifikácia	
15992	Sklenené rúrky - hadica 10 m	1
15993	Sklenené rúrky - hadica 15 m	1
15990	Sklenené rúrky	50
15991	Plastové rúrky	50

FESTA

SKLONOMER DIGITÁLNY

- 0° - 360°
- presnosť ±0,1°
- rozlíšenie 0,1°
- funkcia automatického vypnutia
- funkcia HOLD na uchovávanie nameraných hodnôt
- podsvietený display
- rozmer 60x60x25 mm
- batéria 1xAAA



· puzdro

· magnetická spodná strana



Č.p. špecifikácia

26218

1

FESTA

DIGITÁLNY UHLOMER

- LCD display
- rozsah merania 0° - 360°
- rozlíšenie 0,1°
- presnosť ± 0,3



Č.p. špecifikácia

26217 200 mm

1

FESTA

VODOVÁHA S DIGITÁLNYM UHLOMEROM

- LCD display
- rozsah merania 0° - 225°
- rozlíšenie 0,1°
- presnosť ± 0,3



Č.p. špecifikácia

26216 300 mm

1

NEW

**FESTA****LASER ALL LINE ZELENÝ 3 X 360 °**

- 1x horizontálna rovina + 2x vertikálna rovina (zelený lúč)
- samonivelačný rozsah $\pm 4^\circ$
- presnosť: 0,2 mm/m
- vo vnútorných priestoroch 30 m, s laserovým prijímačom až 50 m
- pulzný režim – odporúčané príslušenstvo prijímač 26209
- dodávané s: prepravný kufor, 4 x AA alkalické batérie, laserový terč, okuliare, Li-ion batéria 2600 mAh, profesionálny držiak, nabíjačka, držiak Li-ion batéria



No.	Specification
26204	green



1

NEW

**FESTA****LASER ZELENÝ KRÍŽOVÝ**

- 1x horizontálna rovina + 1x vertikálna rovina (zelený lúč) |
- samonivelačný rozsah $\pm 3^\circ$
- presnosť: 0,2 mm/m
- vo vnútorných priestoroch 20 m, s laserovým prijímačom až 50 m
- pulzný režim – odporúčané príslušenstvo prijímač 26209
- dodávané s: prepravné puzdro, 2 x AA alkalické batérie, držiak



No.	Specification
26201	green



1

NEW

**FESTA****LASEROVÝ PRIJÍMAČ**

- pre lasery s pulzným režimom na predĺženie dosahu až 50 m
- dodávané s: 9 V batéria, držiak
- pre 26201, 26204



No.	Specification
26209	range: 50 m



1

NEW

Laser

**FESTA****DIALKOMER**

- rozsah merania 0,05 - 50 m
- presnosť merania ± 2 mm, jednotka merania mm/in/ft
- kontinuálne meranie, meranie plochy, meranie objemu, výpočet dĺžky tretej strany podľa pytagorovej vety, LCD FSTN, sčítanie/odčítanie, max./min. meranie
- maximálne úložisko na 100 hodnôt, štvorradový displej LCD FSTNS s podsvietením,
- vlnová dĺžka lasera 630 - 670 nm, pracovná teplota 0 - 40°C
- rozmery 112 x 50 x 25 mm, hmotnosť 90 g
- dodávané s: prepravné púzdro, 2xAAA alkalické batérie



No.	Specification
26211	



1

Laserliner®**LUXTEST-MASTER**

Profesionálny merací prístroj intenzity osvetlenia

- Meranie intenzity osvetlenia na pracoviskách, kanceláriách, vo verejných budovách a v priemysle
- Citlivé fotodiódy s Kosinovou korekciou pre širokouhlé meranie svetla
- Relatívna funkcie merania pre referenčné meranie a porovnávanie
- Špičková funkcia pre registráciu rýchle zmeny v úrovni osvetlenia
- Funkcia automatického zapamätania hodnoty
- Automatické a manuálne prepínanie rozsahu
- Funkcia nulovania
- Meranie premenné: Lux (lm | m²), nožné sviečky (lm | ft²)
- Min. | max. displej
- 1 | 4 „závit pre umiestnenie na statív

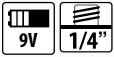

Č. p. špecifikácia

Rozsah merania: 20 Lux ... 200000 Lux

26520 presnosť: ± 3% (referenčná hodnota 2854 K)

Kosínus uhlová odchýlka: ± 2% (30°), ± 6% (60°)

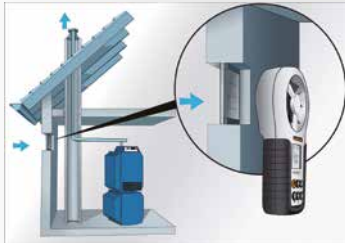
**Laserliner®****AIRFLOWTEST-MASTER**

Profesionálny anemometer na meranie prietoku vzduchu, objemového prietoku a rýchlosti vetra

- Integrovaný senzor na meranie okolitej teploty, relatívnej vlhkosti a rosného bodu
- USB rozhranie pre ukladanie nameraných dát
- PC softvér
- Veľké obežné koleso: 65 mm.
- Min. | Max. displej.
- 1 | 4 „závit pre pripojenie na statív pri dlhodobom meraní
- Osvetlený, prehľadný displej s trvale viditeľnými hodnotami okolitej teploty a relatívnej vlhkosti



Č. p. špecifikácia

prietok: 0.80...30 m | s | ± 2%

Teplota okolitého prostredia: -10...60°C | ± 1.5°C

26521 Relatívna vlhkosť vzduchu: 20%...80% | ± 3%

Prúd vzduchu: 0...99990 CMM



NAHRÁVANIE DÁT NA PC

špecifikácia

Dodávané s: PC softvér, USB kábel, batérie, prepravný kufor



1

špecifikácia

Dodávané s: batérie, prepravný kufor



1

Laserliner®**CONDENSESPOT PLUS**

Infračervený teplomer tepelných mostov a kondenzácie

- 8-bodový laserový kruh merací presne potrebnú oblasť
- Lokalizácia kondenzácie v režime tepelného mosta a rosného bodu
- Rozsah merania -40 ° C ... 365 ° C
- Emisný pomer 0,01-1,0
- Funkcia farebného upozornenia pomocou farieb na displeji
- Rýchly výber 5 predvolených hodnôt emisíí
- Stĺpcový graf ako ukazovateľ pre kondenzáciu vody
- Šošovka 12: 1, prehľadný podsvietený displej.

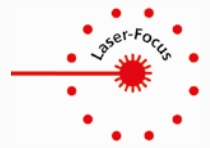

1



2xAA

Č.p.	špecifikácia	
	Rozsah merania infračerveným lúčom:	-40°C ... 365°C
	presnosť:	± -40°C ... 0°C (± 1°C + 0,1°C 1°C) 0°C ... 30°C (± 1°C or ± 1%, záleží na vyššej hodnote) >30°C (± 2°C or ± 2%, záleží na vyššej hodnote)
26528	Teplota okolia: presnosť:	-20°C...65°C ± 1°C (0°C...50°C) ± 2,5°C (<0°C and >50°C)
	Vlhkosť vzduchu (relatívna): presnosť:	1%...99% ± 3% (20%...80%) ± 5% (<20% and >80%)
	Dodávané s:	batérie

**Laserliner®****COMPACTCROSS - LASER PLUS**

Automatický krížový laser na vyrovnávanie dlaždíc, hrazdeného muriva, okien, dverí atď.

- Doplnkový režim sklonu umožňuje osadzovať tiež plochy so spádom
- RX-Ready: integrovaný režim ručného prijímača
- Rozhranie Bluetooth®* pre diaľkové ovládanie prístroja
- Rozsah samočinnej nivelácie 4 °, Presnosť 0,35 mm | m



2xAA



Č.p. špecifikácia

26037

Dodávané s:

batérie



1



FESTA

ZNAČKOVAC HĽBKOVÝ HB



Č.p.	špecifikácia	
13262	150 mm	20



FESTA

CERUZKA S VYMENITEĽNOU TUHOU HB



Č.p.	špecifikácia	
13279	ceruzka + náhradná tuha HB	24
13284	náhradné tuhy 5 ks	20

NEW



FESTA

FAREBNÉ TUHY DO HĽBKOVÉHO ZNAČKOVÁČA pre 13262



Č.p.	špecifikácia	
13267	2x žltá 2x červená 2x modrá	1



FESTA

ČIERNE TUHY HB DO HĽBKOVÉHO ZNAČKOVÁČA pre 13262



Č.p.	špecifikácia	
13263	6x čierna	20



FESTA

CERUZKA TESÁRSKA HB



Č.p.	špecifikácia	MOQ
13270	HB · 180 mm	12
13271	HB · 180 mm · súprava 3 ks	32
13265	HB · 250 mm	96



FESTA

CERUZKA TESÁRSKA HB



Č.p.	špecifikácia	MOQ
13269	HB · 180 mm	50
13266	HB · 250 mm	50



FESTA
CERUZKA TESÁRSKA HB



MOQ
12

Č.p.	špecifikácia	MOQ
13272	HB · 250 mm	96
13264	HB · 250 mm · bez potlača	96



FESTA
CERUZKA TESÁRSKA HB



MOQ
50

Č.p.	špecifikácia	MOQ
13268	250 mm	50



FESTA
CERUZKA TROJHRANNÁ HB



MOQ
12

Č.p.	špecifikácia	MOQ
13278	250 mm	96



FESTA
CERUZKA TESÁRSKA HB



MOQ
12

Č.p.	špecifikácia	MOQ
13280	180 mm	96



FESTA
CERUZKA 6H



MOQ
12

Č.p.	špecifikácia	MOQ
13275	6H · 250 mm	96



FESTA
CERUZKA NA SKLO A KERAMIKU



MOQ
12

Č.p.	špecifikácia	MOQ
13273	175 mm červená tuha - sklo, keramika	144

**FESTA**

CERUZKA S FAREBNOU TUHOU

MOQ
12

Č.p.	špecifikácia
13274	175 mm, červeno - modrá



96



CERUZKA S ČERVENOU TUHOU

MOQ
12

Č.p.	špecifikácia
13276	175 mm



144



· šmirgel

OREZÁVATKO NA CERUZKY

Č.p.
13261



12



ZNAČKOVAČ PERMANENTNÝ



- extra silný hrot
- pre značenie aj na mastných a vlhkých povrchoch



MOQ
12

Č.p.	špecifikácia	
13216	červený	12
13217	čierny	12
13218	modrý	12
13219	zelený	12



ZNAČKOVAČ PERMANENTNÝ



- 2 typy hrotu značkovača
- pre značenie aj na mastných a vlhkých povrchoch



Č.p.	špecifikácia		
13227	biely	ALU púzdro	40
13222	biely	PVC púzdro	12
13228	červený	ALU púzdro	40
13229	čierny	ALU púzdro	40
13230	modrý	ALU púzdro	12
13231	zelený	ALU púzdro	12



ZNAČKOVAČ PERMANENTNÝ



MOQ
12



Č.p.	špecifikácia	
13214	biely	12
13225	červený	12
13226	čierny	12
13223	modrý	12
13224	zelený	12



ZNAČKOVAČ PERMANENTNÝ



MOQ
12



Č.p.	špecifikácia	
13235	červený	12
13236	čierny	12
13237	modrý	12
13238	zelený	12



NEW



NEW



ZNAČKOVAČ PERMANENTNÝ, OBOJSTRANNÝ

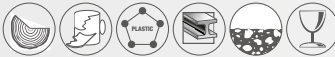

MOQ 12



Č.p. I No. 13206 Špecifikácia ○ biely

12



FESTA

ZNAČKOVAČ HLOUBKOVÝ, PERMANENTNÝ



Č.p. I No. 13246 Špecifikácia ● čierny

10

NEW

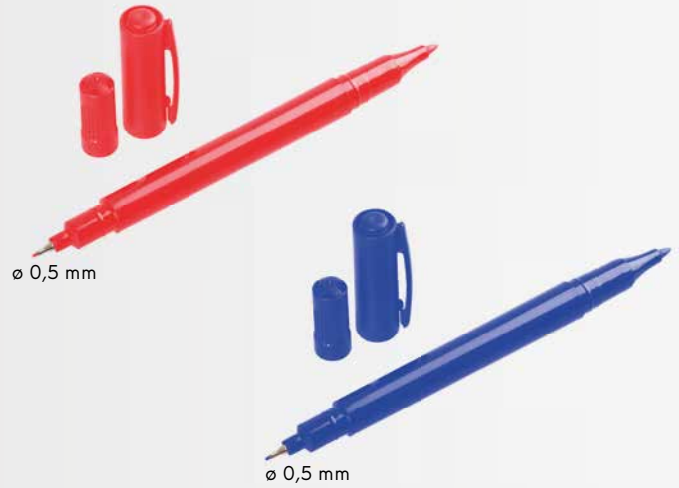

ZNAČKOVAČ PERMANENTNÝ, OBOJSTRANNÝ



MOQ 12



Č.p. I No. 13207 13208 Špecifikácia ● červený ● modrý

12 12



ZNAČKOVAČ PERMANENTNÝ MINI



· dĺžka fixy 9 cm



MOQ 72



Č.p. 13205 Špecifikácia ● ● ● ●

72



ZNAČKOVAČ PERMANENTNÝ, OBOJSTRANNÝ

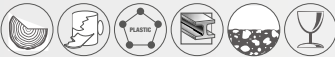

MOQ 12



Č.p. 13212 Špecifikácia ● čierny

12



FESTA

IHLA RYSOVACIA



Č.p.	špecifikácia	
13281	150 mm	50



KRUŽIDLO RYSOVACIE



Č.p.	špecifikácia	
13285	200 mm	10



FESTA

IHLA RYSOVACIA



Č.p.	špecifikácia	
13282	200 mm	50



KRIEDA BIELA

12x



Č.p.	špecifikácia	
13260	12 x 12 x 80 mm	46



FESTA

ZNAČKOVAČ UNIVERZÁLNY SÚPRAVA 5 KS

· Ø 13 x 110 mm

5x



Č.p.	špecifikácia		Č.p.	špecifikácia	
13240	5 barev	20	13243	žltá	20
13241	červená	20	13244	zelená	20
13242	čierna	20	13245	biela	20



CERUZKY VOSKOVÉ SÚPRAVA 6 KS

6x



Č.p.	špecifikácia	
13277	● ● ○ ● ● ●	88

SPREJ FLUORESCENČNÝ TRACKMARKER 500ML

- vysoká viditeľnosť - fluorescenčný pigment
- bezpečnostné viečko
- rýchloschnúci 10 min.
- trvanlivosť 3 mesiace
- použitie - betón, asfalt, tráva, štrk, piesok, kameň, drevo

MADE IN EU



Č.p.	špecifikácia	
13250	● žltý	12
13251	● červený	12
13252	● oranžový	12
13253	● zelený	12
13254	● ružový	12
13249	● modrý	12



SPREJ FLUORESCENČNÝ MARK 6M FLUO 500 ML

- vysoká viditeľnosť - fluorescenčný pigment
- bezpečnostné viečko
- rýchloschnúci 10 min.
- trvanlivosť 6 mesiacov
- použitie - betón, asfalt, tráva, štrk, piesok, kameň, drevo, sklo

MADE IN EU



Č.p.	špecifikácia	
13360	● žltý	12
13361	● červený	12
13362	● oranžový	12
13363	● zelený	12
13364	● ružový	12
13365	○ biely	12



SPREJ FLUORESCENČNÝ FLUO 500 ML

- vysoká viditeľnosť - fluorescenčný pigment
- bezpečnostné viečko
- rýchloschnúci 10 min.
- trvanlivosť 12 mesiacov
- použitie - betón, asfalt, tráva, štrk, piesok, kameň, drevo, sklo

MADE IN EU



Č.p.	špecifikácia	
13350	● žltý	12
13351	● červený	12
13352	● oranžový	12
13353	● zelený	12
13354	● ružový	12
13355	○ biely	12



SPREJ FLUORESCENČNÝ IDEAL 500 ML

- vysoká viditeľnosť - fluorescenčný pigment
- bezpečnostné viečko
- rýchloschnúci 10 min.
- trvanlivosť 12 mesiacov
- použitie - betón, asfalt, tráva, štrk, piesok, kameň, drevo



Č. p.	špecifikácia	
13255	● žltý	12
13256	● červený	12
13257	● oranžový	12
13258	● zelený	12
13259	● ružový	12



DRŽIAK NA SPREJ SOPPEC

- Pre rozprašovače Trackmarker a Fluó



Č. p.	špecifikácia	
13296		1

DRŽIAK NA NA SPREJ SOPPEC

- Pre rozprašovače Trackmarker a Fluó



Č. p.	špecifikácia	
13295		1



60

KLIESTE



66

SIKO KLIESTE, HASÁKY



68

KLIESTE PÁKOVÉ



70

NOŽNICE NA PLECH,
NOŽNICE TECHNICKÉ

73

GOLA SADY A RAČNE



82

HLAVICE, NADSTAVCE,
ADAPTÉRY

87

KLÚČE



93

SKRUTKOVAČE



101

BITY



110

INBUSY, SADY



115

KLADIVÁ, PALICE

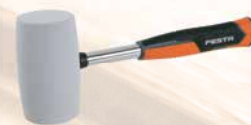

120

GUMOVÉ ŠŮLKY



122

SEKERY



125

PÁČIDLÁ



126

SEKÁČE, DLÁTA

DIELENSKÉ NÁRADIE

58 - 159



129

SPONKOVAČKY



131

SVORKY A ZVERÁKY



134

PRACOVNÉ STOLY



136

KLIESTE NITOVACIE



140

ZVÁRANIE

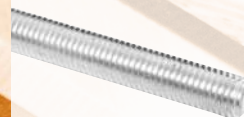

143

ZÁVITOVÉ TYČE,
PODLOŽKY, MATICE

144

KOMPRESORY, STRIEKACIE
A OFUKOVACIE PIŠTOLE

149

OCHRANNÉ POMÔCKY



155

NÁRAĐOVÉ PÁSY,
BRAŠNE A PÚZDRA

FESTA®



ERGONOMIC handle



FESTA

KLIEŠTE KOMBINOVANÉ



Č.p.	špecifikácia	
17101	160 mm	6
17102	180 mm	6
17103	200 mm	6



FESTA

KLIEŠTE BOČNÉ ŠTIEPACIE



Č.p.	špecifikácia	
17148	180 mm	6



FESTA

KLIEŠTE BOČNÉ ŠTIEPACIE



Č.p.	špecifikácia	
17104	160 mm	6
17105	180 mm	6



FESTA

KLIEŠTE RÁDIOVÉ



Č.p.	špecifikácia	
17140	160 mm	6
17142	200 mm	6

FESTA

KLIEŠTE RÁDIOVÉ ZAHNUTÉ



Č.p.	špecifikácia	
17145	160 mm	6
17146	200 mm	6

**FESTA**

KLIŠTE KOMBINOVANÉ

Č.p.	špecifikácia	
DIN 5746	TUV GS HRC 50-55 ERGO HANDLE	
17001	160 mm	6
17002	180 mm	6
17003	200 mm	6

**FESTA**

KLIŠTE BOČNÉ ŠTIEPACIE

Č.p.	špecifikácia	
DIN 5749	TUV GS HRC 50-55 ERGO HANDLE	
17004	160 mm	6
17005	180 mm	6

**FESTA**KLIŠTE BOČNÉ ŠTIEPACIE
HEAVY DUTY

Č.p.	špecifikácia	
DIN 5749	TUV GS HRC 50-55 ERGO HANDLE	
17108	180 mm	6

**FESTA**

KLIŠTE ŠTIEPACIE ČELNÉ

Č.p.	špecifikácia	
DIN 5749	TUV GS HRC 50-55 ERGO HANDLE	
17110	160 mm	6

**FESTA**

KLIŠTE RÁDIOVÉ

Č.p.	špecifikácia	
DIN 5745	TUV GS HRC 50-55 ERGO HANDLE	
17006	160 mm	6
17011	200 mm	6

**FESTA**

KLIŠTE RÁDIOVÉ ZAHNUTÉ

Č.p.	špecifikácia	
DIN 5745	TUV GS HRC 50-55 ERGO HANDLE	
17007	160 mm	6
17008	200 mm	6

**FESTA**

KLIŠTE PLOCHÉ

Č.p.	špecifikácia	
DIN 5746	TUV GS HRC 50-55 ERGO HANDLE	
17009	160 mm	6

**FESTA**

KLIŠTE OČKOVÉ

Č.p.	špecifikácia	
DIN 5745	TUV GS HRC 50-55 ERGO HANDLE	
17010	160 mm	6

**FESTA**

KLIŠTE ODIZOLOVÁVACIE

Č.p.	špecifikácia	
DIN 5744	TUV GS HRC 50-55 ERGO HANDLE	
17024	160 mm	6



KLIŠTE KOMBINOVANÉ

Č.p.	špecifikácia	
DIN 5746	TUV GS	
17094	160 mm	6
17095	180 mm	6
17096	200 mm	6



KLIŠTE BOČNÉ ŠTIEPACIE

Č.p.	špecifikácia	
DIN 5749	TUV GS	
17097	160 mm	6
17098	180 mm	6



KLIŠTE RÁDIOVÉ

Č.p.	špecifikácia	
DIN 5745	TUV GS	
17099	160 mm	6
17100	200 mm	6



FESTA

VDE KLIŠTE KOMBINOVANÉ

△ 1000 V IEC/EN60900:2004

DIN 5746

CrV

HRC 58-62



Č.p.	špecifikácia	
17125	160 mm	6
17126	180 mm	6
17127	200 mm	6



FESTA

VDE KLIŠTE BOČNÉ ŠTIEPACIE

△ 1000 V IEC/EN60900:2004

DIN 5749

CrV

HRC 58-62



Č.p.	špecifikácia	
17128	160 mm	6



FESTA

VDE KLIŠTE KÁBLOVÉ ŠTIEPACIE

△ 1000 V IEC/EN60900:2004

CrV

HRC 58-62



Č.p.	špecifikácia	
17130	160 mm	6



FESTA

VDE KLIŠTE RÁDIOVÉ

△ 1000 V IEC/EN60900:2004

DIN 5745

CrV

HRC 58-62



Č.p.	špecifikácia	
17133	160 mm	6



FESTA

VDE KLIŠTE RÁDIOVÉ ZAHNUTÉ

△ 1000 V IEC/EN60900:2004

DIN 5745

CrV

HRC 58-62



Č.p.	špecifikácia	
17135	160 mm	6



FESTA

VDE KLIŠTE OČKOVÉ

△ 1000 V IEC/EN60900:2004

DIN 5745

CrV

HRC 58-62



Č.p.	špecifikácia	
17137	160 mm	6



FESTA

VDE KLIŠTE ODIZOLOVÁVACIE

△ 1000 V IEC/EN60900:2004

CrV

DIN 5744



Č.p.	špecifikácia	
17138	160 mm	6



KLIŠTE ODIZOLOVÁVACIE

Č.p.	špecifikácia	
17180	Ø 0,75 - 2,5 mm	12



KLIŠTE ODIZOLOVÁVACIE

Č.p.	špecifikácia	
17181	Ø 0,60 - 2,6 mm	10

NEW

FESTA

ODIZOLOVÁVAČ KÁBLOV

AWG	mm ²
10	6,0
12	4,0
14	2,5
16	1,5
18	1,0
20	0,5

- koaxiálny kábel RG6/59
- nízkonapäťový kábel Ø 8 - 13 mm

Č.p.	špecifikácia	
16202	125 mm	10



10

NEW



FESTA®

KLIESTE ŠTIEPACIE NA JEMNÉ KÁBLE

· max Ø 0,2 - 2,1 mm

CrV

Č.p.	špecifikácia
17047	140 mm

10



FESTA®

KLIESTE KOMBINOVANÉ MINI

Č.p.	špecifikácia
17041	110 mm

12



FESTA®

KLIESTE BOČNÉ ŠTIEPACIE MINI

Č.p.	špecifikácia
17042	110 mm

12



FESTA®

KLIESTE ŠTIEPACIE ČELNÉ MINI

Č.p.	špecifikácia
17043	100 mm

12



FESTA®

KLIESTE RÁDIOVÉ MINI

Č.p.	špecifikácia
17044	120 mm

12



FESTA®

KLIESTE OČKOVÉ MINI

Č.p.	špecifikácia
17045	120 mm

12



FESTA®

KLIESTE MINI SÚPRAVA

4x

Č.p.	špecifikácia
17040	

6



FESTA®

KLIESTE SEGEROVÉ

Č.p.	špecifikácia
17190	180 mm vnútorné
17191	180 mm vonkajšie

6



FESTA®

KLIESTE SEGEROVÉ

Č.p.	špecifikácia
17192	180 mm vnútorné
17193	180 mm vonkajšie

15



KLIESTE SEGEROVÉ

Č.p.	špecifikácia
17025	súprava

10



FESTA

KLIEŠTE MULTIFUNKČNÉ

- 9 funkcií
- púzdro

CrV

Č.p. špecifikácia
16232



12



FESTA

KLIEŠTE MULTIFUNKČNÉ

- pre montáž oplatenia

CrV

Č.p. špecifikácia
17109 270 mm



4



KLIEŠTE RÝCHLOUPÍNACIE

Č.p. špecifikácia
17034 220 mm



5



KLIEŠTE RÝCHLOUPÍNACIE

Č.p. špecifikácia
17036 260 mm



5



KLIEŠTE RÝCHLOUPÍNACIE

Č.p. špecifikácia
17035 220 mm



10



KLIEŠTE RÝCHLOUPÍNACIE

Č.p. špecifikácia
17023 220 mm



6



FESTA

KLIŠTE SIKO S TLAČIDLOM

CrV

Č.p.	špecifikácia	rozsah čelustí	
17059	180 mm	0 - 30 mm	6
17061	250 mm	0 - 30 mm	6
17062	300 mm	0 - 40 mm	6
17080	400 mm	0 - 84 mm	4



FESTA

KLIŠTE SIKO S TLAČIDLOM

CrV

Č.p.	špecifikácia	rozsah čelustí	
17084	250 mm	0 - 30 mm	6



FESTA

KLIŠTE SIKO

CrV

· veľký rozsah čelustí

Č.p.	špecifikácia	rozsah čelustí	
17086	250 mm	0 - 50 mm	6



FESTA

KLIŠTE SIKO

CrV

Č.p.	špecifikácia	rozsah čelustí	
17081	180 mm	0 - 30 mm	6
17014	250 mm	0 - 30 mm	6
17082	300 mm	0 - 50 mm	6



FESTA

KLIŠTE SIKO AUTOMATICKY NASTAVITEĽNÉ

CrV

Č.p.	špecifikácia	rozsah čelustí	
17079	250 mm	0 - 50 mm	6



FESTA

KLIŠTE SIKO

CrV

Č.p.	špecifikácia	rozsah čelustí	
17012	250 mm	0 - 40 mm	6
17060	300 mm	0 - 50 mm	10



KLIŠTE SIKO

Č.p.	špecifikácia	rozsah čelustí	
17013	250 mm	0 - 30 mm	6
17033	300 mm	0 - 50 mm	6



ČELUŠTE PLASTOVÉ PRE KLIŠTE SIKO

· vhodné pre 17061, 17079, 17086

Č.p.	špecifikácia	
17085	1 pár	1



FESTA

HASÁK 45°, S

CrV



Č.p.	špecifikácia	
17067	1" 330 mm	1
17068	1,5" 420 mm	1
17069	2" 540 mm	1



FESTA

HASÁK 90°

CrV



Č.p.	špecifikácia	
17075	1" 330 mm	1
17076	1,5" 420 mm	1
17077	2" 540 mm	1



FESTA

HASÁK 90°

CrV



Č.p.	špecifikácia	
17070	2,5" 355 mm	12
17071	3" 455 mm	8
17072	3,5" 610 mm	10



FESTA

HASÁK S NASTAVOVACOU SKRUTKOU

CrV

Č.p.	špecifikácia	
17063	230 mm	6
17064	300 mm	6



HASÁK S VODIACOU MATICOU

Č.p.	špecifikácia	
17065	260 mm	36
17066	300 mm	36

FESTA

KLIESTE NA LANKÁ

- oceľové drôty
- ACSR káble
- letecké káble

CrV

max. Ø
12 mm



Č.p.	špecifikácia	8
17039	24' 610 mm	



FESTA

KLIESTE NA LANKÁ

- oceľové drôty
- ACSR káble
- letecké káble

CrV

max. Ø
6 mm



Č.p.	špecifikácia	6
17029	200 mm	



FESTA

PÁKOVÉ ŠTIEPACIE KLIESTE PROFESIONÁLNE

- ťelúste na káble a lanká

Cr-Mo

HRC 58-62



Č.p.	špecifikácia	max. Ø drátu	max. Ø lanka	max. Ø kabelu	1
17055	14' 360 mm	max. 5 mm < 45 HRC	max. 3,5 mm	max. 8 mm	1
17056	18' 460 mm	max. 6 mm < 45 HRC	max. 5 mm	max. 10 mm	1
17057	24' 610 mm	max. 8 mm < 45 HRC	max. 7 mm	max. 12 mm	1
17058	30' 760 mm	max. 10 mm < 45 HRC	max. 9 mm	max. 14 mm	1
17046	35' 900 mm	max. 12 mm < 45 HRC	max. 10 mm	max. 16 mm	1



FESTA

PÁKOVÉ ŠTIEPACIE KLIESTE PROFESIONÁLNE

Cr-Mo

HRC 58-62

Č.p.	špecifikácia	max. Ø drátu	1
17051	14' 360 mm	max. 5 mm < 45 HRC	1
17052	18' 450 mm	max. 6 mm < 45 HRC	1
17053	24' 610 mm	max. 8 mm < 45 HRC	1
17054	30' 760 mm	max. 10 mm < 45 HRC	1
17048	36' 910 mm	max. 12 mm < 45 HRC	1



PÁKOVÉ ŠTIEPACIE KLIESTE

Č.p.	špecifikácia	max. Ø drátu	30
17028	14' 350 mm	max. 5 mm < 30 HRC	30
17020	18' 450 mm	max. 6 mm < 30 HRC	6
17021	24' 610 mm	max. 8 mm < 30 HRC	10
17022	30' 760 mm	max. 10 mm < 30 HRC	5

NEW



FESTA

PÁKOVÉ ŠTIEPACIE KLIESTE

- mäkký drôt: Ø 6 mm
- stredne tvrdý drôt: Ø 5 mm
- tvrdý drôt: Ø 4 mm

CrV

Č.p.	špecifikácia	
17078	200 mm	12



PÁKOVÉ ŠTIEPACIE KLIESTE

max. Ø
5 mm

Č.p.	špecifikácia	
17038	8" 210 mm	10



FESTA

KLIESTE ŠTIEPACIE ČELNÉ

CrV

Č.p.	špecifikácia	
17300	160 mm	1
17301	180 mm	10
17302	200 mm	6
17303 NEW	250 mm	1



FESTA

KLIESTE RABITOVÉ

CrV

Č.p.	špecifikácia	
17305	220 mm	5
17306 NEW	250 mm	1
17304	275 mm	6



KLIESTE ŠTIEPACIE ČELNÉ

Č.p.	špecifikácia	
17015	160 mm	6
17016	180 mm	6
17017	200 mm	6



KLIESTE RABITOVÉ

Č.p.	špecifikácia	
17019	220 mm	6
17083	275 mm	6



FESTA

KLIEŠTE KLAMPIARSKÉ ROVNÉ

Č.p.	špecifikácia
17089	150 x 215 mm



2



FESTA

KLIEŠTE KLAMPIARSKÉ ROVNÉ

Č.p.	špecifikácia
17093	95 x 270 mm



6



FESTA

KLIEŠTE KLAMPIARSKÉ ROVNÉ

Č.p.	špecifikácia
17090	60 x 280 mm



10



FESTA

KLIEŠTE KLAMPIARSKÉ VYHNUTÉ 45°

Č.p.	špecifikácia
17091	60 x 280 mm



10



FESTA

KLIEŠTE KLAMPIARSKÉ VYHNUTÉ 90°

Č.p.	špecifikácia
17092	60 x 260 mm



10



FESTA

NOŽNICE NA PLECH

Cr-Mo **HRC 58-62**



Č.p.	špecifikácia
17112	rovné 40 260 mm
17117	pravé 40 260 mm
17122	ľavé 40 260 mm



FESTA

NOŽNICE NA PLECH

Cr-Mo **HRC 58-62**



Č.p.	špecifikácia
17111	rovné 40 250 mm
17116	pravé 40 250 mm
17121	ľavé 40 250 mm



FESTA

NOŽNICE NA PLECH

CrV



Č.p.	špecifikácia	
17170	50 250 mm	6



FESTA

NOŽNICE NA PLECH

CrV



Č.p.	špecifikácia	
17156	60 245 mm	6



FESTA

NOŽNICE NA PLECH

CrV



Č.p.	špecifikácia	
17155	70 260 mm	6



NOŽNICE NA PLECH

CrV

Č.p.	špecifikácia	
17167	70 300 mm	5



NOŽNICE NA PLECH

CrV

Č.p.	špecifikácia	
17165	60 250 mm	5



NOŽNICE NA PLECH

CrV

Č.p.	špecifikácia	
17169	35 250 mm	5

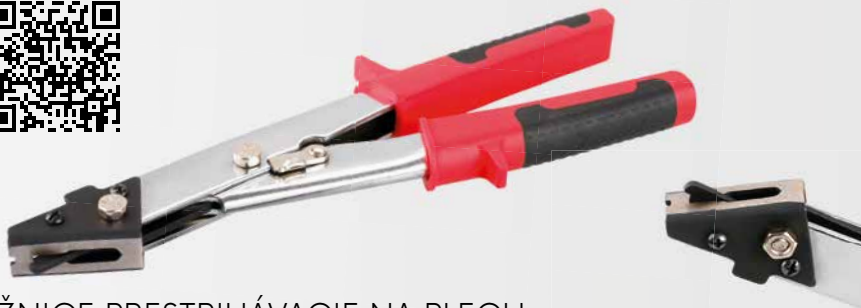

NOŽNICE PRESTRIHÁVACIE NA PLECH

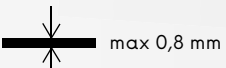

Č.p.	špecifikácia	
17186	265 mm	6



NÁSTAVEC NA STRIHANIE PLECHU

Max. hrúbka plechu

- 1,8 mm - oceľ
- 1,2 mm - nerez
- 2 mm - plasty, hliník, meď

Č.p.	špecifikácia	
20363		5

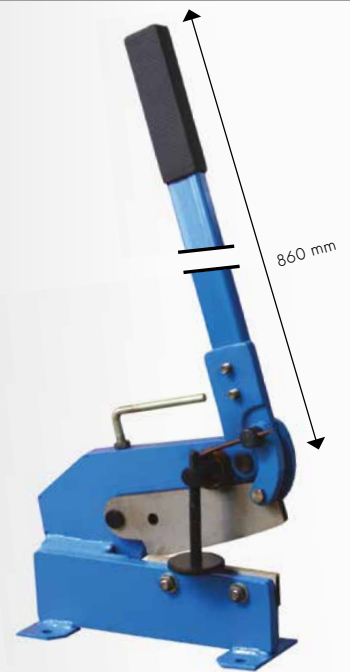

NOŽNICE PÁKOVÉ

	17175	17177
	max. 4mm	5mm
	max. Ø10mm	Ø12mm
	max. 8x8mm	10x10mm

Č.p.	špecifikácia	
17175	150 mm	1
17177	250 mm	1



FESTA

KLIŠTE DIEROVACIE



Č.p.	špecifikácia	
17185	Ø 2; 2,5; 3; 3,5; 4; 4,5 mm	12

FESTA

NOŽNICE NA PVC LIŠTY A RÚRKY

· Použitie pre: lišty, rúrky, profily



Č.p.	špecifikácia	
17050	60 220 mm ø 17 mm, ø 20 mm, ø 27 mm	8



NOŽNICE TECHNICKÉ

INOX



Č.p.	špecifikácia	
16420	60 200 mm	12



NOŽNICE

INOX



Č.p.	špecifikácia	
17159	65 220 mm	12



NOŽNICE TECHNICKÉ

INOX



Č.p.	špecifikácia	
17158	50 150 mm	10



NOŽNICE - SÚPRAVA

INOX

3x



Č.p.	špecifikácia	
16401	3 ks	48



NOŽNICE

INOX



Č.p.	špecifikácia	
17160	70 210 mm	12



NOŽNICE

INOX

Č.p.	špecifikácia	
16405	14 cm	24
16406	17 cm	24
16407	19 cm	24
16408	21,5 cm	12

FESTA®

10 years
guarantee

- použitie v priemysle a servisoch
- kvalitná chróm vanadiová oceľ
- račňa so 72 vybrúsenými zubami pre tú najpresnejšiu prácu
- všetky komponenty podľa DIN normy
- vrúbkované hlavice pre zlepšenie úchopu
- odolné plechové alebo plastové kufre



made by

HONITON

FESTA made by **HONITON**

GOLA SADA

- 1/2" · 72 T
- 1/2" · 125 mm
- 1/2" · 8-9-10-11-12-13-14-15-17-19-22 mm

CrV **1/2"** **13x**

Č.p. špecifikácia

17210



10 years
guarantee



1

FESTA made by **HONITON**

GOLA SADA

- 1/4" · 72 T
- 1/4" · 50 mm, 100 mm
- 1/4" · 4-4,5-5-5,5-6-7-8-9-10-11-12-13 mm

CrV **1/4"** **17x**

Č.p. špecifikácia

17211









10 years
guarantee

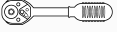

1

FESTA made by **HONITON**

GOLA SADA

-  1/2"
-  1/2" · 125 mm, 250 mm
-  1/2"
-  16 mm, 21 mm
-  1/2"
-  1/2" · 10-11-12-13-14-15-16-17-18-19-20-21-22-23-24-27-30-32 mm

CrV **1/2"** **25x**

Č.p. špecifikácia
17212













10 years guarantee

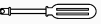

4

FESTA made by **HONITON**

GOLA SADA

-  1/2", 1/4" · 72 T
-  1/2", 1/4"
-  1/4" · 150 mm
-  1/4" · 100 mm
-  1/2", 1/4"
-  1/2" · 125 mm, 250 mm
-  1/4" · 4-4,5-5-5,5-6-7-8-9-10-11-12-13 mm
-  1/2" · 10-11-12-13-14-15-17-19-21-22-24-27-30-32 mm
-  16 mm, 21 mm
-  18x

Inbus 3x

CrV **1/2"** **1/4"** **59x**

Č.p. špecifikácia
17214









10 years guarantee

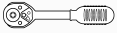

4

FESTA made by **HONITON**

GOLA SADA

-  1/2" · 72 T
-  1/2" · 125 mm, 250 mm
-  1/2"
-  16 mm, 21 mm
-  1/2"
-  1/2"
-  1/2" · 8-9-10-11-12-13-14-15-16-17-18-19-20-21-22-23-24-27-30-32 mm

CrV **1/2"** **28x**

Č.p. špecifikácia
17213







10 years guarantee



4

FESTA made by **HONITON**

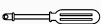
GOLA SADA

-  1/4" · 72 T
-  1/4" · 50 mm
-  1/4"
-  1/4"
-  1/4" · 4-4,5-5-5,5-6-7-8-9-10-11-12-13 mm

CrV **1/4"** **16x**

Č.p. špecifikácia
17215



10 years guarantee



1

FESTA made by **HONLITON**

GOLA SADA

- 1/2" · 72 T
- 1/2" · 125 mm, 250 mm
- 1/2"
- 16 mm, 21 mm
- 1/2"
- 1/2" · 10-11-12-13-14-15-16-17-18-19-20-21-22-23-24-27-30-32 mm

CrV **1/2"** **25x**

Č.p. špecifikácia

17216



10 years guarantee



10

FESTA made by **HONLITON**

GOLA SADA

- 1/4" · 72 T
- 1/4" · 50 mm
- 1/4"
- 1/4"
- 1/4"
- 1/4" · 4-4,5-5-5,5-6-7-8-9-10-11-12-13 mm
- 12x
- Inbus 3x

CrV **1/4"** **32x**

Č.p. špecifikácia

17217



10 years guarantee



1

FESTA made by **HONLITON**

GOLA SADA

- 1/2", 1/4" · 72 T
- 1/2", 1/4"
- 1/4" 150 mm
- 1/4" 100 mm
- 1/2", 1/4"
- 1/2" · 125 mm, 250 mm
- 1/4" · 4-4,5-5-5,5-6-7-8-9-10-11-12-13 mm
- 1/2" · 10-11-12-13-14-15-17-19-21-22-24-27-30-32 mm
- 16 mm, 21 mm
- 16x
- Inbus 3x

CrV **1/4"** **1/2"** **56x**

Č.p. špecifikácia

17218



10 years guarantee



4

FESTA made by **HONLITON**

GOLA SADA

- 1/2", 1/4" · 72 T
- 1/2", 1/4"
- 1/4"
- 1/4" · 50 mm, 100 mm
- 1/2", 1/4"
- 1/2", 1/4"
- 1/2" 125 mm, 250 mm
- 1/4" · 4-4,5-5-5,5-6-7-8-9-10-11-12-13-14 mm
- 1/2" · 10-11-12-13-14-15-17-19-21-22-24-27-30-32 mm
- 1/4" · 6-7-8-9-10-11-12-13 mm
- 1/2" · 14-15-17-19-22 mm
- 16 mm, 21 mm
- 34x
- Inbus 3x

CrV **1/4"** **1/2"** **94x**

Č.p. špecifikácia

17219







10 years guarantee

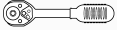
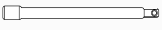
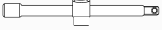

3

FESTA made by **HONITON**

GOLA SADA

-  1/2" · 72 T
-  1/2" · 125 mm, 250 mm
-  1/2"
-  16 mm, 21 mm
-  1/2"
-  1/2" · 8-9-10-11-12-13-14-15-16-17-18-19-20-21-22-23-24-27-30-32 mm

CrV 1/2" 27x





Č.p. špecifikácia
17225



4

FESTA made by **HONITON**

GOLA SADA

-  3/4" · 72 T
-  3/4" · 100 mm, 200 mm
-  3/4" · 460 mm
-  3/4" · 22-24-27-30-32-36-38-41-46-50 mm

CrV 3/4" 14x





Č.p. špecifikácia
17226

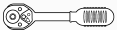

1

FESTA made by **HONITON**

GOLA SADA

-  3/4" · 72 T
-  3/4" · 100 mm, 200 mm, 400 mm
-  3/4" · 460 mm
-  3/4" · 19-21-22-23-24-26-27-29-30-32-35-36-38-41-46-50 mm

CrV 3/4" 21x

Č.p. špecifikácia
17227



1



FESTA made by **HONITON**

SADA HLAVÍC INBUS

-  1/2" HEX · 4-5-6-7-8-10-12-14-17 mm

CrV 1/2" 9x

Č.p. špecifikácia
17345



1



FESTA made by **HONITON**

SADA HLAVÍC TORX

-  T20-T25-T27-T30-T40-T45-T50-T55-T60 mm

CrV 1/2" 9x

Č.p. špecifikácia
17346



1



FESTA made by **HONITON**

HLAVICE NA KOLESÁ

Cr-Mo 1/2" 3x

Č.p.	špecifikácia	
17336	17 mm	5
17337	19 mm	5
17338	21 mm	5



FESTA made by **HONITON**

HLAVICE NA KOLESÁ

1/2" · 17-19-21 mm

Cr-Mo 1/2" 3x

Č.p.	špecifikácia	
17335		1



FESTA made by **HONITON**

RAČŇA

CrV

Č.p.	špecifikácia	
17220	1/4" 36 zubov	20
17222	3/8" 36 zubov	10
17224	1/2" 36 zubov	6
17208	1/2" 72 zubov	6



SADA NÁSTRČNÝCH HLAVÍC DRIVELOCK

4-5-5,5-6-7-8-9-10-11-12-13 mm

CrV 1/4" 12x

Č.p.	špecifikácia	
17250		10



SADA NÁSTRČNÝCH HLAVÍC TORX

1/4" · 5-6-7-8-10

1/2" · 12-14-16-18

CrV 1/2" 1/4" 9x

Č.p.	špecifikácia	
17255		4



FESTA®

10 years
guarantee



Cr-Mo

- použitie v priemysle a servisoch
- vysoko kvalitná chróm vanádiová oceľ
- račňa so 72 vybrúsenými zubami pre tú najpresnejšiu prácu
- všetky komponenty podľa DIN normy
- vrúbkované hlavice pre zlepšenie úchopu
- odolný kufr s kovovými zámkami a kovovými pántami



FESTA

SADA NÁRADIA

- | | |
|--|--|
| 1/2" · 1/4" | 1/4" · S 4 · 5.5 · 6.5 |
| 1/4" · 4-5-6-7-8-9mm | 1/4" · PH 1 · 2 · 3 |
| 1/2" · 10-12-13-14-17-19mm | 1/4" · PZ 2 · 3 |
| 1/4" · 4-4.5-5-5.5-6-7-8-9-10-11-12-13-14mm | 1/4" · H 3 · 4 · 5 · 6 |
| 1/2" · 12-13-14-15-16-17-18-19-20-21-22-24mm | 1/4" · T 8 · 10 · 15 · 20 · 25 |
| 1/2" · 1/4" | 1/4" · TTa · 10 · 15 · 20 · 25 · 40 |
| 1/4" · 1/4" → 1/4" | 2 · 2.5 · 3 · 4 · 5 · 6 · 7 · 8 · 10mm |
| 1/4" · 150mm | 8-9-10-11-12-13-14-15-16-17-18-19mm |
| 1/2" · 254mm | S 4x100 · 6.5x150 |
| 1/2" · 1/4" | PH 2x100 · 3x150 |
| 1/2" · 16-21mm | 180mm |
| 1/4" · 150mm | 160mm |
| 1/2" · E10-E12-E14-E16-E18-E20-E22-E24 | 160mm |
| 1/4" · S 3 · 4 · 5 · 6 | 250mm |
| 1/4" · PH 0 · 1 · 2 | 300g |
| 1/4" · PZ 0 · 1 · 2 | |



CrV S2 1/4" 1/2" 72T 122x ERGO HANDLE

Č.p. 17238
špecifikácia 122 ks



1

FESTA

GOLA SADA

- | |
|---|
| 1/2" · 72T |
| 1/2" · 125 mm |
| 1/2" · 10-11-12-13-14-15-17-19-22-24 mm |

CrV 1/2" 72T 12x ERGO HANDLE

Č.p. 17245
špecifikácia 15

10 years
guarantee



15

FESTA

GOLA SADA

- | |
|---|
| 1/2" · 72T |
| 1/2" · 125 mm |
| 1/2" · 10-11-12-13-14-15-17-19-22-24 mm |

CrV 1/2" 72T 12x ERGO HANDLE

Č.p. 17229
špecifikácia 8

10 years
guarantee



8



FESTA

GOLA SADA

- 1/2" · 72 T
- 1/2" · 75, 125 mm
- 1/2"
- 1/2" · 10-11-12-13-14-15-16-17-18-19-22-24 mm
- 1/2" · 17mm, 19mm
- 3 way adapter
- 16mm, 21mm



Č.p. špecifikácia

17230



4

FESTA

GOLA SADA

- 1/4" · 72 T
- 1/4" · 50, 100 mm
- 1/4"
- 1/4" · 4-5-5,5-6-7-8-10-11-12-13 mm
- 1/4" · 6-7-8-10-12-13 mm
- 3 way adapter
- 4 x
- 11x
- 1x



Č.p. špecifikácia

17231



10

FESTA

GOLA SADA

- 1/4"
- 1/4"
- 1/4" · 4-4,5-5-5,5-6-7-8-9-10-11-12-13-14 mm
- 1/4" · 50 mm, 100 mm
- 1/4"
- 1/4"
- 21 x
- 1/4"
- L 1/4"



Č.p. špecifikácia

17233



10

FESTA

GOLA SADA

- 1/2", 1/4" · 72T
- 1/4"
- 16 mm, 21 mm
- 1/4" · 10-11-12-13-14-15-16-17-18-19-20-21-22-23-24-27 mm
- 1/4" · 100 mm
- 1/2" · 125 mm, 250 mm
- 1/2"
- 1x
- 1/4" · 4-5-5,5-6-7-8-10-11-12-13 mm
- 33 x



Č.p. špecifikácia











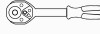
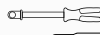

17234

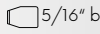

4

FESTA

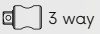
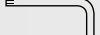
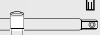
GOLA SADA

-  1/2", 1/4" · 72T
-  1/4"
-  16 mm, 21 mm
-  1/4" · 4 -4,5-5-5,5-6-7-8-9-10-11-12-13-14 mm
-  1/2" · 10-11-12-13-14-15-16-17-18-19-20-21-22-23-24-27-30-32 mm
-  1/4" · 6-7-8-9-10-11-12-13 mm
-  1/2" · 14-15-17-19 mm
-  1/4" · 50 mm, 100 mm
-  1/2" · 125 mm, 250 mm
-  1/4"
-  5/16" bit holder
-  17x
-  15x
-  3 way adapter
-  3 x
-  1/4"
-  L 1/4"
-  1/2", 1/4"

CrV S2 1/4" 1/2" 72T 94x ERGO HANDLE

Č.p. špecifikácia

17235













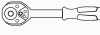
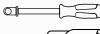



10 years guarantee

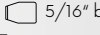

4

FESTA

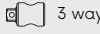
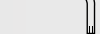
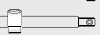
GOLA SADA

-  1/2", 1/4" · 72T
-  150 mm
-  16 mm, 21 mm
-  1/4" · 4 -4,5-5-5,5-6-7-8-9-10-11-12-13-14 mm
-  1/2" · 10-11-12-13-14-15-16-17-18-19-20-21-22-24-27-30-32 mm
-  1/4" · 6-7-8-9-10-11-12-13 mm
-  1/2" · 14-15-17-19-22 mm
-  1/4" · 50 mm, 100 mm
-  1/2" · 125 mm, 250 mm
-  E · 4-5-6-7-8-10-11-12-14-16-18-20-24-27-30-32 mm
-  1/2", 1/4"
-  5/16" bit holder
-  18 x
-  17 x
-  3 way adapter
-  4 x
-  1/4"
-  L 1/4"

CrV S2 1/4" 1/2" 72T 110x ERGO HANDLE

Č.p. špecifikácia

17236























10 years guarantee

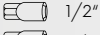
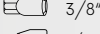
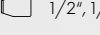

4

FESTA

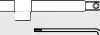
GOLA SADA

-  1/2", 1/4", 3/8"
-  1/4" · 4-5-6-7-8-9-10mm
-  3/8" · 10-11-12-13-14-15mm
-  1/2" · 16-17-18-19-22mm
-  1/4" · 4-4,5-5-5,5-6-7-8-9-10-11-12-13-14mm
-  3/8" · 10-11-12-13-14-15-16-17-18-19mm
-  1/2" · 10-11-12-13-14-15-16-17-18-19-20-21-22-24-27-30-32mm
-  1/4" · E4-E5-E6-E7-E8
-  3/8" · E10-E11-E12-E14-E16-E18
-  1/2" · E20-E24
-  1/2" · 24x
-  1/4" · 20x
-  1/4" · 30x
-  1/4" · 50 mm, 100 mm
-  1/2" · 125 mm, 250 mm
-  3/8" · 150 mm
-  1/2" · 16-21mm
-  3/8" · 18mm
-  1/2", 1/4", 3/8" bit holder
-  1/2", 1/4", 3/8"
-  1/4" · 150mm
-  1/4" · 115mm
-  Inbus 7X

CrV S2 1/4" 1/2" 3/8" 72T 171x ERGO HANDLE

Č.p. špecifikácia

17237



10 years guarantee



2

FESTA®



- račňa je vyrobená z najkvalitnejšej chrom vanadiovej ocele
- račňa so 72 vybrúsenými zubami pre tú najpresnejšiu prácu
- kvalitná, ergonomická, dvojkomponentná rukoväť z mäkkej TPE gúmy
- SYSTÉM QUICK RELEASE pre ľahkú a rýchlu výmenu hlavíc



FESTA®

RAČŇA



Č.p.	špecifikácia	dĺžka	
17297	1/4"	155 mm	6
17298	3/8"	210 mm	5
17299	1/2"	255 mm	4

FESTA®

RAČŇA



Č.p.	špecifikácia	dĺžka	
17240	1/4"	155 mm	10
17241	3/8"	200 mm	10
17242	1/2"	250 mm	5



FESTA®

RAČŇA



Č.p.	špecifikácia	dĺžka	
17294	1/4"	155 mm	6
17295	3/8"	205 mm	10
17296	1/2"	255 mm	4

FESTA®

RAČŇA OTOČNÁ 1/4"



Č.p.	špecifikácia	
17292	1/4"	1



RAČŇA



Č.p.	špecifikácia	
17243	1/4"	25
17244	1/2"	25

FESTA®

SKRUTKOVÁČ NA HLAVICE

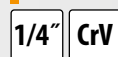

Č.p.	špecifikácia	
18603	1/4" 150 mm	10

NEW



HLAVICA UNIVERZÁLNA



Č.p.	špecifikácia	
17812	10 - 19 mm	1



HLAVICA UNIVERZÁLNA



Č.p.	špecifikácia	
17810	pre skrutky 7 - 19mm • 52mm x ø26mm	1



HLAVICA UNIVERZÁLNA



Č.p.	špecifikácia	
17811	pre skrutky 11 - 32mm • 83mm x ø43mm	5

FESTA

HLAVICA PREDĹŽENÁ 1/4"



Č.p.	špecifikácia		Č.p.	špecifikácia	
17860	4 mm • 50 mm	10	17866	10 mm • 50 mm	10
17861	5 mm • 50 mm	10	17867	11 mm • 50 mm	10
17862	6 mm • 50 mm	10	17868	12 mm • 50 mm	10
17863	7 mm • 50 mm	10	17869	13 mm • 50 mm	10
17864	8 mm • 50 mm	10	17870	14 mm • 50 mm	10
17865	9 mm • 50 mm	10			



FESTA

HLAVICA 1/4"



Č.p.	špecifikácia		Č.p.	špecifikácia	
17820	4 mm • 25 mm	10	17827	9 mm • 25 mm	10
17821	4,5 mm • 25 mm	10	17828	10 mm • 25 mm	10
17822	5 mm • 25 mm	10	17829	11 mm • 25 mm	10
17823	5,5 mm • 25 mm	10	17830	12 mm • 25 mm	10
17824	6 mm • 25 mm	10	17831	13 mm • 25 mm	10
17825	7 mm • 25 mm	10	17832	14 mm • 25 mm	10
17826	8 mm • 25 mm	10			



FESTA

HLAVICA PREDĹŽENÁ 1/2"



Č.p.	špecifikácia		Č.p.	špecifikácia	
17871	10 mm • 70 mm	10	17882	21 mm • 70 mm	10
17872	11 mm • 70 mm	10	17883	22 mm • 70 mm	10
17873	12 mm • 70 mm	10	17884	23 mm • 70 mm	10
17874	13mm • 70 mm	10	17885	24 mm • 70 mm	10
17875	14 mm • 70 mm	10	17886	25 mm • 70 mm	10
17876	15 mm • 70 mm	10	17887	26 mm • 70 mm	10
17877	16 mm • 70 mm	10	17888	27 mm • 70 mm	10
17878	17 mm • 70 mm	10	17889	28 mm • 70 mm	10
17879	18 mm • 70 mm	10	17890	30 mm • 70 mm	10
17880	19 mm • 70 mm	10	17891	32 mm • 70 mm	10
17881	20 mm • 70 mm	10	17892	34 mm • 70 mm	10



FESTA

HLAVICA 1/2"



Č.p.	špecifikácia		Č.p.	špecifikácia	
17308	8 mm • 38 mm	10	17319	19 mm • 38 mm	10
17309	9 mm • 38 mm	10	17320	20 mm • 38 mm	10
17310	10 mm • 38 mm	10	17321	21 mm • 38 mm	10
17311	11 mm • 38 mm	10	17322	22 mm • 38 mm	10
17312	12 mm • 38 mm	10	17324	24 mm • 38 mm	10
17313	13 mm • 38 mm	10	17327	27 mm • 42 mm	20
17314	14 mm • 38 mm	10	17330	30 mm • 42 mm	25
17315	15 mm • 38 mm	10	17332	32 mm • 42 mm	20
17316	16 mm • 38 mm	10	17333	34 mm • 42 mm	20
17317	17 mm • 38 mm	10	17334	36 mm • 42 mm	20
17318	18 mm • 38 mm	10			





FESTA

HLAVICA 3/4"

CrV 3/4"



Č.p.	špecifikácia	
17835	17 mm · 48 mm	10
17836	18 mm · 48 mm	10
17837	19 mm · 48 mm	10
17838	21 mm · 48 mm	10
17839	22 mm · 48 mm	10
17840	24 mm · 48 mm	10
17841	26 mm · 48 mm	10
17842	27 mm · 52 mm	10
17843	28 mm · 52 mm	10
17844	30 mm · 52 mm	10
17845	32 mm · 52 mm	10

Č.p.	špecifikácia	
17846	33 mm · 55 mm	10
17847	36 mm · 60 mm	10
17848	38 mm · 60 mm	10
17849	41 mm · 65 mm	10
17850	46 mm · 65 mm	10
17851	50 mm · 70 mm	10
17852	55 mm · 75 mm	10
17853	60 mm · 78 mm	10
17854	65 mm · 82 mm	10
17855	70 mm · 82 mm	10
17856	75 mm · 88 mm	10



FESTA

HLAVICA MULTILOCK 1/4"

CrV 1/4"



Č.p.	špecifikácia	
17895	4 mm · 25 mm	10
17896	4,5 mm · 25 mm	10
17897	5 mm · 25 mm	10
17898	5,5 mm · 25 mm	10

Č.p.	špecifikácia	
17902	9 mm · 25 mm	10
17904	11 mm · 25 mm	10
17905	12 mm · 25 mm	10
17907	14 mm · 25 mm	10



FESTA

HLAVICA MULTILOCK 1/2"

CrV 1/2"



Č.p.	špecifikácia	
17910	8 mm · 38 mm	10
17912	10 mm · 38 mm	10
17913	11 mm · 38 mm	10
17914	12 mm · 38 mm	10
17916	14 mm · 38 mm	10

Č.p.	špecifikácia	
17922	21 mm · 38 mm	10
17924	24 mm · 38 mm	10
17925	27 mm · 38 mm	10
17926	30 mm · 38 mm	10
17927	32 mm · 38 mm	10



FESTA

HLAVICA TORX 1/4"

CrV 1/4"



Č.p.	špecifikácia	
17930	E4	10
17931	E5	10
17932	E6	10

Č.p.	špecifikácia	
17933	E7	10
17934	E8	10
17935	E10	10



FESTA

HLAVICA TORX 1/2"

CrV 1/2"



Č.p.	špecifikácia	
17943	E22	10
17944	E24	10

Č.p.	špecifikácia	
17943	E22	10
17944	E24	10



FESTA

NÁSTAVEC SKRUTKOVACÍ 1/4"

CrV S2 — 1/4"



Č.p.	špecifikácia	
18920	S 4 mm	10
18921	S 5,5 mm	10
18922	S 7 mm	10



FESTA

NÁSTAVEC SKRUTKOVACÍ 1/4"

CrV S2 + 1/4"



Č.p.	špecifikácia	
18925	PH 1	10
18926	PH 2	10
18927	PH 3	10



FESTA

NÁSTAVEC SKRUTKOVACÍ 1/4"

CrV S2 * 1/4"



Č.p.	špecifikácia	
18928	PZ 0	10
18929	PZ 1	10
18930	PZ 2	10
18931	PZ 3	10



FESTA

NÁSTAVEC SKRUTKOVACÍ 1/2"

CrV S2 1/2"



Č.p.	špecifikácia	
18971	M 16	10



FESTA

NÁSTAVEC SKRUTKOVACÍ 1/4"

CrV S2 1/4"



Č.p.	špecifikácia	
18934	3 mm	10
18937	6 mm	10
18939	8 mm	10



FESTA

NÁSTAVEC SKRUTKOVACÍ 1/2"

CrV S2 1/2"



Č.p.	špecifikácia	
18944	12 mm	10
18945	14 mm	10



FESTA

NÁSTAVEC SKRUTKOVACÍ 1/4"

CrV S2 1/4"



Č.p.	špecifikácia	
18948	T 5	10
18950	T 8	10
18951	T 10	10



FESTA

NÁSTAVEC SKRUTKOVACÍ 1/2"

CrV S2 1/2"



Č.p.	špecifikácia		Č.p.	špecifikácia	
18954	T 10	10	18960	T 40	10
18955	T 15	10	18961	T 45	10
18956	T 20	10	18963	T 55	10
18957	T 25	10			



FESTA
ADAPTÉR

CrV



Č.p.	špecifikácia	
17410	A - 1/4" B - 3/8"	10
17411	A - 3/8" B - 1/4"	10
17412	A - 3/8" B - 1/2"	10
17413	A - 1/2" B - 3/8"	10

Č.p.	špecifikácia	
17414	A - 1/2" B - 3/4"	10
17415	A - 3/4" B - 1/2"	10
17416	A - 1/4" B - 1/2"	10



FESTA
KARDAN

CrV



Č.p.	špecifikácia	
17405	1/4" · 39 mm	10
17406	1/2" · 71 mm	10
17407	3/4" · 105 mm	10



FESTA
JEZDEC NA „T“ VRATIDLO

CrV



Č.p.	špecifikácia	
17420	1/4"	1
17421	1/2"	1
17422	3/4"	1



FESTA
„T“ VRATIDLO

CrV



Č.p.	špecifikácia	
17382	1/4" · 115 mm	1
17383	3/8" · 190 mm	1
17384	1/2" · 250 mm	1
17385	3/4" · 460 mm	1
17386	1" · 640 mm	1



FESTA
„T“ NADSTAVEC PREDĹŽENÝ S KLĚBOM

CrV



Č.p.	špecifikácia	
17401	1/4" · 250 mm	1
17402	1/2" · 400 mm	1



FESTA
VRATIDLO KLĚBOVÉ - TRHÁK

CrV



Č.p.	špecifikácia	
17380	1/2" · 350 mm	1
17381	3/4" · 500 mm	1



FESTA
RUKOVÄŤ OHNUTÁ

CrV 1/2"



Č.p.	špecifikácia	
17427	1/2" · 60 x 320 mm	1

FESTA

NÁSTAVEC PREDLŽOVACÍ

CrV

Č.p.	špecifikácia	
17390	1/4" · 50 mm	1
17391	1/4" · 100 mm	1
17392	1/4" · 150 mm	1
17393	1/2" · 75 mm	1
17394	1/2" · 125 mm	1



FESTA

NÁSTAVEC FLEXIBILNÝ

CrV 1/4"

Č.p.	špecifikácia	
17400	1/4" · 150 mm	1



Stahlberg

ADAPTÉR RAČŇA 1/4"- BIT

CrV

1/4" ↔ 1/4"

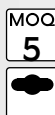

Č.p.	špecifikácia	
18619		5



SÚPRAVA ADAPTÉROV PRE VRŤAČKU

CrV 1/4" 3x

Č.p.	špecifikácia	
18604	1/4", 3/8", 1/2"	10



NEW

KLÚČ NA ODVZDUŠŇOVANIE RADIÁTOROV S NÁDOBOU



Č.p.	špecifikácia	
17459	50 ml	1

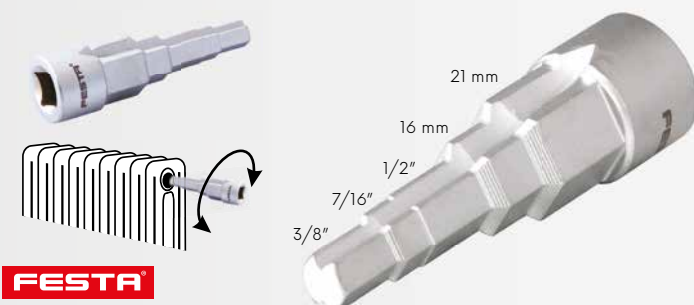

FESTA

KLÚČ NA RADIÁTOROVÉ SKRUTKY

CrV 1/2"

Č.p.	špecifikácia	
17455	pre račňu 1/2"	10



NEW

FESTA

UNIVERZÁLNY KLÚČ K ROZVODNÝM SKRINIAM

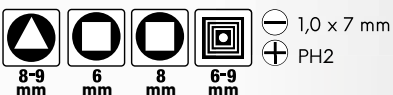

Č.p.	špecifikácia	
17458		1



FESTA

UNIVERZÁLNY KLÚČ K ROZVODNÝM SKRINIAM

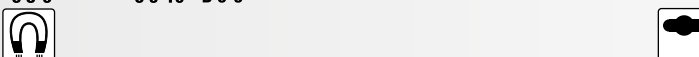
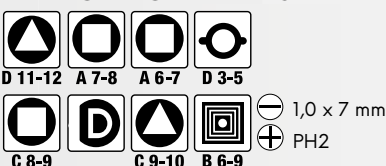

Č.p.	špecifikácia	
17456		50



FESTA[®]

- kované klúče z kvalitnej CrV ocele
- vyrobené podľa DIN normy
- chrómová povrchová úprava



FESTA

KLÚČ OBOJSTRANNÝ OTVORENÝ

CrV **DIN 3110**



Č.p.	špecifikácia	
17550	6 x 7 mm	10
17551	8 x 9 mm	10
17552	8 x 10 mm	10
17553	10 x 11 mm	10
17590	10 x 13 mm	10
17554	12 x 13 mm	10
17555	14 x 15 mm	10
17556	13 x 16 mm	10
17557	13 x 17 mm	10
17591	14 x 17 mm	10
17558	16 x 17 mm	10
17559	17 x 19 mm	10
17560	18 x 19 mm	10

Č.p.	špecifikácia	
17592	19 x 22 mm	10
17593	19 x 24 mm	10
17561	20 x 22 mm	10
17569	21 x 23 mm	10
17548	22 x 24 mm	10
17562	24 x 27 mm	10
17549	24 x 30 mm	10
17563	30 x 32 mm	10
17564	30 x 34 mm	10
17565	32 x 36 mm	10
17566	36 x 41 mm	10
17567	46 x 50 mm	10
17568	50 x 55 mm	3

FESTA

KLÚČ OČKOPLOCHÝ

CrV **DIN 3113**



Č.p.	špecifikácia	
17487	6 mm	10
17570	7 mm	10
17571	8 mm	10
17572	9 mm	10
17573	10 mm	10
17574	11 mm	10
17575	12 mm	10
17576	13 mm	10
17577	14 mm	10
17578	15 mm	10
17579	16 mm	10
17580	17 mm	10
17581	18 mm	10
17582	19 mm	10
17488	20 mm	10

Č.p.	špecifikácia	
17489	21 mm	10
17583	22 mm	10
17490	23 mm	10
17584	24 mm	10
17491	25 mm	10
17492	26 mm	10
17585	27 mm	10
17493	28 mm	10
17494	29 mm	10
17586	30 mm	10
17587	32 mm	10
17495	33 mm	10
17496	34 mm	10
17589	36 mm	10



FESTA

KLÚČ RÁČŇOVÝ KLBOVÝ

CrV **72T**



Č.p.	špecifikácia	
17628	8 mm	10
17622	10 mm	10
17623	13 mm	10
17624	14 mm	10
17629	15 mm	10
17630	16 mm	5

Č.p.	špecifikácia	
17625	17 mm	10
17631	18 mm	10
17626	19 mm	10
17632	21 mm	5
17633	22 mm	5

FESTA

KLÚČ RÁČŇOVÝ

CrV **72T**



Č.p.	špecifikácia	
17660	6 mm	10
17676	7 mm	10
17661	8 mm	10
17662	9 mm	10
17663	10 mm	10
17664	11 mm	10
17665	12 mm	10
17666	13 mm	10
17667	14 mm	10
17668	15 mm	10

Č.p.	špecifikácia	
17669	16 mm	10
17670	17 mm	10
17671	18 mm	10
17672	19 mm	10
17674	21 mm	5
17675	22 mm	5
17677	24 mm	5
17678	27 mm	5
17679	30 mm	5
17683	32 mm	5



FESTA

KLÍČ OČKOVÝ, VYHNUTÝ

CrV DIN 838

Č.p.	špecifikácia	
17605	6 x 7 mm	10
17606	8 x 9 mm	10
17607	8 x 10 mm	10
17608	10 x 11 mm	10
17609	12 x 13 mm	10
17611	13 x 16 mm	10
17612	13 x 17 mm	10

Č.p.	špecifikácia	
17610	14 x 15 mm	10
17613	16 x 17 mm	10
17614	18 x 19 mm	10
17615	20 x 22 mm	10
17616	24 x 27 mm	10
17617	30 x 32 mm	10

FESTA

KLÍČ OBOJSTRANNÝ OTVORENÝ DIN 895

DIN 895

Č.p.	špecifikácia	
17460	6 x 7 mm	10
17461	8 x 9 mm	10
17462	8 x 10 mm	10
17463	10 x 11 mm	10
17481	10 x 13 mm	10
17464	12 x 13 mm	10
17465	14 x 15 mm	10
17466	13 x 16 mm	10
17467	13 x 17 mm	10
17482	14 x 17 mm	10
17468	16 x 17 mm	10

Č.p.	špecifikácia	
17469	17 x 19 mm	10
17470	18 x 19 mm	10
17483	19 x 22 mm	10
17484	19 x 24 mm	10
17471	20 x 22 mm	10
17472	24 x 27 mm	10
17486	21 x 23 mm	10
17480	28 x 30 mm	10
17473	30 x 32 mm	10
17485	36 x 41 mm	10



FESTA

KLÍČ OBOJSTRANNÝ OTVORENÝ

CrV DIN 3110

Č.p.	špecifikácia	
17761	14 x 15 mm	10
17769	20 x 22 mm	10

FESTA

KLÍČ OČKOPLOCHÝ

CrV DIN 3113

Č.p.	špecifikácia	
17788	14 mm	10
17789	15 mm	10

Č.p.	špecifikácia	
17795	21 mm	10
17806	33 mm	10



KLÍČ UNIVERZÁLNY

Cr-Mo

Č.p.	špecifikácia	
17685	12-13-14-15-16-17-18-19 mm	1

FESTA

KLÍČ NASTAVITEĽNÝ

CrV

Č.p.	rozsah	délka	
17197	0 - 29 mm	200 mm	1
17198	0 - 33 mm	250 mm	1
17199	0 - 38 mm	300 mm	1

KLÍČ NASTAVITEĽNÝ

Č.p.	rozsah	délka	
17200	0 - 24 mm	200 mm	6
17201	0 - 30 mm	250 mm	6
17202	0 - 34 mm	300 mm	6



FESTA

KLÍČ OBOJSTRANNÝ OTVORENÝ - SÚPRAVA

CrV

DIN 3110



Č.p.	špecifikácia	
17506	6 ks · 6 x 7, 8 x 9, 10 x 11, 12 x 13, 14 x 15, 16 x 17	1
17508	8 ks · 6 x 7, 8 x 9, 10 x 11, 12 x 13, 14 x 15, 16 x 17, 18 x 19, 20 x 22	1



FESTA

KLÍČ OČKOPLOCHÝ SÚPRAVA

CrV

DIN 3113



Č.p.	špecifikácia	
17526	6 ks · 10 x 10, 11 x 11, 13 x 13, 14 x 14, 16 x 16, 17 x 17	1
17528	8 ks · 8 x 8, 10 x 10, 11 x 11, 13 x 13, 14 x 14, 16 x 16, 17 x 17, 19 x 19	1



FESTA

KLÍČ OČKOVÝ VYHNUTÝ - SÚPRAVA

CrV

DIN 838

8x



Č.p.	špecifikácia	
17539	6 x 7, 8 x 9, 10 x 11, 12 x 13, 14 x 15, 16 x 17, 18 x 19, 20 x 22	1



FESTA

KLÍČ OBOJSTRANNÝ OTVORENÝ - SÚPRAVA

CrV

DIN 3110

12x



Č.p.	špecifikácia	
17512	6 x 7, 8 x 9, 10 x 11, 12 x 13, 14 x 15, 16 x 17, 18 x 19, 20 x 22, 21 x 23, 24 x 27, 25 x 28, 30 x 32	1



FESTA

KLÍČ OČKOPLOCHÝ - SÚPRAVA

CrV

DIN 3113



Č.p.	špecifikácia	
17532	12 ks · 8 x 8, 9 x 9, 10 x 10, 11 x 11, 13 x 13, 14 x 14, 16 x 16, 17 x 17, 18 x 18, 19 x 19, 21 x 21, 22 x 22	10
17533	18 ks · 6 x 6, 7 x 7, 8 x 8, 9 x 9, 10 x 10, 11 x 11, 12 x 12, 13 x 13, 14 x 14, 15 x 15, 16 x 16, 17 x 17, 18 x 18, 19 x 19, 20 x 20, 21 x 21, 22 x 22, 24 x 24	1
17534	25 ks · 6 x 6, 7 x 7, 8 x 8, 9 x 9, 10 x 10, 11 x 11, 12 x 12, 13 x 13, 14 x 14, 15 x 15, 16 x 16, 17 x 17, 18 x 18, 19 x 19, 20 x 20, 21 x 21, 22 x 22, 23 x 23, 24 x 24, 25 x 25, 26 x 26, 27 x 27, 28 x 28, 30 x 30, 32 x 32	4



FESTA

KLÍČ OBOJSTRANNÝ OTVORENÝ - SÚPRAVA

DIN 895



Č.p.	špecifikácia	
17475	8 ks · 6 x 7, 8 x 9, 10 x 11, 12 x 13, 14 x 15, 16 x 17, 18 x 19, 20 x 22	5
17476	12 ks · 6 x 7, 8 x 9, 10 x 11, 12 x 13, 14 x 15, 16 x 17, 18 x 19, 20 x 22, 21 x 23, 24 x 27, 28 x 30, 30 x 32	3



FESTA

KLÍČ RÁČŇOVÝ - SADA

CrV 72T 7x

Č.p.	špecifikácia	
17620	8, 10, 12, 13, 14, 17, 19	5



FESTA

KLÍČ RÁČŇOVÝ, KLÍBOVÝ - SADA

CrV 72T 7x

Č.p.	špecifikácia	
17621	10, 12, 13, 14, 15, 17, 19	5



FESTA

KLÍČ RÚRKOVÝ - SADA

CrV 7x

Č.p.	špecifikácia	
17501	6 x 7, 8 x 9, 10 x 11, 12 x 13, 14 x 15, 16 x 17, 18 x 19	20
17640	páka na rúrkové kľúče · 135 mm	50



FESTA

KLÍČ HÁKOVÝ

CrV

Č.p.	špecifikácia	
17680	19 - 51 mm 165 mm	5
17681	32 - 76 mm 216 mm	5
17682	51 - 121 mm 267 mm	5

FESTA

KLÍČ TRUBKOVÝ

CrV

Č.p.	špecifikácia		Č.p.	špecifikácia	
17650	6 x 7 mm	10	17655	16 x 17 mm	10
17651	8 x 9 mm	10	17645	16 x 18 mm	10
17642	8 x 10 mm	10	17653	16 x 21 mm	10
17652	10 x 11 mm	10	17656	18 x 19 mm	10
17643	12 x 13 mm	10	17657	19 x 22 mm	10
17654	14 x 15 mm	10	17659	22 x 24 mm	10
17644	14 x 17 mm	10	17658	24 x 27 mm	10



KLÍČ PRE UHLOVÉ BRÚSKY, NASTAVITEĽNÝ

Č.p.	špecifikácia	
20967	200 mm	15



KLÍČ NA UHLOVÉ BRÚSKY

Č.p.	špecifikácia	
20968	200 mm	1



FESTA

KLÚČ MOMENTOVÝ

Č.p.	špecifikácia	
17203	1/4" 5 - 25 Nm	1
17204	1/2" 19 - 110 Nm	1
17205	1/2" 42 - 210 Nm	1
17206	3/4" 140 - 700 Nm	1



FESTA

RAČŇA LEŠENÁRSKA

Č.p.	špecifikácia	
17451	18 mm	10
17450	19 mm	10



KLÚČ NA KOLESÁ



Č.p.	špecifikácia	
17600	17, 19, 22 mm, 13/16"	16

KLÚČ NA KOLESÁ



Č.p.	špecifikácia	
17601	17, 19, 21 mm	20



KLÚČ TELESKOPICKÝ NA KOLESÁ



Č.p.	špecifikácia	
17603	17 x 19 mm, 21 x 23 mm	20



KLÚČ NÁSTRČNÝ KLBOVÝ



Č.p.	špecifikácia	
17261	16 mm	1
17262	21 mm	1



FESTA

DRŽIAK MAGNETICKÝ



Č.p. špecifikácia

70098

12

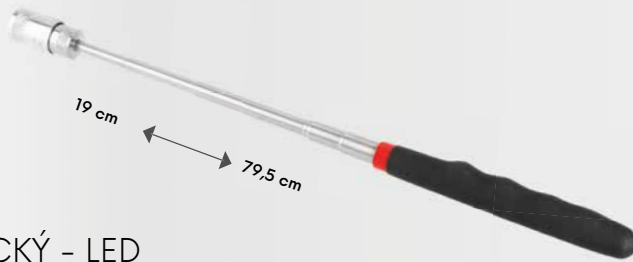

FESTA

TELESKOP MAGNETICKÝ - LED



Č.p. špecifikácia

13294

6

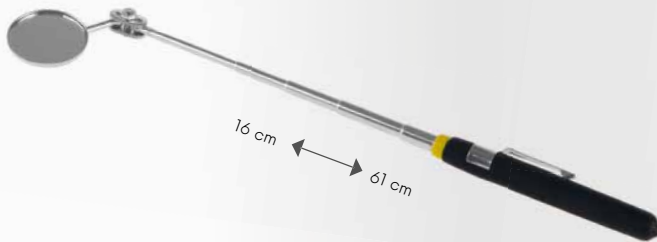

ZRKADLO INŠPEKČNÉ TELESKOPICKÉ



Č.p. špecifikácia

13290

20

Č.p. špecifikácia

13293

20

TELESKOP MAGNETICKÝ

FESTA[®]

- dřík z kvalitnej S2 ocele
- magnetické koncovky
- ergonomická dvojkomponentná rukoväť s mäčkou TPE gumou



FESTA
SKRUTKOVAČ PLOCHÝ

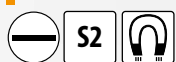

Č.p.	špecifikácia	
18113	3 x 75 mm	12
18114	4 x 100 mm	12
18115	5,5 x 125 mm	12
18116	6,5 x 150 mm	12
18118	8 x 175 mm	6
18120	10 x 200 mm	6



FESTA
SKRUTKOVAČ PLOCHÝ KRÁTKY

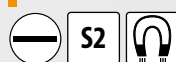

Č.p.	špecifikácia	
18124	5,5 x 38 mm	12
18125	6,5 x 38 mm	12



FESTA
SKRUTKOVAČ PHILIPS



Č.p.	špecifikácia	
18210	0 x 75 mm	12
18211	1 x 75 mm	12
18212	2 x 100 mm	12



FESTA
SKRUTKOVAČ PHILIPS KRÁTKY



Č.p.	špecifikácia	
18215	1 x 38 mm	12
18216	2 x 38 mm	12



FESTA
SKRUTKOVAČ POZIDRIVE

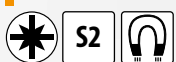

Č.p.	špecifikácia	
18310	0 x 75 mm	12
18311	1 x 100 mm	12
18312	2 x 100 mm	12
18313	3 x 150 mm	6



FESTA
SKRUTKOVAČ POZIDRIVE KRÁTKY

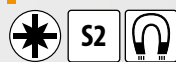

Č.p.	špecifikácia	
18321	1 x 38 mm	12
18322	2 x 38 mm	12



FESTA

SKRUTKOVÁČ TORX



Č.p.	špecifikácia	
18350	T6	12
18351	T7	12
18352	T8	12
18353	T9	12
18354	T10	12
18355	T15	12



FESTA

NÁSTRČNÝ SKRUTKOVÁČ



Č.p.	špecifikácia	
18455	6 mm	12
18456	7 mm	12
18460	13 mm	12



FESTA

SKRUTKOVÁČ ÚDEROVÝ PLOCHÝ



Č.p.	špecifikácia		Č.p.	špecifikácia	
18062	5,5 x 100 mm	12	18065	10 x 175 mm	6
18063	7 x 125 mm	6	18066	10 x 200 mm	6
18064	8 x 150 mm	8	18067	10 x 250 mm	6



FESTA

VDE SKRUTKOVÁČ ELEKTRO PLOCHÝ



Č.p.	špecifikácia	
18088	3 x 75 mm S2	12
18089	4 x 100 mm CrV	12
18090	5,5 x 125 mm CrV	12
18091	6,5 x 150 mm CrV	12
18092	8 x 175 mm CrV	12



FESTA

SKRUTKOVÁČ ÚDEROVÝ PHILIPS



Č.p.	špecifikácia	
18070	PH 1 x 80 mm	8
18071	PH 2 x 100 mm	12
18072	PH 3 x 150 mm	6



FESTA

VDE SKRUTKOVÁČ ELEKTRO PHILIPS



Č.p.	špecifikácia	
18080	PH 0 x 60 mm S2	12
18081	PH 1 x 80 mm CrV	12
18082	PH 2 x 100 mm CrV	12
18083	PH 3 x 150 mm CrV	12



FESTA

SKRUTKOVÁČ ÚDEROVÝ POZIDRIVE



Č.p.	špecifikácia	
18075	PZ 1 x 80 mm	12
18076	PZ 2 x 100 mm	12
18077	PZ 3 x 150 mm	6



FESTA

VDE SKRUTKOVÁČ ELEKTRO POZIDRIVE



Č.p.	špecifikácia	
18084	PZ 0 x 60 mm S2	12
18085	PZ 1 x 80 mm CrV	12
18086	PZ 2 x 100 mm CrV	12
18087	PZ 3 x 150 mm CrV	12





FESTA

SADA SKRUTKOVÁČOV

⊖ S 3x75 · 5x100 · 6x175mm

⊕ PH 0 · 1 · 2 · 3



Č.p. 18402 špecifikácia

6



FESTA

SADA SKRUTKOVÁČOV A BITOV

⊖ S 3 x 75 · 4x100 · 5,5x125 · 6,5 x 150mm

⊕ PH 1 x 100 · 2 x 100mm

○ adapter 1/4"

bity: ⊖ S 4 · 5 · 6 · 7

⊕ PH 1 · 2 · 3

⊛ PZ 1 · 2 · 3

⊛ T 10 · 15 · 20 · 25 · 30

● H 2 · 3 · 4 · 5 · 6



Č.p. 18422 špecifikácia

27 ks

6



FESTA

SADA SKRUTKOVÁČOV

⊖ S 3x75 · 5x100 · 6x150mm

⊕ PH 0 · 1 · 2



Č.p. 18403 špecifikácia

6



FESTA

SADA SKRUTKOVÁČOV

⊖ S 3x60 · 6x100 · 6x125mm

⊛ PZ 0 · 1 · 2



Č.p. 18404 špecifikácia

6



FESTA

SADA SKRUTKOVÁČOV TORX

⊛ T 10 · 15 · 20 · 25 · 30



Č.p. 18340 špecifikácia

6

FESTA

SADA SKRUTKOVÁČOV

⊖ S 6x38 · 5x75 · 6x100 · 8x150mm
2,5x50 · S 3x50mm

⊕ PH 2x38 · 1x75 · 2x100 · 3x150mm
0x50 · 00x50mm

⊛ T 5x50 · 6x50 · 7x50 · 8x50 · 9x50 · 10x50mm



Č.p. 18424 špecifikácia

18424

6



FESTA

SADA ÚDEROVÝCH SKRUTKOVAČOV

⊖ S 5 · 6 · 8 mm

⊕ PH 1 · 2 · 3

CrV **6x**



Č.p. špecifikácia
18423

10



FESTA

SADA ELEKTRO SKRUTKOVAČOV

⊖ S 4x100 · 5,5x125 mm · elektro skúšačka 0 - 250 V

⊕ PH 0x60 · 1x80 · 2x100 mm

⊖ ⊕ **6x** 1000 V IEC/EN60900

Č.p. špecifikácia
18413

6



FESTA

SKRUTKOVAČ ÚDEROVÝ

⊖ S 7 x 35 · 8 x 35 · 8 x 70 mm

⊕ PH 2 x 35 · 3 x 35 · 3 x 70 mm

CrV **6x**



Č.p. špecifikácia
18411

1



FESTA

SADA ELEKTRO SKRUTKOVAČOV

⊖ S 4x100 · 5.5x125 · 6.5x150 mm · elektro skúšačka 0 - 250 V

⊕ PH 0x75 · 1x100 · 2x100 mm

⊖ ⊕ **7x** 1000 V IEC/EN60900:2004

Č.p. špecifikácia
18410

40



FESTA

OTVÁRAČ

Č.p. špecifikácia
18437



5



ELEKTRO SKÚŠAČKA

DIN VDE 0680
73/23 EEC

⊖

Č.p. špecifikácia
18426 0 - 250 V



1



SKRUTKOVÁČ PLOCHÝ



Č.p.	špecifikácia	
18101	4 x 75 mm	10
18102	4 x 100 mm	10
18103	5,5 x 100 mm	10
18104	5,5 x 125 mm	10
18105	6,5 x 100 mm	10
18106	6,5 x 125 mm	10
18107	8 x 160 mm	10
18108	10 x 160 mm	10



SADA SKRUTKOVÁČOV A BITOV

⊖ S 3x75 · 4x75 · 6x100 · 8x150 mm

⊕ PH 1x75 · 2x100 mm

⊙ adapter 1/4"

bity: ⊖ S 4 · 5 · 6 · 7 mm

⊕ PH 1 · 2 · 3

⊕ PZ 1 · 2 · 3

⊕ T10 · 15 · 20

⊙ ↔ ⊙ adapter



Č.p.	špecifikácia	
18418		10



SKRUTKOVÁČ PHILIPS



Č.p.	špecifikácia	
18201	0 x 75 mm	10
18202	1 x 75 mm	10
18203	2 x 100 mm	10
18204	3 x 150 mm	10



SADA SKRUTKOVÁČOV

⊖ S 3x60 · 4x75 · 6x100 · 6x125 mm

⊕ PH 0x60 · 1x75 · 2x100 mm



Č.p.	špecifikácia	
18400		10



SKRUTKOVÁČ POZIDRIVE



Č.p.	špecifikácia	
18301	0 x 75 mm	10
18302	1 x 75 mm	10
18303	2 x 100 mm	10
18304	3 x 150 mm	10



SADA SKRUTKOVÁČOV

⊖ S 3x60 · 6x100 · 6x125 mm

⊕ PH 1x75 · 2x100 mm



Č.p.	špecifikácia	
18401		1



FESTA

T SKRUTKOVÁČ NA BITY S RAČŇOU

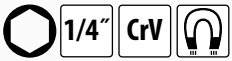

Č.p. 18608 špecifikácia



6



FESTA

SKRUTKOVÁČ NA BITY S RAČŇOU

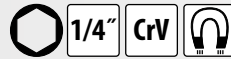

Č.p. 18433 špecifikácia



6



FESTA

SKRUTKOVÁČ NA BITY



Č.p. 18110 špecifikácia



12



FESTA

FLEXI SKRUTKOVÁČ NA BITY



Č.p. 18451 špecifikácia



12



FESTA

SKRUTKOVÁČ NA BITY + 7 BITOV

- ⊖ S 5 · 6 mm
- ⊕ PH 1 · 2 · 3
- ⊛ T 15 · 20

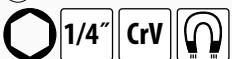

Č.p. 18425 špecifikácia



10

FESTA

FLEXI SKRUTKOVÁČ NA HADICOVÉ SPONY



Č.p. 18450 špecifikácia 7 mm



6





FESTA

SKRUTKOVAČ RAČŇOVÝ S BITMI

1/4" \longleftrightarrow 1/4"

- S 3 · 4 · 5 · 6 · 7 · 5 L
- PH 1 · 2 · 3 · 1 L · 2 L
- PZ 1 · 2 · 3 · 1 L · 2 L
- H 2 · 2.5 · 3 · 4 · 5 · 6
- T 10 · 15 · 20 · 25 · 27 · 30
- SQ 0 · 1 · 2 · 3
- 1/4" 5 · 6 · 7 · 8 · 9 · 10 · 11 · 12 · 13 mm

1/4" **45x**



Č.p. 18419 špecifikácia

6



FESTA

SADA MINI SKRUTKOVAČOV

- S 1,5x50 · 2x50 · 2,5x50 mm
- PH 000x50 · 00x50 · 0x50 mm

6x



Č.p. 18416 špecifikácia

6



FESTA

SADA MINI ELEKTRO SKRUTKOVAČOV

- S 2,4 · 3,0 mm
- PH 0 · 1
- T 6 · 8

6x



Č.p. 18415 špecifikácia

10



FESTA

T SKRUTKOVAČ + 20 NÁSTAVCOV

- S 3 · 4 · 5 · 6 · 8 mm
- PH 0 · 1 · 2 · 3
- adapter + 5 · 6 · 7 · 8 · 9 · 10 · 11 · 12 · 13 mm

1/4" **20x**



Č.p. 18420 špecifikácia

5



FESTA

SADA MINI SKRUTKOVAČOV TORX

- T 4 · 5 · 6 · 7 · 8 · 9 · 10x50 mm

7x



Č.p. 18417 špecifikácia

6



FESTA

SKRUTKOVAČ S MINI BITMI

- S 1.5 · 2 · 2.5 · 3 · 3.5 mm
- PH 000 · 00 · 0 · 1
- PZ 0 · 1
- T 5 · 6 · 7 · 8 · 9 · 10 · 15 · 20
- H 0.9 · 1.3 · 2.0 · 2.5 · 3.0 · 4.0

50x



Č.p. 18431 špecifikácia

6



SKRUTKOVÁČE HODINÁRSKE

⊖ S 1,4 · 2,0 · 2,4 · 3,0 mm

⊕ PH 0 · 1

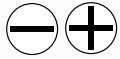

6x HOBBY



Č.p. 18408 špecifikácia

10

SKRUTKOVÁČE HODINÁRSKE

⊖ S 1,0 · 1,2 · 1,4 · 1,8 · 2,4 · 3,0 mm

⊕ PH 00 · 0 · 1

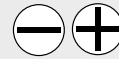

11x HOBBY



Č.p. 18409 špecifikácia

48



UHLOVÝ NADSTAVEC NA BITY 90°



Č.p. 18910



25

RAČŇA NA BITY



Č.p. 18435 špecifikácia 93 mm



1



 **Stahlberg**



Stahlberg

bity - profesionálne skrutkovacie nástavce z vysoko legovanej ocele S2

VÝROBCA STAHLBERG

Značka svetového výrobcu skrutkovacích nástavcov s mnohoročnými skúsenosťami v odbore a so zákazníkmi po celom svete. Pri výrobe používa najnovšie technológie, najlepšie doteraz vyvinuté materiály a povrchové úpravy.

Technológia výroby

krížové a ploché skrutkovacie nástavce sú vyrábané špeciálnou technológiou presného kovania. Tá umožňuje dosiahnutie vysokej presnosti tvaru a súčasne zvýšenie pevnosti oproti obrábaným bitom až o 20%. Po kovaní sú bity kalené pre získanie optimálnej tvrdosti a húževnatosti.



TiN vrstva

vrstva nitrid titánu nanosená na povrch skrutkovacieho hrotu maximálne zvyšuje tvrdosť povrchu, oteruvzdornosť a trecie vlastnosti zabraňujúce vyšmyknutiu zo záberu.



Diamantové zrná

na povrchu hrotu sa doslova „zahryznú“ do hlavy vrtu či skrutky a udrží bit v zábere pre prenos maximálneho krútiaceho momentu. Sú najlepšou zárukou zotrvania v zábere. Najčastejšie sa skrutkovací bit totiž poškodí pri vyšmyknutí zo záberu. Krútiaci moment sa v tú chvíľu prenáša na minimálnu plochu, ktorá sa deformuje.



Protišmykové drážky

na pracovných plochách skrutkovacích hrotov vyrobených kovaním sú ďalšou veľmi účinnou obranou proti vyšmyknutiu hrotu zo záberu.



NEW

Stahlberg

BIT PH



S2

2x



Č.p.	špecifikácia	
18632A	PH2 x 25 mm	1
18633A	PH3 x 25 mm	1

NEW

Stahlberg

BIT PZ



S2

2x



Č.p.	špecifikácia	
18636A	PZ1 x 25 mm	1
18637A	PZ2 x 25 mm	1
18638A	PZ3 x 25 mm	1

NEW

Stahlberg

BIT T



S2

2x



Č.p.	špecifikácia	
18827A	T20 x 25 mm	1
18828A	T25 x 25 mm	1
18830A	T30 x 25 mm	1
18831A	T40 x 25 mm	1

Stahlberg

BIT PH DIAMANT



DIN 3128

S2 TiN



MOQ 5



Č.p.	špecifikácia	
18770	PH1 x 25 mm	5
18771	PH2 x 25 mm	5
18772	PH3 x 25 mm	5

Stahlberg

BIT PZ DIAMANT



DIN 3128

S2 TiN



MOQ 5



Č.p.	špecifikácia	
18775	PZ1 x 25 mm	5
18776	PZ2 x 25 mm	5
18777	PZ3 x 25 mm	5

Stahlberg

BIT S



S2



MOQ 5



Č.p.	špecifikácia	
18620	S 3 x 25 mm	5
18621	S 4 x 25 mm	5
18623	S 5 x 25 mm	5
18625	S 6 x 25 mm	5
18627	S 7 x 25 mm	5
18628	S 8 x 25 mm	5

Stahlberg

BIT PH



S2



MOQ 5



Č.p.	špecifikácia	
18630	PH0 x 25 mm	5
18631	PH1 x 25 mm	5
18632	PH2 x 25 mm	5
18633	PH3 x 25 mm	5
18634	PH4 x 25 mm	5

Stahlberg

BIT PZ



S2



MOQ 5



Č.p.	špecifikácia	
18635	PZ0 x 25 mm	5
18636	PZ1 x 25 mm	5
18637	PZ2 x 25 mm	5
18638	PZ3 x 25 mm	5
18639	PZ4 x 25 mm	5

Stahlberg

BIT PH



S2



MOQ 25



Č.p.	špecifikácia	
18685	PH2 x 25 mm	25

Stahlberg

BIT PZ



S2



MOQ 25



Č.p.	špecifikácia	
18680	PZ2 x 25 mm	25

Stahlberg

BIT PH



S2



MOQ 10



Č.p.	špecifikácia	
18640	PH1 x 70 mm	10
18641	PH2 x 70 mm	10

Stahlberg

BIT PZ



S2



MOQ 10



Č.p.	špecifikácia	
18645	PZ1 x 70 mm	10
18646	PZ2 x 70 mm	10

Stahlberg

BIT PH



S2 TiN



MOQ 5



Č.p.	špecifikácia	
18760	PH0 x 25 mm	5
18761	PH1 x 25 mm	5
18762	PH2 x 25 mm	5
18763	PH3 x 25 mm	5
18764	PH4 x 25 mm	1

Stahlberg

BIT PZ



S2 TiN



MOQ 5



Č.p.	špecifikácia	
18765	PZ0 x 25 mm	5
18766	PZ1 x 25 mm	5
18767	PZ2 x 25 mm	5
18768	PZ3 x 25 mm	5
18769	PZ4 x 25 mm	5

Stahlberg

BIT S



S2 TiN



MOQ 5



Č.p.	špecifikácia	
18750	S 3 x 25 mm	5
18751	S 4 x 25 mm	5
18753	S 5 x 25 mm	5
18755	S 6 x 25 mm	5

Stahlberg

BIT H



S2



MOQ 5



Č.p.	špecifikácia	
18800	H 1,5 x 25 mm	5
18801	H 2,0 x 25 mm	5
18802	H 2,5 x 25 mm	5
18803	H 3,0 x 25 mm	5
18804	H 4,0 x 25 mm	5
18805	H 5,0 x 25 mm	5
18806	H 5,5 x 25 mm	5
18807	H 6,0 x 25 mm	5

Stahlberg

BIT TTA



S2



MOQ 5



Č.p.	špecifikácia	
18835	TTa 5 x 25 mm	10
18836	TTa 6 x 25 mm	5
18837	TTa 7 x 25 mm	5
18838	TTa 8 x 25 mm	5
18839	TTa 9 x 25 mm	5
18840	TTa 10 x 25 mm	5
18841	TTa 15 x 25 mm	5
18842	TTa 20 x 25 mm	5
18843	TTa 25 x 25 mm	5
18844	TTa 27 x 25 mm	5
18845	TTa 30 x 25 mm	5
18846	TTa 40 x 25 mm	5
18847	TTa 45 x 25 mm	5

Stahlberg

BIT T



S2



MOQ 5



Č.p.	špecifikácia	
18820	T5 x 25 mm	5
18821	T6 x 25 mm	5
18822	T7 x 25 mm	5
18823	T8 x 25 mm	5
18824	T9 x 25 mm	5
18825	T10 x 25 mm	5
18826	T15 x 25 mm	5
18827	T20 x 25 mm	5
18828	T25 x 25 mm	5
18829	T27 x 25 mm	5
18830	T30 x 25 mm	5
18831	T40 x 25 mm	5
18832	T45 x 25 mm	5

Stahlberg

BIT HTA



S2



MOQ 5



Č.p.	špecifikácia	
18810	HTa 1,5 x 25 mm	5
18811	HTa 2,0 x 25 mm	5
18812	HTa 2,5 x 25 mm	5
18813	HTa 3,0 x 25 mm	5
18814	HTa 4,0 x 25 mm	5
18815	HTa 5,0 x 25 mm	5
18816	HTa 5,5 x 25 mm	5
18817	HTa 6,0 x 25 mm	5

Stahlberg

BIT T



S2



MOQ 3



Č.p.	špecifikácia	
17980	T30 x 35 mm	3
17981	T40 x 35 mm	3

Č.p.	špecifikácia	
17982	T45 x 35 mm	3
17983	T50 x 35 mm	3

Stahlberg

BIT SQ



S2



MOQ 5



Č.p.	špecifikácia	
18850	SQ 0 x 25 mm	5
18851	SQ 1 x 25 mm	5
18852	SQ 2 x 25 mm	5
18853	SQ 3 x 25 mm	5

Stahlberg

BIT T



S2



MOQ 3



Č.p.	špecifikácia	
17970	T20 x 75 mm	3
17971	T25 x 75 mm	3
17972	T30 x 75 mm	3
17973	T40 x 75 mm	3

Č.p.	špecifikácia	
17974	T45 x 75 mm	3
17975	T50 x 75 mm	3
17976	T55 x 75 mm	3

Stahlberg

BIT SD



S2



MOQ 5



Č.p.	špecifikácia	
18855	SD 6 x 25 mm	5
18856	SD 8 x 25 mm	5

Stahlberg

BIT TS



S2



MOQ 5



Č.p.	špecifikácia	
18864	TS 4 x 25 mm	5
18865	TS 6 x 25 mm	5

Stahlberg

BIT



S2



MOQ 5



Č.p.	špecifikácia	
18866	5/32 x 25 mm	5
18867	3/16 x 25 mm	5

Stahlberg

BIT TW



S2



MOQ 5



Č.p.	špecifikácia	
18860	TW 1 x 25 mm	5
18861	TW 2 x 25 mm	5
18862	TW 3 x 25 mm	5
18863	TW 4 x 25 mm	5



Stahlberg

BIT XZN



Č.p.	špecifikácia	
18870	M4 x 25 mm	5
18871	M5 x 25 mm	5
18872	M6 x 25 mm	5
18873	M8 x 25 mm	5
18874	M10 x 25 mm	5



Stahlberg

BIT NA SADROKARTÓN



2x

Č.p.	špecifikácia	
18795	PH 2 x 25 mm	24



Stahlberg

BIT NA SADROKARTÓN



2x

Č.p.	špecifikácia	
18796	PH 2 x 55 mm	24



Stahlberg

BIT ADAPTÉR



1/4" ↔ 1/4"



Č.p.	špecifikácia	
18868	25 mm	5



Stahlberg

BIT ADAPTÉR



1/4" ↔ 1/4"



Č.p.	špecifikácia	
18869	50 mm	5



Stahlberg

ADAPTÉR RAČŇA 1/4' - BIT



1/4" ↔ 1/4"

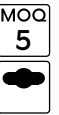

Č.p.	špecifikácia	
18619		5



Stahlberg

NADSTAVEC NA BITY



Č.p.	špecifikácia	
18600	1/4' x 60 mm	5



Stahlberg

NADSTAVEC NA BITY



Č.p.	špecifikácia	
18797	1/4' x 60 mm	1



Stahlberg

NADSTAVEC NA BITY

· rýchlopínací



Č.p.	špecifikácia	
18601	1/4' x 60 mm	5



Stahlberg

NADSTAVEC NA BITY

· rýchlopínací

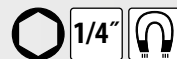

Č.p.	špecifikácia	
18798	1/4' x 60 mm	1



Stahlberg

NADSTAVEC NA BITY

· s dorazom



Č.p.	špecifikácia	
18602	1/4" x 60 mm	5



Stahlberg

NADSTAVEC NA BITY

· s dorazom



Č.p.	špecifikácia	
18799	1/4" x 60 mm	1

NEW



Stahlberg

NÁSTAVEC NA BITY



Č.p.	špecifikácia	
18605	150 mm	25

NEW



FESTA

ADAPTÉR SDS + NA BIT 1/4"



Č.p.	špecifikácia	
20743	75 mm	1



NADSTAVEC NA BITY



Č.p.	špecifikácia	
18607	80 mm	25



Stahlberg

ADAPTÉR 1/4"

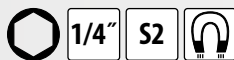

Č.p.	špecifikácia		Č.p.	špecifikácia	
18610	6 mm	5	18613	10 mm	5
18611	7 mm	5	18614	12 mm	5
18612	8 mm	5	18615	13 mm	5

ADAPTÉR - SADA

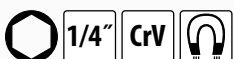

Č.p.	špecifikácia	
18618	6, 7, 8, 9, 10, 11, 12, 13 mm	





Stahlberg

SADA BITOV A ADAPTÉROV

- 10x ⊕ 18630 PH0
- 10x ⊕ 18631 PH1
- 10x ⊕ 18632 PH2
- 10x ⊕ 18633 PH3
- 10x ⊕ 18635 PZ0
- 10x ⊕ 18636 PZ1
- 10x ⊕ 18637 PZ2
- 10x ⊕ 18638 PZ3
- 10x ⊕ 18761 PH1 TiN
- 10x ⊕ 18762 PH2 TiN
- 10x ⊕ 18763 PH3 TiN
- 10x ⊕ 18766 PZ1 TiN
- 10x ⊕ 18767 PZ2 TiN
- 10x ⊕ 18768 PZ3 TiN
- 10x ⊕ 18770 PH1 DIAMANT
- 10x ⊕ 18771 PH2 DIAMANT
- 10x ⊕ 18775 PZ1 DIAMANT
- 10x ⊕ 18776 PZ2 DIAMANT
- 10x ⊙ 18814 4,0HTa
- 10x ⊙ 18815 5,0HTa
- 10x ⊕ 18842 20TTa
- 10x ⊕ 18845 30TTa
- 10x ⊕ 18795 PH2 na sadrokartón
- 5x 18612 adaptér 1/4" 8mm
- 5x 18613 adaptér 1/4" 10mm
- 5x 18600 magnetický nadstavec 1/4" 60mm
- 5x 18601 magnetický nadstavec, rychloupínací 1/4" 60mm
- 5x 18602 magnetický nadstavec, s dorazom 1/4" 65mm

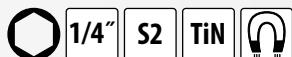

Č.p. špecifikácia

18993



1

Stahlberg

SADA BITOV

- 10x ⊕ 18631 PH1
- 10x ⊕ 18632 PH2
- 10x ⊕ 18633 PH3
- 10x ⊕ 18636 PZ1
- 10x ⊕ 18637 PZ2
- 10x ⊕ 18638 PZ3
- 10x ⊕ 18761 PH1 TiN
- 10x ⊕ 18762 PH2 TiN
- 10x ⊕ 18763 PH3 TiN
- 10x ⊕ 18766 PZ1 TiN
- 10x ⊕ 18767 PZ2 TiN
- 10x ⊕ 18768 PZ3 TiN
- 10x ⊙ 18804 H 4
- 10x ⊙ 18805 H 5
- 10x ⊕ 18825 T 10
- 10x ⊕ 18826 T 15
- 10x ⊕ 18827 T 20
- 10x ⊕ 18828 T 25
- 10x ⊕ 18830 T 30
- 10x ⊕ 18831 T 40

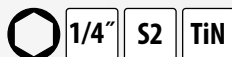

Č.p. špecifikácia

18994



1

FESTA

SADA BITOV



- ⊖ S 3 · 4 · 5 · 6
- ⊕ PH 1 · 2 · 3
- ✱ PZ 1 · 2 · 3
- H 3 · 4 · 5 · 6
- ⊛ T 10 · 15 · 20 · 25 · 27 · 30 · 40
- ⊛ TTa 10 · 15 · 20 · 25 · 27 · 30 · 40
· magnetický nadstavec
· rýchlopínací

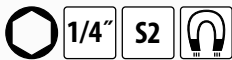

32x

Č.p. špecifikácia
18905



10

FESTA

SADA BITOV



- ⊖ S 4 · 5 · 6
- ⊕ PH 1 · 2 · 3
- ✱ PZ 1 · 2 · 3
- H 3 · 4 · 5 · 6
- ⊛ T 10 · 15 · 20 · 25 · 27 · 30 · 40
- ⊛ TTa 10 · 15 · 20 · 25 · 27 · 30 · 40
· magnetický nadstavec
· rýchlopínací

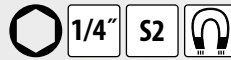

57x

Č.p. špecifikácia
18906



6

FESTA

SADA BITOV

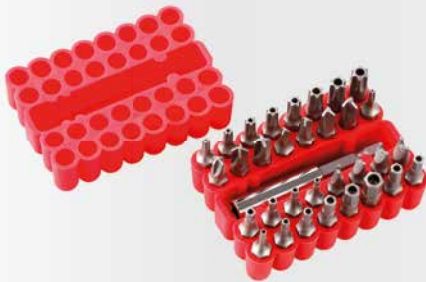

- ⊛ HTa 2 · 2.5 · 3 · 4 · 5 · 6
5/32" · 9/64" · 1/8"
7/64" · 3/32" · 5/64"
- ⊙ SD 4 · 6 · 8 · 10
- ⊕ TS 6 · 8 · 10
- ⊖ TW 1 · 2 · 3 · 4
- ⊛ TTa 8 · 10 · 15 · 20 · 25 · 27 · 30 · 35 · 40
· magnetický nadstavec

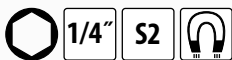

33x

Č.p. špecifikácia
18900



10

FESTA

SADA BITOV



- ⊖ S 3 · 4 · 4.5 · 5 · 5.5 · 6 · 6.5 · 7 · 8
- ⊕ PH 0 · 1 · 2 · 3
- ✱ PZ 0 · 1 · 2 · 3
- ⊖ SQ 0 · 1 · 2 · 3
- ⊛ T 8 · 10 · 15 · 20 · 25 · 27 · 30 · 40 · 45
- ⊛ TTa 8 · 10 · 15 · 20 · 25 · 27 · 30 · 35 · 40
- H 1.5 · 2 · 2.5 · 3 · 4 · 5 · 5.5 · 6 · 8 mm
1/16" · 5/64" · 3/32" · 7/64" · 1/8" · 9/64"
5/32" · 3/16" · 7/32" · 1/4"
- ⊛ HTa 2 · 2.5 · 3 · 4 · 5 · 6 mm
5/64" · 3/32" · 7/64" · 1/8" · 9/64" · 5/32"
- ⊙ SD 4 · 6 · 8 · 10
- ⊕ TS 6 · 8 · 10
- ⊖ TW 1 · 2 · 3 · 4
- ⊖ 2-wing 1 · 2 · 3
- ⊛ XZN 5 · 6 · 8
· magnetický nadstavec
· nadstavec „Y“
· 1/4" DR nadstavec na skrutkovač
· 1/4" bit adaptér: 25mm, 50mm

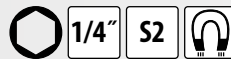

100x

Č.p. špecifikácia
18909



24

FESTA

SADA BITOV

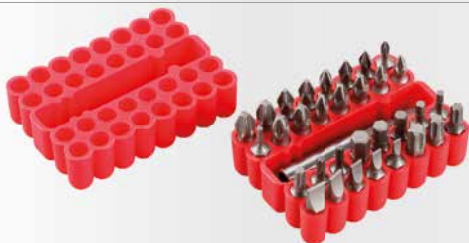

- ⊖ S 3 · 4 · 5 · 6 · 7
- ⊕ PH 0 · 1 · 2 · 3
- ✱ PZ 1 · 2 · 3
- H 2 · 2.5 · 3 · 4 · 5 · 6
- ⊛ T 10 · 15 · 20 · 25 · 30 · 40
· magnetický nadstavec

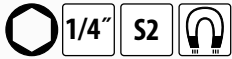

33x

Č.p. špecifikácia
18901



10



SADA BITOV

- ⊖ S 4 · 5 · 6 · 7
- ⊕ PH 1 · 2 · 3
- ✱ PZ 1 · 2 · 3
- H 4 · 5 · 6
- ★ T 10 · 15 · 20 · 25
- SQ 1 · 2 · 3

S2

20x



10

Č.p. špecifikácia

18907

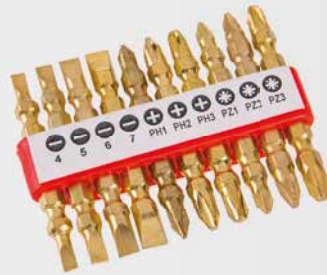

SADA BITOV

- ⊖ S 4 · 5 · 6 · 7
- ⊕ PH 1 · 2 · 3
- ✱ PZ 1 · 2 · 3

CrV TiN

10x



10

Č.p. špecifikácia

18440



SADA BITOV

- ⊖ S 3 · 5 · 7
 - ⊕ PH 1 · 2 · 3
- magnetický nastavtec na bity

HOBBY

7x



20

Č.p. špecifikácia

18430



SADA BITOV A NÁSTAVCOV

- ⊖ S 3 · 4 · 4,5 · 5 · 5,5 · 6 · 7
- ⊕ PH 1 · 2 · 3
- ✱ PZ 1 · 2 · 3
- H 2 · 3 · 4 · 5
- ★ T 20 · 30
- 1/4" 4 · 4,5 · 5 · 5,5 · 6 · 7 · 8 · 9 · 10
- 5/32" · 3/16" · 7/32" · 1/4" · 9/32" · 5/16" · 11/32" · 3/8" · 7/16"

magnetický skrutkovač
nastavec na bity
2 ks adaptér

1/4" CrV

41x



10

Č.p. špecifikácia

18916



SADA BITOV A NÁSTAVCOV

- ⊖ S 3 · 3,5 · 4 · 5,5
- ⊕ PH 0 · 1 · 2 · 3
- ✱ PZ 0 · 1 · 2 · 3
- H 3 · 4
- ★ T 10 · 15 · 20 · 25 · 27 · 30
- 1/4" 4 · 4,5 · 5 · 5,5 · 6 · 7 · 8 · 9 · 10 · 11 · 13

nastavec na skrutkovač 1/4"
magnetický nastavtec na bity

CrV 1/4"

40x



10

Č.p. špecifikácia

18915

SADA NÁRADIA

- ⊖ S 5 · 6 mm
- ⊕ PH 1 · 2
- H 3 · 4 · 5 · 6
- ★ T 15 · 20 · 25 · 30
- 1/4" 4 · 5 · 6 · 7 · 8 · 9 · 10 · 12 · 13 mm

75 mm 1/4" 1/4" 1/4"

1/4" CrV

23x















10

Č.p. špecifikácia

18421



SADA NÁRADIA

-  120mm
-  125mm
-  115mm
-  150mm max. 19mm
-  9mm
-  1/4" 160mm
-  5 · 6 · 7 · 8 · 9 · 10 · 11 mm
-  1/4"
-  1/4"
-  S 4 · 6 mm
-  PH 1 · 2 · 3
-  PZ 1 · 2
-  H 4 · 5 · 6

35x











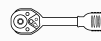

















Č.p. 17260
špecifikácia

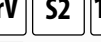

10

FESTA

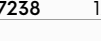
SADA NÁRADIA

-  1/2", 1/4"
-  1/4" · 4-5-6-7-8-9mm
-  1/2" · 10-12-13-14-17-19mm
-  1/4" · 4-4.5-5-5.5-6-7-8-9-10-11-12-13-14mm
-  1/2" · 12-13-14-15-16-17-18-19-20-21-22-24mm
-  1/2", 1/4"
-  1/4" → ●/4"
-  1/4" · 150mm
-  1/2" · 254mm
-  1/2", 1/4"
-  1/2" · 16-21mm
-  1/4" · 150mm
-  1/2" · E10-E12-E14-E16-E18-E20-E22-E24
-  1/4" · S 3 · 4 · 5 · 6
-  1/4" · PH 0 · 1 · 2
-  1/4" · PZ 0 · 1 · 2
-  1/4" · S 4 · 5,5 · 6,5
-  1/4" · PH 1 · 2 · 3
-  1/4" · PZ 2 · 3
-  1/4" · H 3 · 4 · 5 · 6
-  1/4" · T 8 · 10 · 15 · 20 · 25
-  1/4" · TTα 10 · 15 · 20 · 25 · 40
-  ● 2 · 2,5 · 3 · 4 · 5 · 6 · 7 · 8 · 10mm
-  8-9-10-11-12-13-14-15-16-17-18-19mm
-  S 4x100 · 6,5x150
-  PH 2x100 · 3x150
-  180mm
-  160mm
-  160mm
-  250mm
- 300g

CrV S2 1/4" 1/2" 72T

122x

Č.p. 17238
špecifikácia 122 ks



1

SADA NÁRADIA

- 160 mm
- 160 mm
- 300 g
- 1/4" 45T
- 4 · 5 · 6 · 7 · 8 · 9 · 10 · 11 · 12 · 13 mm
- 1/4" 75 mm
- 1,5 · 2 · 2,5 · 3 · 4 · 5 · 6 · 8 · 10 mm
- S 3 · 4 · 5 · 6 mm
- PH 0 · 1 · 2 · 3
- PZ 0 · 1 · 2 · 3
- T 10 · 15 · 20 · 25
- H 3 · 4 · 5 · 6
- S 5x100 mm
- PH 1x100 · 2x100 mm
- S 2,5x50 mm
- PH 00x50 · 0x50 mm
- AC 100-250 V
- 200 mm max. 22 mm
- 10x11 · 12x13 · 14x15 · 16x17 mm
- 18 mm
- 2 m 13 mm



60x

Č.p. špecifikácia

17259



5

SADA NÁRADIA

- 1/4" 5 · 6 · 7 · 8 · 9 · 10 · 11 · 12 mm
- 1/4"
- 1/4"
- AC 230 V
- PH 0, SL 3
- 9x 1,5-10 mm
- 160 mm
- S 3 · 4 · 5 · 6 mm
- PH 0 · 1 · 2 · 3
- H 4 · 5
- PH 2x100, S 6x100
- 18 mm
- 1 m
- 300 g



32x

Č.p. špecifikácia

17247



10

FESTA

SADA INBUS

- H 1,5 mm
- H 2 mm
- H 2,5 mm
- H 3 mm
- H 4 mm
- H 5 mm
- H 6 mm
- H 8 mm
- H 10 mm



9x



Č.p. 18496 špecifikácia

FESTA

SADA INBUSOV S HLAVIČKOU

- H 1,5 mm
- H 2 mm
- H 2,5 mm
- H 3 mm
- H 4 mm
- H 5 mm
- H 6 mm
- H 8 mm
- H 10 mm



9x



Č.p. 18500 špecifikácia

FESTA

SADA INBUS - PREDĹŽENÉ

- H 1,5 mm
- H 2 mm
- H 2,5 mm
- H 3 mm
- H 4 mm
- H 5 mm
- H 6 mm
- H 8 mm
- H 10 mm



9x

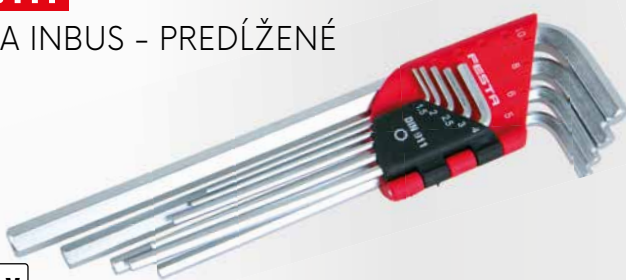

Č.p. 18490 špecifikácia

FESTA

SADA INBUSŮ S HLAVIČKOU

- H 1,5 mm
- H 2 mm
- H 2,5 mm
- H 3 mm
- H 4 mm
- H 5 mm
- H 6 mm
- H 8 mm
- H 10 mm



9x



Č.p. 18498 špecifikácia

FESTA

SADA INBUS S HLAVIČKOU

- 1/16"
- 5/64"
- 3/32"
- 1/8"
- 5/32"
- 3/16"
- 1/4"
- 5/16"
- 3/8"



9x



Č.p. 18493 špecifikácia

FESTA

SADA KLÚČOV TORX

- T 10 mm
- T 15 mm
- T 20 mm
- T 25 mm
- T 27 mm
- T 30 mm
- T 40 mm
- T 45 mm
- T 50 mm



9x



Č.p. 18497 špecifikácia

FESTA

SADA INBUS S HLAVIČKOU - PREDĹŽENÉ

- H 1,5 mm
- H 2 mm
- H 2,5 mm
- H 3 mm
- H 4 mm
- H 5 mm
- H 6 mm
- H 8 mm
- H 10 mm



9x



Č.p. 18492 špecifikácia

FESTA

SADA KLÚČOV TORX - PREDĹŽENÉ

- T 10 mm
- T 15 mm
- T 20 mm
- T 25 mm
- T 27 mm
- T 30 mm
- T 40 mm
- T 45 mm
- T 50 mm



9x



Č.p. 18491 špecifikácia



FESTA

KLÚČ INBUS - STANDARD



Č.p.	špecifikácia		
18548	8 mm	36 x 100 mm	1
18559	19 mm	70 x 180 mm	1
18562	22 mm	80 x 200 mm	1
18567	27 mm	100 x 250 mm	1
18572	32 mm	125 x 315 mm	1



FESTA

KLÚČ INBUS S HLAVIČKOU - PREDLŽENÝ



Č.p.	špecifikácia		
18575	1,5 mm	15 x 75 mm	1
18576	2 mm	17 x 81 mm	1
18577	2,5 mm	18 x 87 mm	1
18578	3 mm	20 x 96 mm	1
18579	4 mm	24 x 107 mm	1
18580	5 mm	30 x 120 mm	1
18581	6 mm	33 x 136 mm	1
18582	7 mm	34 x 144 mm	1
18583	8 mm	36 x 153 mm	1
18584	9 mm	38 x 155 mm	1
18585	10 mm	40 x 171 mm	1
18586	11 mm	40 x 230 mm	1
18587	12 mm	42 x 250 mm	1
18588	13 mm	45 x 260 mm	1
18589	14 mm	56 x 280 mm	1
18593	17 mm	61 x 290 mm	1



FESTA

KLÚČ INBUS - PREDLŽENÝ



Č.p.	špecifikácia		
18510	1,5 mm	15 x 75 mm	1
18511	2 mm	17 x 81 mm	1
18512	2,5 mm	18 x 87 mm	1
18513	3 mm	20 x 96 mm	1
18514	4 mm	24 x 107 mm	1
18515	5 mm	30 x 120 mm	1
18516	6 mm	33 x 136 mm	1
18518	8 mm	36 x 153 mm	1
18519	9 mm	38 x 155 mm	1
18520	10 mm	40 x 171 mm	1
18521	11 mm	40 x 230 mm	1
18522	12 mm	42 x 250 mm	1
18523	13 mm	45 x 260 mm	1
18524	14 mm	56 x 280 mm	1
18527	17 mm	61 x 290 mm	1



FESTA

KLÚČ TORX



Č.p.	špecifikácia	
18466	T7	1
18468	T9	1
18476	T45	1
18477	T50	1



FESTA

SADA INBUS



Č.p.	špecifikácia	
18508	1,5 · 2 · 2,5 · 3 · 4 · 5 · 6 mm	1



FESTA

NÁSTRČNÝ T - KLÚČ INBUS SADA

- 2 mm
- 2,5 mm
- 3 mm
- 4 mm
- 5 mm
- 6 mm
- 7 mm
- 8 mm
- 10 mm



9x



Č.p.	špecifikácia	
18494		6



FESTA

NÁSTRČNÝ T - KLÚČ TORX SADA

- T 10
- T 15
- T 20
- T 25
- T 27
- T 30
- T 40
- T 45
- T 50



9x



Č.p.	špecifikácia	
18495		6



SADA INBUS



8x



Č.p.	špecifikácia	
18499	2 · 2,5 · 3 · 4 · 5 · 6 · 8 · 10 mm	1



FESTA

KLÚČ NÁSTRČNÝ T - TORX



Č.p.	špecifikácia		Č.p.	špecifikácia	
17350	T 7	10	17357	T 27	10
17351	T 8	10	17359	T 40	10
17352	T 9	10	17360	T 45	10
17353	T 10	10	17361	T 50	10

FESTA®



KLADIVÁ A ŠŪĽKY



FESTA®

KLADIVO

· jaseňová násada

DIN 1041

Č.p.	špecifikácia	
19081	100 g	1
19082	200 g	1
19083	300 g	1
19084	400 g	1
19085	500 g	1
19086	600 g	1
19088	800 g	1
19090	1000 g	1
19092	1500 g	1
19095	2000 g	1



FESTA®

ŠŪĽKA

· jaseňová násada

DIN 1041

Č.p.	špecifikácia	
19096	3000 g	1
19097	4000 g	1
19098	5000 g	1
19106	6000 g	1
19108	8000 g	1
19109	10000 g	1

NEW



FESTA®

ŠŪĽKA

· jaseňová násada

DIN 6475

Č.p.	špecifikácia	
19041	1000 g	1
19042	1250 g	1
19043	1500 g	1
19044	2000 g	1



FESTA®

ŠŪĽKA

· jaseňová násada

DIN 6475

Č.p.	špecifikácia	
19045 NEW	3000 g	1
19046 NEW	4000 g	1
19074	5000 g	1
19075	6000 g	1
19076	8000 g	1
19077	10000 g	1

**FESTA****KLADIVO FIBERGLASS**

· násada fiberglass

Č.p.	špecifikácia		Č.p.	špecifikácia	
19021	100 g	12	19026	600 g	6
19022	200 g	12	19028	800 g	6
19023	300 g	12	19030	1000 g	6
19024	400 g	12	19031	1500 g	6
19025	500 g	12	19032	2000 g	1

**FESTA****ŠŪLKA FIBERGLASS**

· násada fiberglass

DIN 6475

Č.p.	špecifikácia	
19066	1000 g	4
19067	1250 g	4
19068	1500 g	4
19069	2000 g	2

**KLADIVO**

· kruhový klin

DIN 1041

Č.p.	špecifikácia	
19001	100 g	12
19002	200 g	12
19003	300 g	6
19004	400 g	6
19005	500 g	6
19006	600 g	6
19008	800 g	6
19010	1000 g	6
19015	1500 g	6
19020	2000 g	6

**FESTA****ŠŪLKA FIBERGLASS**

· násada fiberglass

Č.p.	špecifikácia	
19034	3000 g	4
19036	4000 g	4

**FESTA****ŠŪLKA FIBERGLASS**

· násada fiberglass

Č.p.	špecifikácia	
19070	3000 g	4
19071	4000 g	4
19058	5000 g	4
19059	6000 g	2

**ŠŪLKA**

· kruhový klin

DIN 6475

Č.p.	špecifikácia	
19053	1000 g	6
19050	1250 g	6
19054	1500 g	6
19055	2000 g	6

**ŠŪLKA**

· kruhový klin

DIN 6475

Č.p.	špecifikácia	
19056	3000 g	6
19057	4000 g	6



FESTA

KLADIVO OBUVNÍCKE FIBERGLASS

· násada fiberglass

Č.p.	špecifikácia	
19064	450 g	6



FESTA

KLADIVO TESÁRSKE FIBERGLASS

· násada fiberglass



Č.p.	špecifikácia	
19061	600 g	6



FESTA

KLADIVO MURÁRSKE FIBERGLASS

· násada fiberglass

Č.p.	špecifikácia	
19151	600 g	6



FESTA

KLADIVO OBUVNÍCKE MONOLIT

Č.p.	špecifikácia	
19063	450 g	6



FESTA

KLADIVO TESÁRSKE MONOLIT



Č.p.	špecifikácia	
19062	600 g	6



FESTA

KLADIVO MURÁRSKE MONOLIT

Č.p.	špecifikácia	
19150	600 g	6



KLADIVO TESÁRSKE



Č.p.	špecifikácia	
19100	600 g	6

**FESTA**

KLADIVO OBUVNÍČKE

Č.p.	špecifikácia	
19065	600 g	6

**FESTA**

KLADIVO TESÁRSKE



Č.p.	špecifikácia	
19060	600 g	6

**FESTA**

ŠŮLKA

Č.p.	špecifikácia	
19051	1000 g	6
19052	1500 g	6

**FESTA**

KLADIVO - SEKERA

Č.p.	špecifikácia	
19303	600 g	6

**FESTA**

KLADIVO MURÁRSKE

jaseňová násada

Č.p.	špecifikácia	
19149	44 mm	1

**FESTA**

KLADIVO MURÁRSKE

jaseňová násada

Č.p.	špecifikácia	
19124	24 mm	1
19136	36 mm	1
19148	48 mm	1



KLADIVO ZVÁRAČSKÉ



Č.p.	špecifikácia	
19115	300 g	1

**FESTA**

NÁSADA NA KLADIVO JASEŇOVÁ

Č.p.	špecifikácia	
61240	násada	1



NÁSADA NA KLADIVO JASEŇOVÁ



Č.p.	špecifikácia	pre kladivo	
61320	26 cm	19081	10
61321	28 cm	19082	10
61322	30 cm	19083	10
61323	31 cm	19084	10
61324	32 cm	19085	10



NÁSADA ŠŮLKY JASEŇOVÁ



Č.p.	špecifikácia	pre palice	
61330	80 cm	19074, 19075	10
61331	90 cm	19076, 19077	10



KLIN KRUHOVÝ KÓNICKÝ

Č.p.	špecifikácia	
19430	6 mm	10
19431	8 mm	10
19432	10 mm	10
19433	12 mm	10
19434	14 mm	10
19435	16 mm	10



KLIN KOVANÝ



Č.p.	špecifikácia	
19440	úzký	10
19441	střední	10
19442	široký	10
19443	široký S	10



FESTA

KLIN



Č.p.	špecifikácia	
19398	20 x 25 x 5 mm	1
19399	30 x 40 x 5 mm	1

3x

**FESTA****ŠŮLKA DREVENÁ**

· bukové drevo



Č.p.	špecifikácia		
19202	Ø 60 x 120 mm	350 g	1

**FESTA****ŠŮLKA DREVENÁ**

· bukové drevo



Č.p.	špecifikácia		
19200	80 x 60 mm	520 g	1

**FESTA****ŠŮLKA GUMOVÁ**

· jaseňová násada



Č.p.	špecifikácia		
19245	Ø 55 mm	400 g	1
19246	Ø 60 mm	800 g	1
19247	Ø 70 mm	1000 g	1
19248	Ø 95 mm	2000 g	1
19249	Ø 115 mm	3000 g	1

**FESTA****ŠŮLKA GUMOVÁ**

· násada fiberglass



Č.p.	špecifikácia		
19270	Ø 55 mm		6
19271	Ø 65 mm		6
19272	Ø 90 mm		6

**FESTA****ŠŮLKA GUMOVÁ**

Č.p.	špecifikácia		
19255	Ø 55 mm		6
19265	Ø 65 mm		6
19290	Ø 90 mm		6

**FESTA****ŠŮLKA GUMOVÁ BIELA**

Č.p.	špecifikácia		
19293	NEW Ø 55 mm		6
19294	Ø 65 mm		6
19295	Ø 90 mm		6



Č.p.	špecifikácia		
19254	Ø 65 mm		6



ŠŮLKA GUMOVÁ



Č.p.	špecifikácia	
19251	Ø 55 mm 400 g	12
19252	Ø 65 mm 700 g	6
19253	Ø 90 mm 1300 g	4



ŠŮLKA MOSADZNÁ

· násada fiberglass

Č.p.	špecifikácia	
19211	Ø 30 mm 500 g	1



ŠŮLKA SILIKÓNOVÁ

Č.p.	špecifikácia	
19297	Ø 35 mm	12



ŠŮLKA NYLONOVÁ

· násada fiberglass



Č.p.	špecifikácia	
19209	Ø 34 mm	6



PALIČKA S VÝMENNÝMI KONCAMI

· PP - 97 Shore A



· TPE - 90 Shore A



· TPU - 92 Shore A



· TPU - 88 Shore A



· TPU - 95 Shore A



· TPE - 90 Shore A



· TPU - 92 Shore A



· TPE - 90 Shore A



Č.p.	špecifikácia	
19208	Ø 40 mm	1

FESTA®

SEKERY



FESTA®

SEKERA TESÁRSKA

DIN 5131

DIN 7294

- jaseňová násada
- kruhový klin

Č.p.	špecifikácia		Č.p.	špecifikácia	
19380	600 g	1	19384	1400 g	1
19381	800 g	1	19385	1600 g	1
19382	1000 g	1	19387	2000 g	1
19383	1250 g	1			



FESTA®

SEKERA ŠTIEPACIA

- jaseňová násada

Č.p.	špecifikácia	
19340	700 g	22



FESTA®

SEKERA ŠTIEPACIA

- jaseňová násada
- kruhový klin

DIN 7294

Č.p.	špecifikácia	
19391	2000 g	1

FESTA®

KALAČ

- jaseňová násada
- kruhový klin

DIN 5129

Č.p.	špecifikácia	
19389	3000 g	1
19388	4000 g	1



SEKERA

Č.p.	špecifikácia	
19306	600 g	24
19308	800 g	24
19310	1000 g	24
19312	1250 g	12
19314	1500 g	12



NÁSADA NA SEKERU JASEŇOVÁ



Č.p.	špecifikácia	pro kladivo	
61340	36 cm	19380	10
61341	40 cm	19381, 19340	10
61342	50 cm	19382	10
61343	70 cm	19383, 19384	10

Č.p.	špecifikácia	pro kladivo	
61344	80 cm	19385, 19391	10
61345	90 cm	19387	10
61346	90 cm	19388, 19389	10



FESTA

SEKERA FIBERGLASS

· násada fiberglass

Č.p.	špecifikácia	
19326	600 g	6
19328	800 g	24
19330	1000 g	12

Č.p.	špecifikácia	
19332	1250 g	8
19333	1500 g	6
19335	1600 g	6
19337	2000 g	6



FESTA

SEKERA CAMP FIBERGLASS

· násada fiberglass

Č.p.	špecifikácia	
19301	500 g	6



FESTA

SEKERA ŠTIEPACIA FIBERGLASS

· násada fiberglass

Č.p.	špecifikácia	
19392	1000 g	6



FESTA

SEKERA ŠTIEPACIA FIBERGLASS

· násada fiberglass

Č.p.	špecifikácia	
19390	2000 g	6



FESTA

KALAČ FIBERGLASS

· násada fiberglass

Č.p.	špecifikácia	
19370	3000 g	4
19371	4000 g	4



Black Eagle

SEKERA



Č.p.	špecifikácia	
19356	1200 g	5
19357	1800 g	1



ŠTIEPACÍ TRŇ SDS+



Č.p.	špecifikácia	
19393	Ø 32 x 132 mm	10
19374	Ø 42 x 145 mm	10



KLIN ŠTIEPACÍ TORZNÝ

Č.p.	špecifikácia	
19397	2000 g 55 x 210 x 45 mm	10
19465	2500 g 65 x 230 x 45 mm	10



KLIN ŠTIEPACÍ ŠTVORRAMENNÝ

Č.p.	špecifikácia	
19469	2500 g 165 x 87 mm	10



KLIN NYLONOVÝ



Č.p.	špecifikácia	
19462	175 x 65 x 20 mm	1
19463	230 x 70 x 30 mm	1
19464	240 x 75 x 40 mm	1



KLIN ŠTIEPACÍ

Č.p.	špecifikácia	
19394	1000 g 35 x 180 x 40 mm	6
19395	2000 g 40 x 255 x 55 mm	6
19396	2500 g 40 x 260 x 55 mm	8



FESTO
PÁČIDLO



Č.p.	špecifikácia	
19424	400 mm	6
19425	600 mm	6
19426	800 mm	6
19427	1000 mm	6



PÁČIDLO

Č.p.	špecifikácia	
19416	600 mm Ø 16 mm	4
19422	800 mm Ø 16 mm	4
19421	1000 mm Ø 18 mm	4



VYŤAHOVÁK PÁČIDLO

Č.p.	špecifikácia	
19423	380 x 35 x 6 mm	1



VYŤAHOVÁK PÁČIDLO

Č.p.	špecifikácia	
19415	300 mm Ø 15 mm	6

**FESTA**

SEKÁČ PLOCHÝ

CrV

Č.p.	špecifikácia	šírka hrotu	
19406	300 mm	25 mm	5
19407	400 mm	30 mm	5

**FESTA**

SEKÁČ ŠPICATÝ

CrV

Č.p.	špecifikácia	
19408	250 mm	5
19409	350 mm	5

**FESTA**

SEKÁČ PLOCHÝ

CrV

Č.p.	špecifikácia	šírka hrotu	
19460	300 mm	25 mm	5
19470	400 mm	30 mm	5



SEKÁČ ŠPICATÝ

Č.p.	špecifikácia	
19400	250 mm	5
19403	350 mm	6



SEKÁČ PLOCHÝ

Č.p.	špecifikácia	šírka hrotu	
19401	250 mm	19 mm	6
19404	350 mm	22 mm	6



SEKÁČ PLOCHÝ

Č.p.	špecifikácia	šírka hrotu	
19402	250 mm	50 mm	2
19405	350 mm	50 mm	6

**FESTA**

SEKÁČ PLOCHÝ

CrV

Č.p.	špecifikácia	šírka hrotu	
19410	200 mm	20 mm	10
19411	250 mm	25 mm	10
19412	300 mm	25 mm	10
19418	400 mm	25 mm	5
19419	500 mm	25 mm	5



SEKÁČ ZÁMOČNÍCKY PLOCHÝ

CrV

Č.p.	špecifikácia	šírka hrotu	
19436	200 mm	20 mm	15



DLÁTA

FESTA®



FESTA®

DLÁTO

CrV



Č.p.	špecifikácia		Č.p.	špecifikácia	
19490	6 mm 275 mm	6	19496	18 mm 280 mm	6
19491	8 mm 275 mm	6	19497	20 mm 280 mm	6
19492	10 mm 275 mm	6	19498	22 mm 280 mm	6
19493	12 mm 275 mm	6	19499	25 mm 280 mm	6
19494	14 mm 275 mm	6	19501	32 mm 290 mm	6
19495	16 mm 275 mm	6	19502	38 mm 290 mm	6

SADA DLÁT



4x

Č.p.	špecifikácia	
19450		20

FESTA®

SADA DLÁT S BRÚSIKOM

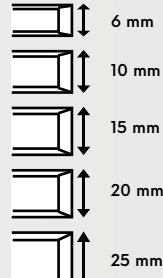

CrV 5x



Č.p.	špecifikácia	
19451		10

FESTA®

SADA DLÁT



CrV 4x



Č.p.	špecifikácia	
19457		10



FESTA®

DLÁTO STOLÁRSKE MULTIFUNKČNÉ

INOX



Č.p.	špecifikácia	
16231	20 80 mm	12

SADA DLÁT



4x

Č.p.	špecifikácia	
19455		30



FESTA

SADA SÚSTRUŽNÍCKYCH DLÁT

CrV

8x



Č.p.	špecifikácia	
19458	365 125mm	1



SADA REZBÁRSKYCH DLÁT

CrV

12x



Č.p.	špecifikácia	
19459		5



HOBLÍK KLOPKÁR



Č.p.	špecifikácia	
19510	220 x 65 x 130 mm, nůž 48 mm	1



HOBLÍK - HLADÍK



Č.p.	špecifikácia	
19515	200 x 55 x 130 mm, nůž 39 mm	1



HOBLÍK RÍMSOVNÍK



Č.p.	špecifikácia	
19520	225 x 27 x 155 mm, nůž 27 mm	1



SADA KLAMPIARSKA

7x

Č.p.	špecifikácia	
19110		5



5





FESTA®



SPONKOVAČKY







FESTA®
SPONKOVAČKA 5 V 1

-  | 6 - 14 mm
23960 - 23964
23760 - 23764,
23906 - 23914
-  | 10 - 14 mm
23965
-  | 15 mm
23966
-  | 15 mm
23967

Č.p. špecifikácia 
23927 6



FESTA®
SPONKOVAČKA
4 V 1

-  | 6 - 14 mm
23960 - 23964
-  | 12 mm
23965
-  | 14 mm
23966
-  | 14 mm
23967



Č.p. špecifikácia 
23924 12

FESTA®
SPONKOVAČKA
3 V 1

-  | 6 - 14 mm
23960 - 23964
-  | 14 mm
23966
-  | 14 mm
23967



Č.p. špecifikácia 
23923 12

FESTA®
SPONKOVAČKA

-  53 | 4 - 14 mm
23904 - 23914,
23760 - 23765



Č.p. špecifikácia 
23925 4 - 14 mm s aretáciou 20

FESTA®
ODSTRAŇOVAČ SPON



Č.p. špecifikácia 
23945 25

SPONKOVAČKA

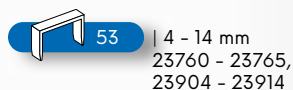

Č.p.	špecifikácia	
23800		20

SPONKOVAČKA

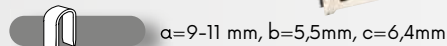
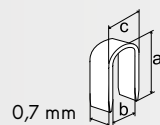

Č.p.	špecifikácia	
23920		4

FESTA

KLADIVO SPONKOVACIE



Č.p.	špecifikácia	
23922		10

KLADIVO SPONKOVACIE



Č.p.	špecifikácia	
23928		6

FESTA

SPONY EXTRA

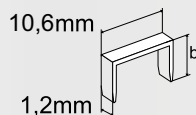

Č.p.	špecifikácia	
23960	b=6 mm, 1000 ks	50
23961	b=8 mm, 1000 ks	50
23962	b=10 mm, 1000 ks	50
23963	b=12 mm, 1000 ks	50
23964	b=14 mm, 1000 ks	50

SPONY - TYP 53

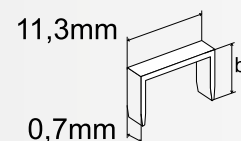
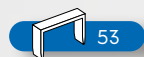

Č.p.	špecifikácia	
23904	b=4 mm 1000 ks	200
23906	b=6 mm 1000 ks	200
23908	b=8 mm 1000 ks	200
23910	b=10 mm 1000 ks	200
23912	b=12 mm 1000 ks	200
23914	b=14 mm 1000 ks	200

FESTA

SPONY

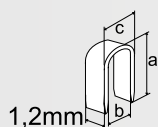

Č.p.	špecifikácia	
23965	a=12 mm, b=6,5 mm, c=7,5 mm, 1000 TW	50

FESTA

KLINCE



Č.p.	špecifikácia	
23966	klince 14 mm 1000 TW	100

SPONY - TYP 53

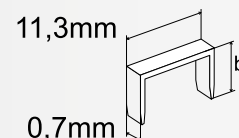

Č.p.	špecifikácia	
23760	b=4 mm 2000 ks	10
23761	b=6 mm 2000 ks	10
23762	b=8 mm 2000 ks	10
23763	b=10 mm 2000 ks	10
23764	b=12 mm 2000 ks	10

FESTA

KLINCE



Č.p.	špecifikácia	
23967	klince 14 mm 1000 TW	100



SVORKY A ZVERÁKY



FESTA

SVORKA RÝCHLOUPÍNACIA

· kovaná



Č.p.	špecifikácia	
23560	200 x 80 mm	1
23561	300 x 100 mm	1
23562	400 x 100 mm	1
23563	500 x 120 mm	1

Č.p.	špecifikácia	
23564	600 x 120 mm	1
23565	800 x 120 mm	1
23566	1000 x 120 mm	1

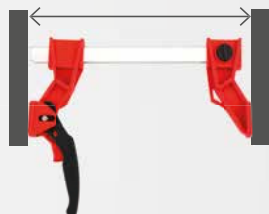

FESTA

SVORKA RÝCHLOUPÍNACIA



Č.p.	špecifikácia	
23570	100 x 80 mm	1
23571	160 x 80 mm	1
23572	200 x 80 mm	1
23573	250 x 80 mm	1
23574	300 x 80 mm	1

FESTA

SVORKA STOLÁRSKA



Č.p.	špecifikácia		Č.p.	špecifikácia		Č.p.	špecifikácia	
23670	150 x 105 mm	1	23676	500 x 175 mm	1	23682	1500 x 175 mm	1
23671	200 x 105 mm	1	23677	600 x 175 mm	1	23683	1750 x 175 mm	1
23672	250 x 105 mm	1	23678	700 x 175 mm	1	23684	2000 x 175 mm	1
23673	300 x 105 mm	1	23679	800 x 175 mm	1	23685	2200 x 175 mm	1
23674	350 x 105 mm	1	23680	1000 x 175 mm	1			
23675	400 x 175 mm	1	23681	1250 x 175 mm	1			



SVORKA

DIN
5117

Č.p.	špecifikácia	
23506	300 x 120 mm	10
23507	500 x 120 mm	10
23508	800 x 120 mm	6

SVORKA

Č.p.	špecifikácia	
23515	150 x 50 mm	50
23520	200 x 50 mm	50
23525	250 x 50 mm	50
23530	300 x 50 mm	50
23531	300 x 120 mm	20
23551	500 x 120 mm	10



FESTO

SVORKA RÝCHLOUPÍNACIA

Č.p.	špecifikácia	
23625	200 mm	6
23626	300 mm	6
23628	450 mm	6
23630	600 mm	6
23632	760 mm	6

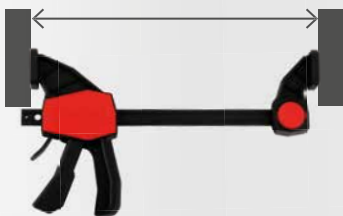

FESTO

SVORKA RÝCHLOUPÍNACIA

Č.p.	špecifikácia	
23585	150 mm	6
23587	300 mm	6
23589	450 mm	6
23591	600 mm	6

SVORKA SO ZUBOVOU
POISTKOU

rozteč 80 mm | span 80 mm

Č.p.	špecifikácia	
23605	9' 230 mm	6

SVORKA PLASTOVÁ

Č.p.	špecifikácia	
23600	4', rozteč 40 mm	20
23601	6', rozteč 50 mm	12
23602	9', rozteč 80 mm	20

'G' SVORKY SADA

3x

Č.p.	špecifikácia	
23620	25 mm, 50 mm, 75 mm	10



FESTA

ZVERÁK

· tvrdené čeluste

Č.p.	špecifikácia	
23410	100 mm	1
23411	125 mm	1
23412	150 mm	1



ZVERÁK OTOČNÝ

· tvrdené čeluste

Č.p.	špecifikácia	
23415	100 mm	1
23416	125 mm	1
23417	150 mm	1



ZVERÁK OTOČNÝ

Č.p.	špecifikácia	
23407	65 mm	10



ZVERÁK POD VŔTAČKU

· tvrdené čeluste

Č.p.	špecifikácia	
23400	18 80 mm	10
23401	22 100 mm	10
23402	24 125 mm	5



SVORKA ROHOVÁ 90°

ALU

· rozsah 0 - 65 mm

Č.p.	špecifikácia	
23420	65 mm	20



**ZVERÁK MODELÁRSKY OTOČNÝ 360°
STOLNÝ**

ALU

Č.p.	špecifikácia	
23406	80 mm	24



NEW



STÔL PRACOVNÝ SKLADACIE

· max. 100 kg

Č.p.	špecifikácia
23655	100 x 50 x 84 cm



1



STÔL PRACOVNÝ

· ideálny do pivničných kójí

Č.p.	špecifikácia
23660	



1

STÔL PRACOVNÝ MULTIFUNKČNÝ

Č.p.	špecifikácia
23650	



1

NEW



FESTA

KOZA SKLADACIA

· maximální nosnosť: 590 kg

Č.p. Špecifikácia

23657



1

NEW



FESTA

PRENOSNÝ STOJANOVÝ ZVERÁK

· rozsah čelustí: 0 - 95 cm

· maximální nosnosť: 250 kg

Č.p. Špecifikácia

37553



1

FESTA®

KLIŠTE NITOVACIE



FESTA® KLIŠTE NITOVACIE

Cr-Mo

Ø 2,4 mm
Ø 3,2 mm
Ø 4,0 mm
Ø 4,8 mm



Č.p. 24007 špecifikácia 200 mm



FESTA® KLIŠTE NITOVACIE

Cr-Mo

Ø 2,4 mm
Ø 3,2 mm
Ø 4,0 mm
Ø 4,8 mm



Č.p. 24010 špecifikácia 250 mm



FESTA

KLIEŠTE NITOVACIE

Cr-Mo

- Ø 2,4 mm
- Ø 3,2 mm
- Ø 4,0 mm
- Ø 4,8 mm
- Ø 6,4 mm



Č.p. 24017
špecifikácia 280 mm

1



FESTA

KLIEŠTE NITOVACIE

Cr-Mo

- Ø 2,4 mm
- Ø 3,2 mm
- Ø 4,0 mm
- Ø 4,8 mm
- Ø 6,4 mm



Č.p. 24015
špecifikácia 530 mm

1



FESTA

KLIEŠTE NITOVACIE

Cr-Mo

- Ø 2,4 mm
- Ø 3,0 mm
- Ø 3,2 mm
- Ø 4,0 mm
- Ø 4,8 mm



Č.p. 24030
špecifikácia 260 mm

24



FESTA

KLIEŠTE NITOVACIE

nastavitelná hlava klieští
2 pozície

Cr-Mo



Č.p. 24002
špecifikácia 260 mm

6

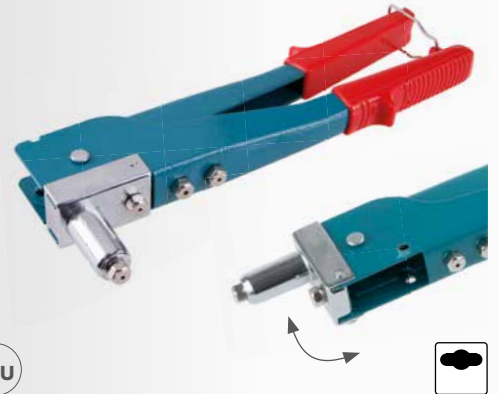

FESTA

KLIEŠTE NITOVACIE

Cr-Mo

- Ø 2,4 mm
- Ø 3,2 mm
- Ø 4,0 mm
- Ø 4,8 mm



Č.p. 24006
špecifikácia 250 mm

12



KLIEŠTE NITOVACIE + NITY

Cr-Mo

- Ø 2,4 x 6 mm
- Ø 3,2 x 6 mm
- Ø 4,0 x 6 mm
- Ø 4,8 x 6 mm



Č.p. 24005
špecifikácia 260 mm

5



FESTA

KLIEŠTE NITOVACIE S
OTOČNOU HLAVOU

Cr-Mo



Č.p. 24020
špecifikácia 290 mm

8



KLIEŠTE NITOVACIE PEVNÉ



Č.p. 24001
špecifikácia 260 mm

6



KLIEŠTE NITOVACIE



Č.p. 24000
špecifikácia 250 mm

24

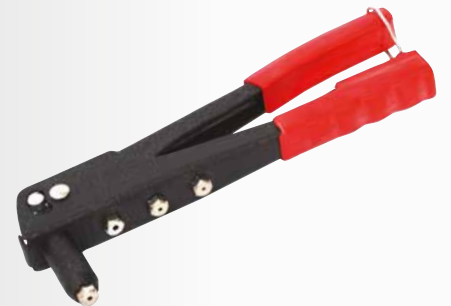

FESTA

KLIŠTE NITOVACIE PRE NITOVACIE MATICE

Cr-Mo

- M3
- M4
- M5
- M6
- M8
- M10



Č.p.	špecifikácia
24036	330 mm



1

FESTA

KLIŠTE NITOVACIE PRE NITOVACIE MATICE

Cr-Mo

- M3
- M4
- M5
- M6



Č.p.	špecifikácia
24035	200 mm



1

FESTA

HLAVICE DO NITOVACÍCH KLIŠTÍ PRE NITOVACIE MATICE

· vhodné pre 24035, 24036

Cr-Mo



Č.p.	špecifikácia	
24038	M3	1
24039	M4	1
24040	M5	1
24041	M6	1
24042	M8	1
24043	M10	1



NITY HLINÍKOVÉ TRHACIE

ALU

50x



Č.p.	špecifikácia	
23970	3,2 x 6 mm	25
23971	3,2 x 8 mm	25
23972	3,2 x 10 mm	25
23973	3,2 x 12 mm	25
23974	3,2 x 14 mm	25
23975	4,0 x 6 mm	25
23976	4,0 x 8 mm	25
23977	4,0 x 10 mm	25
23978	4,0 x 12 mm	25
23979	4,0 x 14 mm	25
23985	4,8 x 6 mm	25
23986	4,8 x 8 mm	25
23987	4,8 x 10 mm	25
23988	4,8 x 12 mm	25
23989	4,8 x 14 mm	25

NITOVACIE MATICE, 20 KS

ALU

20x



Č.p.	špecifikácia	
23950	M3 x 9 mm	20
23951	M4 x 11 mm	20
23952	M5 x 12 mm	50
23953	M6 x 14 mm	50
23954	M8 x 16,5 mm	25
23955	M10 x 18 mm	20





FESTA

KLIESTE SPOJOVACIE NA PROFILY PERFORAČNÉ

Č.p.	špecifikácia	
17187	350 mm	6



FESTA

KLIESTE SPOJOVACIE NA PROFILY PERFORAČNÉ

Č.p.	špecifikácia	
17188	250 mm	12



KLIESTE NA HMOŽDINKY

Č.p.	špecifikácia	
17189	255 mm	12



SŤAHOVÁK NA LOŽISKÁ - DVOJRAMENNÝ

Č.p.	max. priemer	hlbka	
23734	Ø 100 mm	50-95 mm	1
23735	Ø 150 mm	100-150 mm	1
23736	Ø 200 mm	110-190 mm	1



SŤAHOVÁK NA LOŽISKÁ - TROJRAMENNÝ

Č.p.	max. priemer	hlbka	
23730	Ø 100 mm	50-95 mm	2
23731	Ø 150 mm	100-150 mm	2
23732	Ø 200 mm	110-190 mm	2

**FESTA****ZVÁRACÍ INVERTOR TIG / MMA 160 A**

Napätie / frekvencia:	230 V / 50 Hz
Napätie naprázdno:	55 V
Regulačný rozsah zváracích prúdov	10 - 160 A
Priemer elektródy:	1,5 - 4,0 mm
Pracovný cyklus:	TIG- 160 A / 60%, MMA - 140 A / 60%
Trieda ochrany:	IP 21
Druh zvárania:	TIG / MMA
Rozmery:	405 x 165 x 270 mm
Technológia:	Anti-stick, Arc-force, Hot start, Lift TIG
Hmotnosť:	6 kg



Č.p.	špecifikácia	
70040	Zvárací invertor TIG / MMA 160A	1
70045	Zváracie káble náhradné	1
70046	Horák TIG náhradný	1

**ELEKTRÓDA RUTILOVÁ ER 117**

certifikované

Č.p.	špecifikácia	množství	
70021	Ø 2,0 x 300 mm	10 ks	1
70020	Ø 2,0 x 300 mm	2,5 kg	8
70026	Ø 2,5 x 300 mm	10 ks	1
70025	Ø 2,5 x 300 mm	2,5 kg	8
70033	Ø 3,2 x 350 mm	10 ks	1
70032	Ø 3,2 x 350 mm	5 kg	4

ELEKTRÓDA BÁZICKÁ

certifikované

Č.p.	špecifikácia	množství	
70030	Ø 2,0 x 300 mm	2,5 kg	1
70031	Ø 2,0 x 300 mm	5 kg	1
70035	Ø 2,5 x 300 mm	2,5 kg	8
70036	Ø 2,5 x 300 mm	10 ks	1
70037	Ø 3,2 x 350 mm	5 kg	5
70038	Ø 3,2 x 350 mm	10 ks	1



FESTA

KUKLA SAMOSTMIEVACIA ZVÁRAČSKÁ

Veľkosť zorného poľa:	98 x 80 mm
Rýchlosť zatmavenia filtra:	1/25 000 s
Zatmavenia filtra:	DIN 5-8 / 9-13
UV / IR ochrana:	DIN 16
Optická trieda:	1 1 1 2
Počet senzorov:	4
Napájanie:	Solárny článok + vymeniteľná batéria CR2450
Pracovný režim:	Zváranie, brúsenie

LCD display



CE EN
379

Č.p.	špecifikácia	
70064	aktívna	1
70066	náhradné krycie plexisklo	1

FESTA

KUKLA SAMOSTMIEVACIA ZVÁRAČSKÁ - CARBON



Č.p.	špecifikácia	
70063	aktívna	4

KUKLA SAMOSTMIEVACIA ZVÁRAČSKÁ

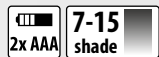

Č.p.	špecifikácia	
70060	aktívna	4

KUKLA ZVÁRAČSKÁ



Č.p.	špecifikácia	
70061		4

OKULIARE ZVÁRAČSKÉ



Č.p.	špecifikácia	
70062		1



SKLÍČKO NÁHRADNÉ KRYCIE DO ZVÁRAČSKEJ KUKLY

2x

Č.p.	špecifikácia	
70065	113 x 80 mm	20



KLADIVO ZVÁRAČSKÉ



Č.p.	špecifikácia	
19115	300 g	1



DRŽIAK ELEKTRODY



Č.p.	špecifikácia	
70070	300 A	1



KLIESTE ZEMNIACE



Č.p.	špecifikácia	
70075	300 A	1



FESTA

MAGNET UHLOVÝ



Č.p.	špecifikácia	nosnosť	
70096	150 x 130 x 30 mm · 45°, 90°, 135°	25 kg	10



MAGNET UHLOVÝ



Č.p.	špecifikácia	nosnosť	
70090	85 x 85 mm · 45°, 90°	9 kg	10



MAGNET UHLOVÝ



Č.p.	špecifikácia	nosnosť	
70093	95 x 64 mm · 30°, 45°, 60°, 75°, 90°	9 kg	10
70094	120 x 90 mm · 30°, 45°, 60°, 75°, 90°	18 kg	10
70095	137 x 110 mm · 30°, 45°, 60°, 75°, 90°	27 kg	10



MAGNET UHLOVÝ



Č.p.	špecifikácia	nosnosť	
70091	95 x 109 x 25 mm · 45°, 90°, 135°	13 kg	10
70092	130 x 150 x 32 mm · 45°, 90°, 135°	22 kg	5



TYČ ZÁVITOVÁ NEREZOVÁ

DIN 976 **INOX**

4.8 · trieda pevnosti

Č.p.	špecifikácia	
55311	M 5 1 m	150
55313	M 8 1 m	50
55314	M 10 1 m	25
55315	M 12 1 m	20
55316	M 14 1 m	15
55317	M 16 1 m	15
55318	M 18 1 m	10
55319	M 20 1 m	10

TYČ ZÁVITOVÁ

DIN 975 **Zn**

4.8 · trieda pevnosti

Č.p.	špecifikácia	
55040	M 4 1 m	200
55050	M 5 1 m	150
55060	M 6 1 m	100
55080	M 8 1 m	50
55100	M 10 1 m	20
55120	M 12 1 m	20
55140	M 14 1 m	15
55160	M 16 1 m	15
55180	M 18 1 m	10
55200	M 20 1 m	10
55220	M 22 1 m	5
55240	M 24 1 m	5
55300	M 30 1 m	5

TYČ ZÁVITOVÁ

DIN 975

4.8 · trieda pevnosti

Č.p.	špecifikácia	
55041	M 4 1 m	200
55051	M 5 1 m	150
55181	M 18 1 m	10
55201	M 20 1 m	10
55221	M 22 1 m	5
55301	M 30 1 m	5

NEW



predtým po



FESTA

ODJEHLOVAČ

1/4"

Č.p. špecifikácia

16321



5



MATICE

DIN 934 **Zn**

4.8 · trieda pevnosti

Č.p.	špecifikácia	
55350	M 4 100 ks	1
55351	M 5 100 ks	1
55352	M 6 100 ks	1
55353	M 8 100 ks	1
55354	M 10 100 ks	1
55355	M 12 100 ks	1
55356	M 14 100 ks	1
55357	M 16 100 ks	1
55358	M 18 100 ks	1
55359	M 20 10 ks	1
55360	M 22 10 ks	1
55361	M 24 10 ks	1
55362	M 30 10 ks	1



PODLOŽKA

DIN 440R **Zn**



Č.p.	špecifikácia	
55331	M 5 100 ks	1
55332	M 6 100 ks	1
55333	M 8 100 ks	1
55334	M 10 100 ks	1
55335	M 12 100 ks	1
55336	M 14 100 ks	1
55337	M 16 100 ks	1
55339	M 20 10 ks	1
55340	M 22 10 ks	1
55341	M 24 10 ks	1
55342	M 30 10 ks	1



**FESTA****KOMPRESOR 6 L - BEZOLEJOVÝ**

Napätie / frekvencia:	230 V / 50Hz
Príkion:	1,2 kW (1,5HP)
Objem nádrže:	6 l
Max. tlak:	8 Bar
Otáčky:	3900 min.
Sací výkon:	180 l/min.
Plniaci výkon:	116 l/min.
Hmotnosť:	10 kg



Č.p.

35360



1

**KOMPRESOR 24 L - BEZOLEJOVÝ**

Výkon:	1100 W
Napájanie:	230 V / 50Hz
Beh bez záťaže:	2850 min-1
Pracovný tlak:	8 bar
Voľný prívod vzduchu:	160 l / min
Typ:	bezolejový
Kapacita zásobníka:	24 L
Hmotnosť:	23 kg



Č.p.

35361 1,1 kW, 24 l



1

**KOMPRESOR 24 L**

Výkon:	1500 W
Napájanie:	230 V / 50Hz
Beh bez záťaže:	2850 min-1
Pracovný tlak:	8 bar
Voľný prívod vzduchu:	200 l / min
Typ:	olejový
Kapacita zásobníka:	24 L
Hmotnosť:	24 kg



Č.p.

35362 1,5 kW, 24 l



1



FESTA

KOMPRESOROVÁ SADA

5x

- Postrekovacia pištoľ so spodnou nádržkou
- Fúkacia pištoľ s manometrom
- Postrekovacia pištoľ s hornou nádržkou
- Ofukovacia pištoľ
- Hadica s rýchlospojками



Č.p. špecifikácia
48001

1

FESTA

KOMPRESOROVÁ SADA

3x

- Fúkacia pištoľ s manometrom
- Ofukovacia pištoľ
- Hadica s rýchlospojками



Č.p. špecifikácia
48002

1



800 ml

FESTA

STRIEKACIA PIŠTOĽ



Č.p. špecifikácia
48015 spodná

1



FESTA

PIŠTOĽ NA SPODKY A DUTINY



Ø 1,4 mm



Č.p. špecifikácia
48036 spodná

1



FESTA

STRIEKACIA PIŠTOĽ



Č.p.	špecifikácia	
48020	horná	1



FESTA

STRIEKACIA PIŠTOĽ



Č.p.	špecifikácia	
48021	horná	1
48047	náhradná tryska Ø 1,7 mm	1



FESTA

STRIEKACIA PIŠTOĽ



Č.p.	špecifikácia	
48022	horná	1
48046	náhradná tryska Ø 1,5 mm	1



FESTA

STRIEKACIA PIŠTOĽ

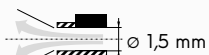

Č.p.	špecifikácia	
48030	dolná	1



STRIEKACIA PIŠTOĽ
NA FARBY A OMIETKY

- 4 - 6 Bar
- 5 l
- tryska Ø 4; 6; 8 mm



Č.p.	špecifikácia	
48037		1



FESTA

PIŠTOĽ OFUKOVACIA



Č.p.	špecifikácia	
48005	krátká	25



FESTA

PIŠTOĽ OFUKOVACIA



Č.p.	špecifikácia	
48006	stredná	25



FESTA

PIŠTOĽ OFUKOVACIA



Č.p.	špecifikácia	
48007	dĺhá	25



FESTA

PIŠTOĽ FÚKACIA S
MANOMETROM

Č.p.	špecifikácia	
48010		1



FESTA

HADICA S RÝCHLOSPOJKAMI

· max. 20 Bar

Č.p.	špecifikácia	
48031	5 m	1
48032	10 m	1
48033	15 m	1
48034	20 m	1



FESTA

HADICA S RÝCHLOSPOJKAMI

Č.p.	špecifikácia	světlost	
48043	5 m	8 atm	1

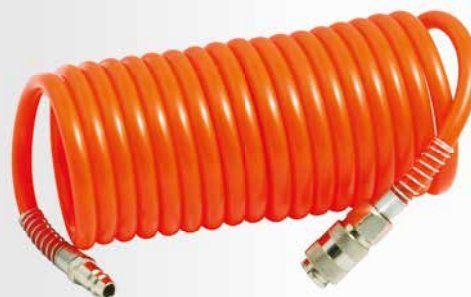

FESTA

HADICA S RÝCHLOSPOJKAMI

Č.p.	špecifikácia	světlost	
48040	5 m	8 atm	1
48041	10 m	8 atm	1
48042	15 m	8 atm	1



FESTA

FILTER

· maximálny tlak 10 bar

Č.p.	špecifikácia	
48008	G 1/4"	1



FESTA

REGULÁTOR TLAKU S
MANOMETROM

· pracovný tlak 0 - 10 bar

Č.p.	špecifikácia	
48009	G 1/4"	1



FESTA

TRYSKY NÁHRADNÉ

· vhodné pre 48021

Č.p.	špecifikácia	
48047	tryska Ø 1,7 mm	1



FESTA

TRYSKY NÁHRADNÉ

· vhodné pre 48022

Č.p.	špecifikácia	
48046	tryska Ø 1,5 mm	1

TABUĽKA ROZMEROV RÚRKOVÝCH ZÁVITOV WHITWORTH

VEĽKOSŤ ZÁVITU G V PALCOCH	MAXIMÁLNY VONKAJŠÍ Ø ZÁVITU V MM
1/8	9,728
1/4	13,157
3/8	16,662
1/2	20,955
3/4	26,441
1	33,249



RÝCHLOSPOJKA

Č.p.	špecifikácia	
48075	1/4' vonkajší	10
48076	3/8' vonkajší	10
48077	1/2' vonkajší	10
48095	1/4' vnútorný	10
48096	3/8' vnútorný	10
48097	1/2' vnútorný	10

REDUKCIA

Č.p.	špecifikácia	
48054	3/8' vonkajší x 1/4' vnútorný	10
48055	1/2' vonkajší x 3/8' vnútorný	10
48056	redukcia 3/8' vonkajší x 1/2' vnútorný	10
48057	redukcia 1/4' vonkajší x 3/8' vnútorný	10

ŠRÚBENIE S VONKAJŠÍMI ZÁVITMI

Č.p.	špecifikácia	
48050	spojka 1/4' vonkajší x 1/4' vonkajší	10
48051	redukcia 1/4' vonkajší x 3/8' vonkajší	10



RÝCHLOSPOJKA | HADICOVÁ VSUVKA

Č.p.	špecifikácia	
48070	1/4' - 6 mm	10
48071	3/8' - 9 mm	10
48072	1/2' - 13 mm	10

ADAPTÉR RÝCHLOSPOJKY | HADICOVÁ VSUVKA

Č.p.	špecifikácia	
48085	1/4' - 6 mm	10
48086	3/8' - 9 mm	10
48087	1/2' - 13 mm	10



ADAPTÉR RÝCHLOSPOJKY

Č.p.	špecifikácia	
48080	1/4' vonkajší	10
48081	3/8' vonkajší	10
48090	3/8' vnútorný	10
48091	1/4' vnútorný	10

HADICOVÁ VSUVKA

Č.p.	špecifikácia	
48060	Ø 6 mm - 1/8' vonkajší	10
48061	Ø 6 mm - 1/4' vonkajší	10
48062	Ø 6 mm - 3/8' vonkajší	10
48063	Ø 9 mm - 1/4' vonkajší	10
48064	Ø 9 mm - 3/8' vonkajší	10
48065	Ø 13 mm - 1/4' vonkajší	10
48066	Ø 13 mm - 3/8' vonkajší	10
48067	Ø 6 mm - 3/8' vnútorný	10
48068	Ø 9 mm - 3/8' vnútorný	10
48093	Ø 6 mm - 1/4' vnútorný	10
48094	Ø 9 mm - 1/4' vnútorný	10



OCHRANNÉ POMÔCKY



OKULIARE OCHRANNÉ

CE EN 166

Č.p. špecifikácia
50510

10



OKULIARE OCHRANNÉ

CE EN 166

Č.p. špecifikácia
50514

10



OKULIARE OCHRANNÉ

nastaviteľná dĺžka straničiek

CE EN 166

Č.p. špecifikácia
50511

12



OKULIARE OCHRANNÉ

CE EN 170

Č.p. špecifikácia
50512 tmavé

12



OKULIARE OCHRANNÉ

CE EN 166

Č.p. špecifikácia
50513

1



SLÚCHADLÁ OCHRANNÉ

CE EN 352 27 dB



Č.p.	špecifikácia	
50563		1



SLÚCHADLÁ OCHRANNÉ

CE EN 352 27 dB



Č.p.	špecifikácia	
50564		1



ŠTÍT OCHRANNÝ PE

CE EN 166

Č.p.	špecifikácia	
50556		10



PRILBA OCHRANNÁ CLIMAX

CE EN 397

MADE IN EU

Č.p.	špecifikácia	
50550	modrá	30
50551	červená	30
50553	biela	30
50554	žltá	30



ŠTÍT OCHRANNÝ S MRIEŽKOU

CE EN 1731

Č.p.	
50562	10



VESTA REFLEXNÁ

CE EN 20471

Č.p.	špecifikácia	
50570	oranžová	100
50571	žltá	100



ZÁTKY DO UŠÍ

Č.p.	špecifikácia	
50560		100



ZÁTKY DO UŠÍ NA ŠNÚRKE

Č.p.	špecifikácia	
50559		100



RESPIRÁTOR

CE EN
149

Č.p.	špecifikácia	
50500	FFP2 bez ventilu	30
50501	FFP1 bez ventilu	30



RESPIRÁTOR

CE EN
149

Č.p.	špecifikácia	
50502	FFP1 s ventilom	20
50503	FFP2 s ventilom	20



RÚŠKA - ÚSTENKA

50x

Č.p.	špecifikácia	
50505		40

MOQ
40



RUKAVICE KOŽENÉ, ZOSILNENÉ

S podšívkou v dlani

CE EN
166

Č.p.	špecifikácia	
50518	velikost 11"	12



RUKAVICE KOŽENÉ, ZOSILNENÉ

S podšívkou v dlani

CE EN
388

Č.p.	špecifikácia	
50519	velikost 10,5"	12



RUKAVICE KOŽENÉ

CE EN
388

Č.p.	špecifikácia	
50520	velikost 10,5"	12



RUKAVICE KOŽENÉ

CE EN
388

Č.p.	špecifikácia	
50521	velikost 10,5"	12



RUKAVICE KOŽENÉ, S TEPLOU PODŠÍVKOU

CE EN
388

Č.p.	špecifikácia	
50523	velikost 11"	12



BAVLNENÉ RUKAVICE S PVC TERČÍKMI

Č.p.	špecifikácia	
50524	velikost 10"	12



RUKAVICE BAVLLENÉ MÁČANÉ V PVC

CE EN
388

Č.p.	špecifikácia	
50525	velikost 10" - 35 cm	12



RUKAVICE POLYESTER S PVC TERČÍKMI

· S PVC terčímkami

Č.p.	špecifikácia	
50526	velikost 10"	12



RUKAVICE BAVLLENÉ MÁČANÉ V LATEXE

CE EN
388

Č.p.	špecifikácia	
50522	velikost 10"	12



RUKAVICE NYLONOVÉ MÁČANÉ V NITRILE

CE EN
388

Č.p.	špecifikácia	
50533	velikost 10"	12



RUKAVICE NYLON MÁČANÉ V LATEXOVEJ PENE

CE EN
388

Č.p.	špecifikácia	
50537	velikost 10"	12



RUKAVICE NYLON MÁČANÉ V NITRILovej PENE

· S PVC terčímkami

CE EN
388

Č.p.	špecifikácia	
50539	velikost 10"	12



RUKAVICE ZIMNÉ AKRYLOVÉ, MÁČANÉ V LATEXE

CE EN
388

Č.p.	špecifikácia	
50529	velikost 10"	12



RUKAVICE ZÁHRADNÉ

Č.p.	špecifikácia	
50557	velikost 7"	12
50558	velikost 8"	12
50549	velikost 9"	12



RUKAVICE BAVLLENÉ

· S PVC terčímkami

Č.p.	špecifikácia	
50531	velikost 9"	12



RUKAVICE MECHANIK – KOZIA KOŽA



Č.p.	špecifikácia	
50541	velikost 9"	12
50542	velikost 10"	12



RUKAVICE MECHANIK, NYLON – BRAVČOVINA



Č.p.	špecifikácia	
50544	velikost 10"	12



RUKAVICE – NYLON, MÁČANÉ V POLYURETÁNE



Č.p.	špecifikácia	
50527	velikost 10"	12



RUKAVICE ZVÁRAČSKÉ, KOŽENÉ



Č.p.	špecifikácia	
50540	velikost 11"	12



RUKAVICE VINYLOVÉ JED-NORAZOVÉ

čire, nepudrované



Č.p.	špecifikácia	
50532	velikost 9"	100



OCHRANŇÁ KOMBINÉZA S KAPUCŇOU

Č.p.	špecifikácia	
50585	velikost M	1
50586	velikost L	1
50587	velikost XL	1
50588	velikost XXL	1



ZÁSTERA NA ZVÁRANIE



Č.p.	špecifikácia	
50555	koža	1



FESTA

OCHRANA KOLIEN



KĽAKADLO POJAZDNÉ

Č.p.	špecifikácia	
37135		1

Č.p.	špecifikácia	
37145	gel	8



FESTA

OCHRANA KOLIEN



Č.p.	špecifikácia	
37140	gel	12

FESTA

OCHRANA KOLIEN



Č.p.	špecifikácia	
37144	gel	12

FESTA

OCHRANA KOLIEN



Č.p.	špecifikácia	
37143		12



FESTA

OCHRANA KOLIEN

Č.p.	špecifikácia	
37142	komfort	20

OCHRANA KOLIEN



Č.p.	špecifikácia	
37139	neopren	10

OCHRANA KOLIEN

Č.p.	špecifikácia	
37141		6

· kvalitná kovová rukoväť, polstrovaná

· popruhy so suchým zipsom pre upevnenie dlhého náradia

· pohodlný ramenný, odnímateľný popruh

· vystužená vnútorná konštrukcia

· 18 vreciek



FESTO

TAŠKA NA NÁRADIE S KOVOVOU RUKOVÄŤOU

č.p.	výška	dĺžka	hlbka
37331	280 mm	490 mm	230 mm



2



FESTO

TAŠKA

č.p.	šírka	výška	hlbka
37332	480 mm	290 mm	250 mm



1



FESTO

TAŠKA

č.p.	šírka	výška	hlbka
37330	610 mm	400 mm	270 mm



5

**FESTA**

PUZDRO NÁRAĎOVÉ

· vystužené vrecká

Č.p.	špecifikácia
37325	



10

**FESTA**

PUZDRO NÁRAĎOVÉ

· vystužené vrecká

Č.p.	špecifikácia
37326	



12

**FESTA**

OPASOK SO SPONOU

Č.p.	špecifikácia
37328	145 cm



20





FESTO

OPASOK MONTÁŽNY - SADA

· 14 vreciek + oko

Č.p.	dĺžka	šírka	
37311	120 cm	6 cm	 1



FESTO

PUZDRO NÁRAĐOVÉ

· 8 vreciek

Č.p.	šírka	výška	
37320	300 mm	250 mm	 1



FESTO

PUZDRO NÁRAĐOVÉ

· 4 vrecká

Č.p.	šírka	výška	
37321	350 mm	300 mm	 1



FESTO

OPASOK NYLONOVÝ

Č.p.	dĺžka	šírka	
37310	120 cm	6 cm	 1



FESTO

VESTA PRACOVNÁ

Č.p.	špecifikácia	
37350		 20



FESTA

PÁS NÁRAĎOVÝ KOŽENÝ



Č.p.	špecifikácia	
37302	6 vreciek	50
37303	11 vreciek	25



PÁS NÁRAĎOVÝ KOŽENÝ



Č.p.	špecifikácia	
37300	6 vreciek	50
37301	11 vreciek	25



BRAŠNA KOŽENÁ PROFESIONÁLNA



Č.p.	výška	dĺžka	hĺbka	
37342	270 mm	430 mm	180 mm	1



BRAŠNA PRE ELEKTRIKÁRA KOŽENÁ



Č.p.	výška	dĺžka	hĺbka	
37341	260 mm	430 mm	200 mm	1



BRAŠNA KOŽENÁ S VYSTUŽENÝM DNOM



Č.p.	výška	dĺžka	hĺbka	
37340	240 mm	430 mm	150 mm	1



BRAŠNA REMESELNÍČKA S POPRUHOM

Č.p.	výška	dĺžka	hĺbka	
37344	250 mm	300 mm	130 mm	1



BRAŠNA S VYSTUŽENÝM DNOM

Č.p.	výška	dĺžka	hĺbka	
37343	240 mm	430 mm	150 mm	1



BRAŠNA PRE ELEKTRIKÁRA

Č.p.	výška	dĺžka	hĺbka	
37345	270 mm	430 mm	180 mm	1



SPONA - KOŽA "O"



Č.p.	špecifikácia	
37308		20



SPONA - KOŽA "U"



Č.p.	špecifikácia	
37309		20

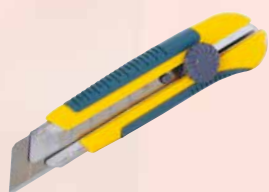

162

ODLAMOVACIE NOŽE KDS



164

ODLAMOVACIE NOŽE
FESTA

170

ŠKRABKY



171

NÁHRADNÉ ČEPEĽE

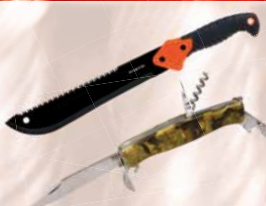

173

NOŽE A MAČETY



178

ZVÁRAČKY, REZAČE,
KLIESTE NA PVC RÚRKY

181

REZAČKY NA POLYSTYRÉN



184

VRTÁKY DO KOVU

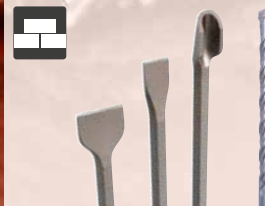

194

VYKRUŽOVÁKY, SEKÁČE,
PRIEBOJNÍKY

198

DIAMANTOVÉ KORUNKY



204

VRTÁKY DO DREVA,
VYKRUŽOVACIE PÍLY, FRÉZY

208

SKĽUČOVADLA

VRTÁKY, REZNÉ
A BRÚSNE NÁSTROJE

160 - 241



210

ROTAČNÉ BRÚSNE KEFY

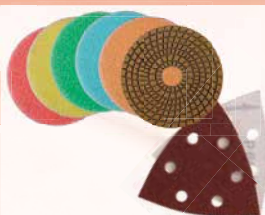

214

BRÚSNE KOTÚČE A PAPIERE



219

RAŠPLE NA SADROKARTÓN



220

PILNÍKY A RAŠPLE



222

PÍLOVÉ KOTÚČE, PLÁTKY



225

PÍLOVÉ PLÁTKY



228

PÍLY NA DREVO, KOV A INÉ



234

DIAMANTOVÉ KOTÚČE



238

REZNÉ A BRÚSNE KOTÚČE

KDS®

Nože japonskej firmy KDS

- Vynikajúca ergonómia rúkaväti
- Vysoký výkon a životnosť britov
- Najlepšie použité materiály britov
- Nízky rezný odpor umožňujúci ľahký rez

KDS® NÓŽ ODLAMOVCÍ



Č.p.	špecifikácia		
16002	LC405	18 mm zelený	25
16011	LB10	náhradné čepele	10



KDS® NÓŽ ODLAMOVCÍ



Č.p.	špecifikácia		
16003	G11	18 mm + 2 čepele	10
16012	GB10	náhradné čepele	10



KDS® NÓŽ ODLAMOVCÍ



Č.p.	špecifikácia		
16019	LI9	18 mm + 2 čepele	10
16011	LB10	náhradné čepele	10
16012	GB10	náhradné čepele	10





KDS®
NÓŽ ODLAMOVCÍ



Č.p.	špecifikácia	
16004	H11 25 mm	10
16013	HB10 náhradné čepele	10



KDS®
NÓŽ ODLAMOVCÍ



Č.p.	špecifikácia	
16005	S14 9 mm + 2 čepele	10
16010	SB10 náhradné čepele	10



KDS®
SKALPEL



Č.p.	špecifikácia	
16006	D12 + 16 čepeľí	10



KDS®
ČEPEĽE NÁHRADNÉ KDS



Č.p.	špecifikácia	
16010	SB10 9 0,38 mm 13 segmentov	20
16011	LB10 18 0,5 mm 15 segmentov	20
16012	GB10 18 0,6 mm 15 segmentov	20
16013	HB10 25 0,7 mm 7 segmentov	10



KDS®
ČEPEĽE NÁHRADNÉ KDS

- Špeciálna zliatina
- Dvojaké brúsenie
- Zvýšená životnosť
- Nízky rezný odpor
- Umožňujúce ľahké rezanie

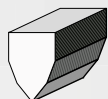

Č.p.	špecifikácia	
16016	LB10B 18 0,5 mm 8 segmentov	20
16017	HB10B 25 0,7 mm 7 segmentov	10



· ilustračné foto

KDS®
STOJAN NA ODLAMOVCIE NOŽE

- osadenie stojanu 16998 : 16001 · 5 ks
- 16003 · 5 ks
- 16004 · 3 ks
- 16005 · 3 ks
- 16006 · 2 ks
- 16008 · 3 ks
- 16010 · 4 ks
- 16012 · 4 ks
- 16013 · 1 ks
- 16016 · 4 ks
- 16018 · 4 ks
- 16019 · 4 ks
- 16020 · 4 ks

Č.p.	špecifikácia	
16999	stojan	1
16998	osadený stojan	1

FESTO
FESTO
NŮŽ ODLAMOVCÍ S KERAMICKOU ČEPELÍ

- 3x ostrejšie než čepeľ oceľová
- 10x dlhšia životnosť
- Žiaruvzdorná, nevodivá, nemagnetická



Č.p.	špecifikácia	
16131	18 mm	10
16066	náhradné čepeľe 18 mm, 5 ks	10

FESTO
NŮŽ ODLAMOVCÍ



Č.p.	špecifikácia	
16110	L11 18 mm + 1 čepeľ	12

FESTO
NŮŽ ODLAMOVCÍ

Č.p.	špecifikácia	
16100	L12 18 mm + 1 čepeľ	12

FESTO
NŮŽ ODLAMOVCÍ

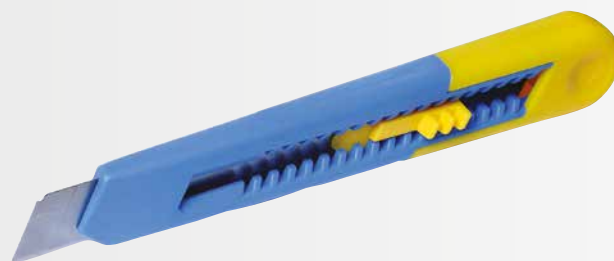
Č.p.	špecifikácia	
16105	L17 18 mm + 1 čepeľ	12

FESTO
NŮŽ ODLAMOVCÍ

Č.p.	špecifikácia	
16125	L4 9 mm	24
16120	L8 18 mm	24

FESTO
NŮŽ ODLAMOVCÍ

Č.p.	špecifikácia	
16115	L10 9 mm	24

FESTO
NŮŽ ODLAMOVCÍ

Č.p.	špecifikácia	
16150	18 mm	24
16151	18 mm bez loga FESTO	20



FESTA

NÓŽ ODLAMOVCÍ

ALU



Č.p. 16136
špecifikácia 18 mm

1



FESTA

NÓŽ ODLAMOVCÍ

ALU



Č.p. 16137
špecifikácia 25 mm

12



FESTA

NÓŽ ODLAMOVCÍ

• Protišmykové pogumovanie

+4 ALU



Č.p. 16090
špecifikácia 18 mm

12



FESTA

NÓŽ ODLAMOVCÍ

• Protišmykové pogumovanie

+4 ALU



Č.p. 16091
špecifikácia 25 mm

6



FESTA

NÓŽ ODLAMOVCÍ

• Protišmykové pogumovanie

ALU



Č.p. 16145
špecifikácia L25 18 mm

12



FESTA

NÓŽ ODLAMOVCÍ

• Protišmykové pogumovanie

ALU



Č.p. 16144
špecifikácia L24 18 mm

12



NÓŽ ODLAMOVCÍ

ALU



Č.p. 16143
špecifikácia 18 mm

12



NÓŽ ODLAMOVCÍ

ALU



Č.p. 16142
špecifikácia 18 mm

12



NÓŽ ODLAMOVCÍ

ALU



Č.p.	špecifikácia
16025	18 mm

12



FESTA

NÓŽ ODLAMOVCÍ

ALU



Č.p.	špecifikácia
16029	18 mm

25



FESTA

NÓŽ ODLAMOVCÍ

- Protišmykové pogumovanie



Č.p.	špecifikácia
16146	18 mm

12



FESTA

NÓŽ ODLAMOVCÍ

- Protišmykové pogumovanie



Č.p.	špecifikácia
16147	25 mm

12



FESTA

NÓŽ ODLAMOVCÍ

- Protišmykové pogumovanie



Č.p.	špecifikácia
16130	L18 18 mm + 5 čepeľek

12



FESTA

NÓŽ ODLAMOVCÍ

- Protišmykové pogumovanie



Č.p.	špecifikácia
16135	L20 25 mm + 5 čepeľek

6



FESTA

NÓŽ ODLAMOVCÍ

- Protišmykové pogumovanie



Č.p.	špecifikácia
16140	L22 18 mm

12



FESTA

NÓŽ ODLAMOVCÍ

- Protišmykové pogumovanie

ALU



Č.p.	špecifikácia
16034	25 mm

12



FESTA

NÓŽ ODLAMOVCÍ

INOX



Č.p.	špecifikácia
16085	9 mm

24



FESTA

NÓŽ ODLAMOVCÍ

INOX



Č.p.	špecifikácia
16086	18 mm

24



NÓŽ BEZPEČNOSTNÝ

· samozatahováacia čepeľ

Č.p.	špecifikácia
16057	135 mm

12



16074

FESTA

NÓŽ BEZPEČNOSTNÝ

ALU

INOX



Č.p.	špecifikácia
16058	
16074	náhradné čepeľe 10 ks

6

1



FESTA

NÓŽ TURBO

+5

ALU



Č.p.	špecifikácia
16037	+ 5 čepeľek

6



FESTA

NÓŽ ZATVÁRACÍ

+5

ALU



Č.p.	špecifikácia
16023	+ 5 čepeľek
16071	náhradné čepeľe 10 ks

12

10



FESTA

NÓŽ ZATVÁRACÍ, SADA ČEPELÍ

ALU

Č.p.	špecifikácia
16095	25 čepeľek

1

**FESTA****NÔŽ S ARETÁCIOU**

· Protišmykové pogumovanie



Č.p.	špecifikácia
16035	+ 2 čepeľek

12

**FESTA****NÔŽ S ARETÁCIOU**

Č.p.	špecifikácia
16033	NP 110 + 3 čepeľek

5

**FESTA****NÔŽ S ARETÁCIOU**

Č.p.	špecifikácia
16038	+ 5 čepeľek

12

**NÔŽ S ARETÁCIOU**

Č.p.	špecifikácia
16032	NP 109

48

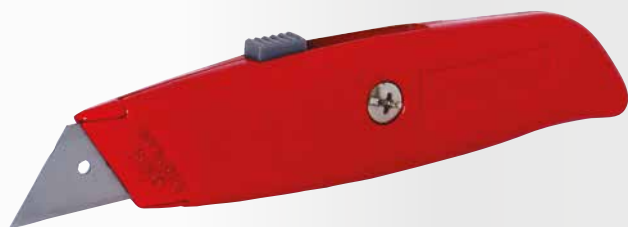
**NÔŽ S ARETÁCIOU**

Č.p.	špecifikácia
16031	NS 107 B

24

**NÔŽ**

Č.p.	špecifikácia
16030	NS 107

24

**NÔŽ NA PODLAHOVINY**

· na koberce a podlahové krytiny

Č.p.	špecifikácia
16036	45 mm

12

**NÔŽ HÁKOVÝ**

· na koberce a podlahové krytiny

Č.p.	špecifikácia
16041	

12



NÔŽ ODLAMOVCÍ

ALU



Č.p.	špecifikácia	
16046	18 mm	12



NÔŽ ODLAMOVCÍ

Č.p.	špecifikácia	
16028	S 201 18 mm	24

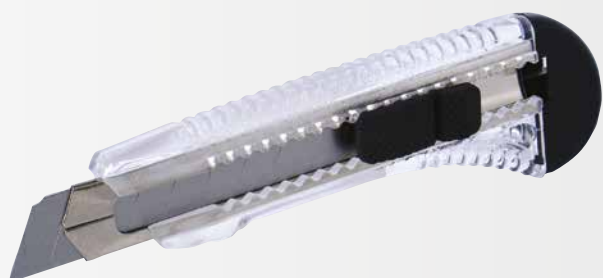

NÔŽ ODLAMOVCÍ

Č.p.	špecifikácia	
16026	P 205 18 mm	30



NÔŽ ODLAMOVCÍ

Č.p.	špecifikácia	
16021	P 201 9 mm	60



NÔŽ ODLAMOVCÍ

HOBBY

Č.p.	špecifikácia	
16024	P 204 18 mm	60



NÔŽ ODLAMOVCÍ

· Protišmykové pogumovanie

Č.p.	špecifikácia	
16141	18 mm	24



MOQ 24



SADA NOŽOV

HOBBY 12x

Č.p.	špecifikácia	
16053	9 mm	12
16055	18 mm	12



SADA NOŽOV

HOBBY 3x

Č.p.	špecifikácia	
16043		24





50 mm

ŠKRABKA

ALU



Č.p.	špecifikácia	
16059	50 mm	10
16082	náhradné čepele	1



100 mm

ŠKRABKA

ALU



· na použitie s 18 mm čepeľami k odlamovacím nožom

Č.p.	špecifikácia	
16054	100 mm	1



38 mm

FESTA

ŠKRABKA POGUMOVANÁ

· Protišmykové pogumovanie



Č.p.	špecifikácia	
16049		12
16069	náhradné čepele	1



100 mm

FESTA

ŠKRABKA



Č.p.	špecifikácia	
16052	48 cm dĺžka	6
16070	čepeľ	25



60 mm

ŠKRABKA



Č.p.	špecifikácia	
16051		24



55 mm

ŠKRABKA



Č.p.	špecifikácia	
16050		24



SADA NA APLIKÁCIU A ODSTRÁNENIE SILIKÓNU

3x



Č.p.	špecifikácia	
16042		12



FESTA

ČEPEL' NÁHRADNÁ

- 7 segmentov
- 3x dlhšia životnosť
- dvojité brúsenie
- nízky rezný odpor

SK2 10x

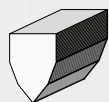

20

Č.p.	špecifikácia
16064	25 0,7 mm



ČEPEL' NÁHRADNÁ

- 7 segmentov

10x

20

Č.p.	špecifikácia
16068	25 0,6 mm



FESTA

ČEPEL' NÁHRADNÁ

- 8 segmentov
- 3x dlhšia životnosť
- dvojité brúsenie
- nízky rezný odpor

SK2 10x

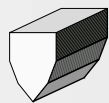

10

Č.p.	špecifikácia
16062	18 0,7 mm



FESTA

ČEPEL' NÁHRADNÁ

- 15 segmentov
- 3x dlhšia životnosť
- dvojité brúsenie
- nízky rezný odpor

SK2 10x

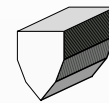

10

Č.p.	špecifikácia
16063	18 0,7 mm



FESTA

ČEPEL' NÁHRADNÁ KERAMICKÁ

- 8 segmentov
- 3x ostrejšia než čepel' oceľová
- 10x dlhšia životnosť
- Žiaruvzdorná, nevodivá, nemagnetická

5x

10

Č.p.	špecifikácia
16066	18 0,6 mm



ČEPEL' NÁHRADNÁ

- 4 segmenty

10x

10

Č.p.	špecifikácia
16067	18 0,5 mm



ČEPEL' NÁHRADNÁ

- 8 segmentov

10x

60

Č.p.	špecifikácia
16065	18 0,5 mm



ČEPEL' NÁHRADNÁ

- 15 segmentov

10x

60

Č.p.	špecifikácia
16081	18 0,5 mm



ČEPEL' NÁHRADNÁ

- 8 segmentov

- dvojité brúsenie

10x



25

Č.p.	špecifikácia
16078	18 0,5 mm



ČEPEL' NÁHRADNÁ

- 8 segmentov

- dvojité brúsenie

10x



Č.p.	špecifikácia
16077	18 0,6 mm



25



ČEPEL' NÁHRADNÁ 30°

· 7 segmentov

10x

Č.p. 16061
špecifikácia 9 | 0,4 mm



60



ČEPEL' NÁHRADNÁ

· 13 segmentov

10x

Č.p. 16060
špecifikácia 9 | 0,45 mm

10



FESTA

ČEPEL' NÁHRADNÁ

· pre 16058

10x

Č.p. 16074
špecifikácia

1



FESTA

ČEPEL' NÁHRADNÁ

10x



Č.p. 16072
špecifikácia R 004



FESTA

ČEPEL' NÁHRADNÁ

10x



Č.p. 16075
špecifikácia R 003

10



ČEPEL' NÁHRADNÁ

10x

Č.p. 16071
špecifikácia R 001

60



ČEPEL' NÁHRADNÁ

10x

Č.p. 16073
špecifikácia R 002

60



ČEPEL' NÁHRADNÁ

5x

Č.p. 16084
špecifikácia 18 mm

50

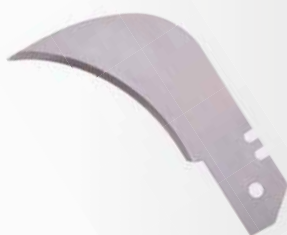

ČEPEL' NÁHRADNÁ

5x

Č.p. 16083
špecifikácia 18 mm

50



ČEPEL' NÁHRADNÁ

· pre 34315

Č.p. 34316
špecifikácia

1



ČEPEL' NÁHRADNÁ NA ŠKRABKU

· pre 16052

Č.p. 16070
špecifikácia 100 mm

25



FESTA

NŮŽ LOVECKÝ

- Nylonová rukoväť
- Čepeľ s teflónovým povrchom
- Puzdro s poistkou a klipom



Č.p.	špecifikácia	
16234	21 10 cm	10



FESTA

NŮŽ LOVECKÝ



Č.p.	špecifikácia	
16229	23 10 cm	12



FESTA

DLÁTO STOLÁRSKE MULTIFUNKČNÉ

- zosilnená čepeľ



Č.p.	špecifikácia	
16231	20 8 cm	12



NŮŽ TECHNICKÝ

- zosilnená čepeľ



Č.p.	špecifikácia	
16230	21 10 cm	12



NŮŽ



Č.p.	špecifikácia	
16022	16 6,5 cm	100



FESTA

NŮŽ ZAHNUTÝ NA PODLAHOVINY

Č.p.	špecifikácia	
16225	20 8,5 cm	12



FESTA

NŮŽ ELEKTRIKÁRSKY

- zosilnená čepeľ



Č.p.	špecifikácia	
16212	15 3,2 cm	12



FESTA

NŮŽ ODIZOLOVACÍ

Č.p.	špecifikácia	
16201	Ø 8 - 27 mm	10

**FESTA**

NÓŽ ELEKTRIKÁRSKY

INOX



Č.p.	špecifikácia
16211	20 8,5 cm

10

**FESTA**

NÓŽ ELEKTRIKÁRSKY

INOX



Č.p.	špecifikácia
16210	20,5 9 cm

10

**FESTA**

NÓŽ OČKOVACÍ

INOX



Č.p.	špecifikácia
16219	19 11 cm

24

**FESTA**

NÓŽ VRÚBĽOVACÍ

INOX



Č.p.	špecifikácia
16218	18,5 10,5 cm

24

**FESTA**

NÓŽ ŠTEPÁRSKY

INOX



Č.p.	špecifikácia
16220	18,5 11 cm

24

**FESTA**

NÓŽ ZATVÁRACÍ

INOX



Č.p.	špecifikácia
16235	17,5 8,5 cm

24

**FESTA**

NÓŽ ZATVÁRACÍ

INOX



Č.p.	špecifikácia
16221	21 12 cm

24

**FESTA**

NÓŽ ZATVÁRACÍ

INOX



Č.p.	špecifikácia
16236	22,5 10 cm

24



FESTA

NŮŽ ZATVÁRACÍ



Č.p.	špecifikácia
16209	14,5 5,5 cm

1



FESTA

NŮŽ ZATVÁRACÍ

INOX



Č.p.	špecifikácia
16222	20 12 cm

24



FESTA

NŮŽ ZATVÁRACÍ

INOX ALU



Č.p.	špecifikácia
16223	18,5 10,5 cm

24



FESTA

NŮŽ ZATVÁRACÍ MULTIFUNKČNÝ

• 10 funkcií

INOX



Č.p.	špecifikácia
16226	17,5 7 cm

24



FESTA

NŮŽ ZATVÁRACÍ MULTIFUNKČNÝ

• 5 funkcií

INOX



Č.p.	špecifikácia
16228	27 10,5 cm

24



NŮŽ ZATVÁRACÍ LOVECKÝ

• 3 funkcie



Č.p.	špecifikácia
16227	20,5 10 cm

24



NŮŽ ZATVÁRACÍ MULTIFUNKČNÝ

• 7 funkcií

INOX



Č.p.	špecifikácia
16224	17,5 7 cm

24

**FESTA****KLIŠTE MULTIFUNKČNÉ**

- 9 funkcií
- púzdro

CrV

Č.p. špecifikácia
16232



12

**FESTA****NÔŽ NA MINERÁLNU VATU**

Č.p. špecifikácia
16198 44,5 | 33 cm

12

**FESTA****NÔŽ NA IZOLÁCIE**

- na minerálnu vatu, polystyrén



Č.p. špecifikácia
16199 48 | 35 cm

10

**FESTA****MAČETA****TEFLON**

Č.p. špecifikácia
45069 440 mm

6

**FESTA****MAČETA****TEFLON**

Č.p. špecifikácia
44950 490 mm

4

**MAČETA NEREZ****INOX**

Č.p. špecifikácia
45083 430 mm
45084 600 mm

12
6

**MAČETA**

- rukoväť vyrobená z jaseňového dreva

Č.p. špecifikácia
45081 510 mm
45082 710 mm

36
36



SADA SKALPELOV

23x



24

Č.p. 16282 špecifikácia



SADA SKALPELOV

13x



10

Č.p. 16281 špecifikácia



BRÚSNY KAMEŇ OVÁLNY

Č.p. 45370 špecifikácia

250 x 33 x 18 mm



20

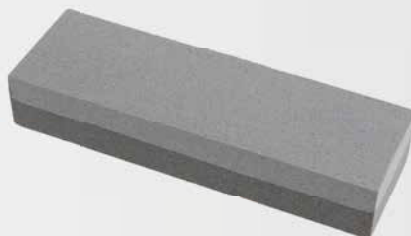

BRÚSNY KAMEŇ

Č.p. 45045 špecifikácia

150 x 50 x 30 mm



1



OSLA NA KOSU

Č.p. 45046 špecifikácia

205 x 15 mm



100



BRÚSKA NA NOŽE A NOŽNICE

Č.p. 16991 špecifikácia

20



20



BRÚSKA NA NOŽE A NOŽNICE

Č.p. 16990 špecifikácia

Ø 50 mm



1



BRÚSKA NA NOŽE A NOŽNICE

Č.p. 45048 špecifikácia

20



20



BRÚSKA NA NOŽE A NOŽNICE 6 V 1

Č.p. 45068 špecifikácia

10



10



WINLAND



WINLAND

**FESTA****POLYFÚZNÁ ZVÁRAČKA PLASTOVÝCH RÚR**

- Napätie / frekvencia 230 V / 50 Hz
- príkon 750 / 1500 W
- teplota 0-300 C°
- nástavce Ø 20,25,32,40,50,63 mm
- váha 1,6 kg



Súčasť balenia: meter, vodováha, skrutkovač, inbus kľúč, nožnice na rúrky, 6x zvrací nástavec, stojan, plechový kufor



Č.p.

17182

**FESTA****HROTOVÁ POLYFÚZNÁ ZVÁRAČKA PLASTOVÝCH RÚR**

- Napätie / frekvencia 230 V / 50 Hz
- príkon 800 / 1000 W
- teplota 0-300 C°
- nástavce Ø 16, 20, 25, 32 mm
- váha 1 kg



súčasť balenia: inbus, 4x zvrací nástavec, stojan, plechový kufor



Č.p.

17183





FESTA®



FESTA®

KLIESTE NA PVC RÚRKY

ID max. 42 mm



Č.p.	špecifikácia	
17027		10
16315	náhradné čepele	1



ČEPEĽ NÁHRADNÁ PRE KLIESTE

· pre kliešte 17027

Č.p.	špecifikácia	
16315		1

NEW



FESTA®

KLIESTE NA PVC RÚRKY

ID max. 32 mm



Č.p.	špecifikácia	
17037		12



KLIESTE NA PVC RÚRKY

ID max. 42 mm



Č.p.	špecifikácia	
17026		6



FESTA®

NOŽNICE NA PVC LIŠTY A RÚRKY

· lišty, rúrky, profily

Ø 17 mm Ø 20 mm Ø 27 mm

5x

Č.p.	špecifikácia	
17050		8



8

**FESTA**

REZAČ TENKOSTENNÝCH TRUBIEK

ID 3-22
mm

Č.p.	špecifikácia	
16301		10
16311	náhradné koliesko	1

**FESTA**

REZAČ TENKOSTENNÝCH TRUBIEK

ID 6-64
mm

Č.p.	špecifikácia	
16304		6
16312	náhradné koliesko	1



REZAČ TENKOSTENNÝCH TRUBIEK

ID 3-32
mm

Č.p.	špecifikácia	
16303		10
16311	náhradné koliesko	1



REZAČ TENKOSTENNÝCH TRUBIEK

ID 3-32
mm

Č.p.	špecifikácia	
16300		10
16310	náhradné koliesko	1

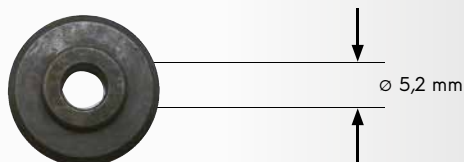
**NEW**

before after

KOLIESKO NÁHRADNÉ
PRE REZAČE PVC TRUBIEK

Č.p.	špecifikácia	
16310	Ø 17,5 mm x 6 m pre 16300	1
16311	Ø 18,0 mm x 4,5 mm pre 16303, 16301	1
16312	Ø 27,5 mm x 6 mm pre 16304	1

ODIHLOVAČ

1/4"



Č.p.	špecifikácia	
16321		1

ODIHLOVAČ NA RÚRKY

ID 6-32
mm

Č.p.	špecifikácia	
16320		1



FRÉZA ODIHLOVACIA, RUČNÉ HSS

1/4" HSS

4x

Č.p.	špecifikácia	
20360		10



ODIHLOVAČ



Č.p.	špecifikácia	
20361		1



FESTA

REZAČKA POLYSTYRÉNU AKUMULÁTOROVÁ

- batérie 36 V, 1,5Ah Li-ion
- výkon 180 W
- teplota max 350 C°
- dĺžka čepele 20 cm



· Vybavenie: 2 ks batérie, nabíjačka, čepeľ, čistiaca mosadzná kefa, inbus

Č.p.	špecifikácia
35323	



FESTA

REZAČKA POLYSTYRÉNU ELEKTRICKÁ

- Napätie / frekvencia 230 V/50 Hz
- príkon 250 W
- teplota 50-600 C°
- dĺžka čepele 25 cm
- dĺžka prívodného kábla 3 m



· Vybavenie: čistiaca mosadzná kefa, inbus, nôž 25 a 30 cm, kufr

Č.p.	špecifikácia	
35326	Elektrická rezačka polystyrénu	1
35328	Náhr. nôž do rezačky polystyrénu 14 cm	1
35329	Náhr. nôž do rezačky polystyrénu 25 cm	1



VODIACA LIŠTA PRE REZAČKU POLYSTYRÉNU

· pre 35323, 35326

Č.p.	špecifikácia	
35327	vodiaca lišta	1
35335	Náhradný nôž - 30 cm	1

FESTA

REZAČKA POLYSTYRÉNU ELEKTRICKÁ



· regulácia teploty

Č.p.	špecifikácia
35325	220 W



NEW



FESTA

REZAČKA POLYSTYRÉNU STRUNOVÁ

- Napätie / frekvencia: 230 V/50 Hz
 - Príkon: 160 W
 - Dĺžka rezu: 137 cm
 - Výška rezu: 30 cm
 - Krytie: IP44
 - Uhol rezu: 0° - 90°
- vybavenie: stojan, nožný spínač, držiak na lešenie, 2x Ni-Cr rezací drôt, čistiaca mosadzná kefa, náradie a spojovací materiál, plastový box s kolieskami



Č.p. Špecifikácia

35348



1

NEW



1,7 m

FESTA

NOŽNÝ SPÍNAČ
PRE REZAČKU POLYSTYRÉNU

pre 35330, 35345, 35348

Č.p. Špecifikácia

35334



1

NEW



FESTA

STOJAN
PRE REZAČKU POLYSTYRÉNU

pre 35330, 35345, 35348

Č.p. Špecifikácia

35336



1

NEW



FESTA

NÁHRADNÁ PRUŽINA
PRE REZAČKU POLYSTYRÉNU

pre 35330, 35345, 35348

Č.p. Špecifikácia

35332



1

NEW



FESTA

DRŽIAK NA LEŠENIE
PRE REZAČKU POLYSTYRÉNU

pre 35330, 35345, 35348

Č.p. Špecifikácia

35333



1

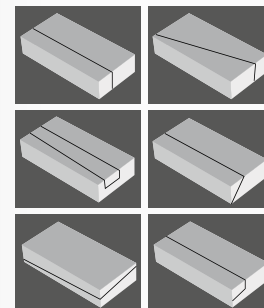
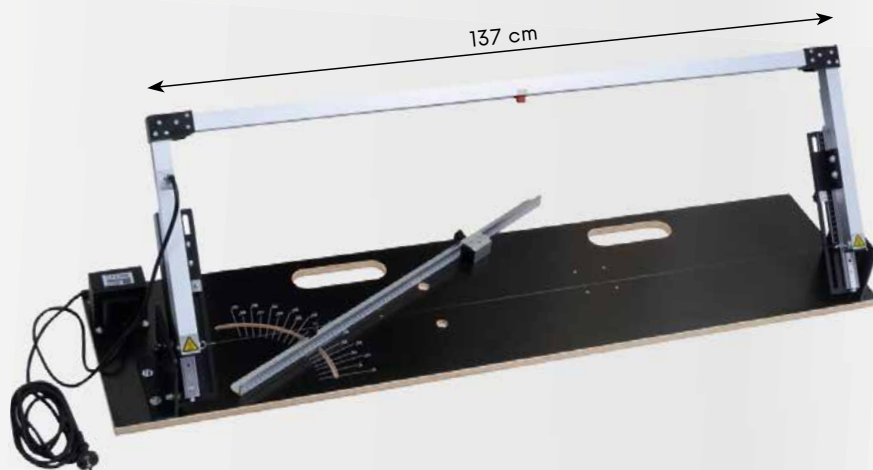

FESTA

REZAČKA POLYSTYRÉNU STRUNOVÁ

- Napätie / frekvencia: 230 V / 50 Hz
- Príkion: 160 W
- Dĺžka rezu: 137 cm
- Výška rezu: 30 cm
- Krytie: IP44
- Uhol rezu: 0° - 90°



• vybavenie: Ni-Cr rezací drôt, čistiaca mosadzná kefa, inbus



Č.p.	špecifikácia	
35345	Rezačka polystyrénu 1500 x 450 mm	1
35346	Náhradná rezná struna Ni-Cr	1
35347	náhradný zdroj	1

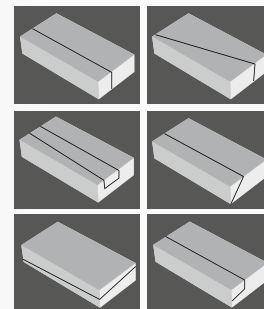
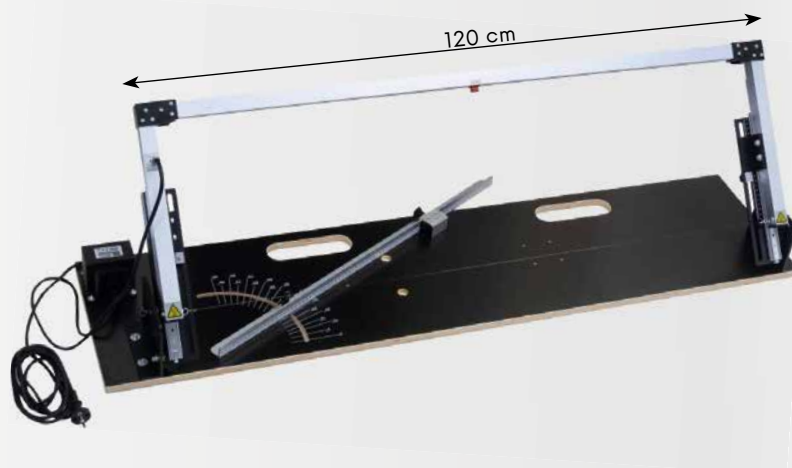

FESTA

REZAČKA POLYSTYRÉNU STRUNOVÁ

- Napätie / frekvencia: 230 V / 50 Hz
- Príkion: 160 W
- Dĺžka rezu: 120 cm
- Výška rezu: 30 cm
- Krytie: IP44
- Uhol rezu: 0° - 90°



• vybavenie: Ni-Cr rezací drôt, čistiaca mosadzná kefa, inbus

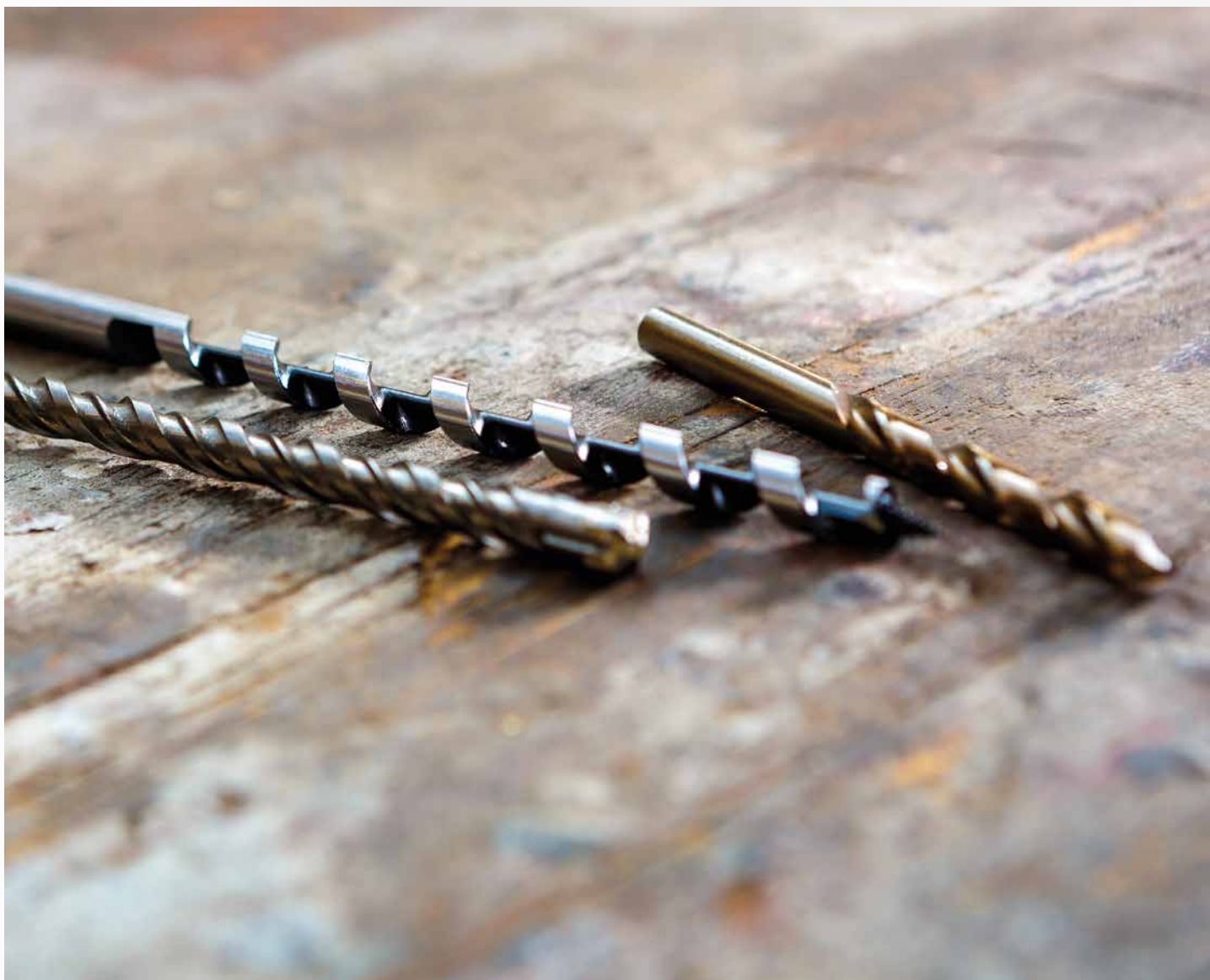

Č.p.	špecifikácia	
35330	Rezačka polystyrénu 1350 x 450 mm	1
35331	Náhradná rezná struna Ni-Cr	1
35347	náhradný zdroj	1

**FESTA****VRTÁK VYBRÚSENÝ DO KOVU HSS-G COBALT 5%**

Co 5%, W 6%	HSS	DIN 338	135°
Mo 5%, Cr 4%, V 4%			

INOX	1400 MPa
------	----------



Č.p.	špecifikácia		Č.p.	špecifikácia		Č.p.	špecifikácia	
22510	Ø 1,00 mm	1	22548	Ø 4,80 mm	1	22590	Ø 9,00 mm	1
22515	Ø 1,50 mm	1	22550	Ø 5,00 mm	1	22595	Ø 9,50 mm	1
22520	Ø 2,00 mm	1	22555	Ø 5,50 mm	1	22600	Ø 10,00 mm	1
22525	Ø 2,50 mm	1	22560	Ø 6,00 mm	1	22602	Ø 10,20 mm	1
22530	Ø 3,00 mm	1	22565	Ø 6,50 mm	1	22605	Ø 10,50 mm	1
22532	Ø 3,20 mm	1	22568	Ø 6,80 mm	1	22610	Ø 11,00 mm	1
22535	Ø 3,50 mm	1	22570	Ø 7,00 mm	1	22615	Ø 11,50 mm	1
22540	Ø 4,00 mm	1	22575	Ø 7,50 mm	1	22620	Ø 12,00 mm	1
22542	Ø 4,20 mm	1	22580	Ø 8,00 mm	1	22625	Ø 12,50 mm	1
22545	Ø 4,50 mm	1	22585	Ø 8,50 mm	1	22630	Ø 13,00 mm	1



FESTA

VRTÁK VYBRÚSENÝ DO KOVU HSS-G W 9 %

W 9%, Mo 3%
Cr 4%, V 1% **HSS** **DIN 338**

INOX **1100 MPa**

MOQ



Č.p.	špecifikácia	
19530	Ø 1,00 mm	10
19532	Ø 1,20 mm	10
19533	Ø 1,30 mm	10
19534	Ø 1,40 mm	10
19535	Ø 1,50 mm	10
19536	Ø 1,60 mm	10
19537	Ø 1,70 mm	10
19538	Ø 1,80 mm	10
19539	Ø 1,90 mm	10
19540	Ø 2,00 mm	10
19541	Ø 2,10 mm	10
19542	Ø 2,20 mm	10
19543	Ø 2,30 mm	10
19544	Ø 2,40 mm	10
19545	Ø 2,50 mm	10
19546	Ø 2,60 mm	10
19547	Ø 2,70 mm	10
19548	Ø 2,80 mm	10
19550	Ø 3,00 mm	10
19552	Ø 3,20 mm	10
19553	Ø 3,30 mm	10
19554	Ø 3,40 mm	10
19555	Ø 3,50 mm	10
19556	Ø 3,60 mm	10

Č.p.	špecifikácia	
19557	Ø 3,70 mm	10
19558	Ø 3,80 mm	10
19559	Ø 3,90 mm	10
19560	Ø 4,00 mm	10
19561	Ø 4,10 mm	10
19562	Ø 4,20 mm	10
19563	Ø 4,30 mm	10
19564	Ø 4,40 mm	10
19565	Ø 4,50 mm	10
19567	Ø 4,70 mm	10
19568	Ø 4,80 mm	10
19569	Ø 4,90 mm	5
19570	Ø 5,00 mm	5
19573	Ø 5,30 mm	5
19574	Ø 5,40 mm	5
19575	Ø 5,50 mm	5
19576	Ø 5,60 mm	5
19577	Ø 5,70 mm	5
19578	Ø 5,80 mm	5
19579	Ø 5,90 mm	5
19580	Ø 6,00 mm	5
19581	Ø 6,10 mm	5
19583	Ø 6,30 mm	5
19584	Ø 6,40 mm	5

Č.p.	špecifikácia	
19585	Ø 6,50 mm	5
19586	Ø 6,60 mm	5
19587	Ø 6,70 mm	5
19588	Ø 6,80 mm	5
19589	Ø 6,90 mm	5
19590	Ø 7,00 mm	5
19591	Ø 7,10 mm	5
19593	Ø 7,30 mm	5
19594	Ø 7,40 mm	5
19595	Ø 7,50 mm	5
19596	Ø 7,60 mm	5
19597	Ø 7,70 mm	5
19598	Ø 7,80 mm	5
19599	Ø 7,90 mm	5
19600	Ø 8,00 mm	5
19601	Ø 8,10 mm	5
19603	Ø 8,30 mm	5
19604	Ø 8,40 mm	5
19605	Ø 8,50 mm	5
19606	Ø 8,60 mm	5
19607	Ø 8,70 mm	5
19608	Ø 8,80 mm	5
19609	Ø 8,90 mm	5
19610	Ø 9,00 mm	5
19611	Ø 9,10 mm	5
19612	Ø 9,20 mm	5
19613	Ø 9,30 mm	5
19614	Ø 9,40 mm	5
19615	Ø 9,50 mm	3
19616	Ø 9,60 mm	3
19617	Ø 9,70 mm	3
19618	Ø 9,80 mm	3
19619	Ø 9,90 mm	3
19620	Ø 10,00 mm	3
19621	Ø 10,10 mm	3
19622	Ø 10,20 mm	3
19623	Ø 10,30 mm	3
19624	Ø 10,40 mm	3
19625	Ø 10,50 mm	3
19626	Ø 10,60 mm	3

Č.p.	špecifikácia	
19627	Ø 10,70 mm	3
19628	Ø 10,80 mm	3
19629	Ø 10,90 mm	3
19630	Ø 11,00 mm	3
19631	Ø 11,10 mm	3
19632	Ø 11,20 mm	3
19633	Ø 11,30 mm	3
19634	Ø 11,40 mm	3
19635	Ø 11,50 mm	3
19636	Ø 11,60 mm	3
19637	Ø 11,70 mm	3
19638	Ø 11,80 mm	3
19639	Ø 11,90 mm	3
19640	Ø 12,00 mm	3
19641	Ø 12,10 mm	3
19642	Ø 12,20 mm	3
19643	Ø 12,30 mm	3
19644	Ø 12,40 mm	3
19645	Ø 12,50 mm	3
19646	Ø 12,60 mm	1
19647	Ø 12,70 mm	1
19648	Ø 12,80 mm	1
19649	Ø 12,90 mm	1
19650	Ø 13,00 mm	1
19651	Ø 13,20 mm R13	1
19652	Ø 13,50 mm R13	1
19653	Ø 14,00 mm R13	1
19654	Ø 14,50 mm R13	1
19655	Ø 15,00 mm R13	1
19656	Ø 15,50 mm R13	1
19657	Ø 16,00 mm R13	1
19658	Ø 16,50 mm R13	1
19659	Ø 17,00 mm R13	1
19660	Ø 17,50 mm R13	1
19661	Ø 18,00 mm R13	1
19662	Ø 18,50 mm R13	1
19663	Ø 19,00 mm R13	1
19664	Ø 19,50 mm R13	1
19665	Ø 20,00 mm R13	1



FESTA

BOX S VYBRÚSENÝMI VRTÁKMI DO KOVU HSS-G W 9 %

W 9%, Mo 3%
Cr 4%, V 1% **HSS** **DIN 338**

INOX **1100 MPa**

Č.p.	špecifikácia	
19669		1
90191	bez vrtákov	1

Č.p.	obsah sady	Č.p.	obsah sady
19530	Ø 1,00 mm 20x	19585	Ø 6,50 mm 15x
19535	Ø 1,50 mm 20x	19590	Ø 7,00 mm 15x
19540	Ø 2,00 mm 20x	19595	Ø 7,50 mm 15x
19545	Ø 2,50 mm 20x	19600	Ø 8,00 mm 15x
19550	Ø 3,00 mm 20x	19605	Ø 8,50 mm 15x
19552	Ø 3,20 mm 20x	19610	Ø 9,00 mm 15x
19555	Ø 3,50 mm 20x	19615	Ø 9,50 mm 15x
19558	Ø 3,80 mm 20x	19620	Ø 10,00 mm 15x
19560	Ø 4,00 mm 30x	19625	Ø 10,50 mm 6x
19562	Ø 4,20 mm 20x	19630	Ø 11,00 mm 6x
19565	Ø 4,50 mm 20x	19635	Ø 11,50 mm 6x
19568	Ø 4,80 mm 20x	19640	Ø 12,00 mm 6x
19570	Ø 5,00 mm 15x	19645	Ø 12,50 mm 6x
19575	Ø 5,50 mm 15x	19650	Ø 13,00 mm 6x
19580	Ø 6,00 mm 30x		

**FESTA****VRTÁK VYBRÚSENÝ DO KOVU**W 4%, Mo 3%
Cr 4%, V 1%**HSS****DIN
338****ALU****900
MPa****MOQ**

Č.p.	špecifikácia	
19670	Ø 0,6 mm	10
19671	Ø 0,8 mm	10
19672	Ø 0,9 mm	10
19673	Ø 1,0 mm	10
19674	Ø 1,1 mm	10
19675	Ø 1,2 mm	10
19676	Ø 1,3 mm	10
19677	Ø 1,4 mm	10
19678	Ø 1,5 mm	10
19679	Ø 1,6 mm	10
19680	Ø 1,7 mm	10
19681	Ø 1,8 mm	10
19682	Ø 1,9 mm	10
19683	Ø 2,0 mm	10
19684	Ø 2,1 mm	10
19685	Ø 2,2 mm	10
19686	Ø 2,3 mm	10
19687	Ø 2,4 mm	10
19688	Ø 2,5 mm	10
19689	Ø 2,6 mm	10
19690	Ø 2,7 mm	10
19691	Ø 2,8 mm	10
19692	Ø 2,9 mm	10
19693	Ø 3,0 mm	10

Č.p.	špecifikácia	
19694	Ø 3,1 mm	10
19695	Ø 3,2 mm	10
19696	Ø 3,3 mm	10
19697	Ø 3,4 mm	10
19698	Ø 3,5 mm	10
19699	Ø 3,6 mm	10
19700	Ø 3,7 mm	10
19701	Ø 3,8 mm	10
19702	Ø 3,9 mm	10
19703	Ø 4,0 mm	10
19704	Ø 4,1 mm	10
19705	Ø 4,2 mm	10
19706	Ø 4,3 mm	10
19707	Ø 4,4 mm	10
19708	Ø 4,5 mm	10
19709	Ø 4,6 mm	10
19710	Ø 4,7 mm	10
19711	Ø 4,8 mm	10
19712	Ø 4,9 mm	10
19713	Ø 5,0 mm	10
19714	Ø 5,1 mm	10
19715	Ø 5,2 mm	10
19716	Ø 5,3 mm	10
19717	Ø 5,4 mm	10

Č.p.	špecifikácia		Č.p.	špecifikácia	
19718	Ø 5,5 mm	10	19760	Ø 9,7 mm	5
19719	Ø 5,6 mm	10	19761	Ø 9,8 mm	5
19720	Ø 5,7 mm	10	19762	Ø 9,9 mm	5
19721	Ø 5,8 mm	10	19763	Ø 10,0 mm	5
19722	Ø 5,9 mm	10	19764	Ø 10,1 mm	5
19723	Ø 6,0 mm	10	19765	Ø 10,2 mm	5
19724	Ø 6,1 mm	10	19766	Ø 10,3 mm	5
19725	Ø 6,2 mm	10	19767	Ø 10,4 mm	5
19726	Ø 6,3 mm	10	19768	Ø 10,5 mm	5
19727	Ø 6,4 mm	10	19769	Ø 10,6 mm	5
19728	Ø 6,5 mm	10	19770	Ø 10,7 mm	5
19729	Ø 6,6 mm	10	19771	Ø 10,8 mm	5
19730	Ø 6,7 mm	10	19772	Ø 11,0 mm	5
19731	Ø 6,8 mm	10	19773	Ø 11,2 mm	5
19732	Ø 6,9 mm	10	19774	Ø 11,3 mm	5
19733	Ø 7,0 mm	10	19775	Ø 11,4 mm	5
19734	Ø 7,1 mm	10	19776	Ø 11,5 mm	5
19735	Ø 7,2 mm	10	19777	Ø 11,6 mm	5
19736	Ø 7,3 mm	10	19778	Ø 11,7 mm	5
19737	Ø 7,4 mm	10	19779	Ø 11,8 mm	5
19738	Ø 7,5 mm	10	19780	Ø 11,9 mm	5
19739	Ø 7,6 mm	10	19781	Ø 12,0 mm	5
19740	Ø 7,7 mm	10	19782	Ø 12,2 mm	5
19741	Ø 7,8 mm	10	19783	Ø 12,5 mm	5
19742	Ø 7,9 mm	10	19784	Ø 12,8 mm	5
19743	Ø 8,0 mm	10	19785	Ø 12,9 mm	5
19744	Ø 8,1 mm	10	19786	Ø 13,0 mm	5
19745	Ø 8,2 mm	10	19787	Ø 13,2 mm R13	5
19746	Ø 8,3 mm	10	19788	Ø 13,5 mm R13	5
19747	Ø 8,4 mm	10	19789	Ø 14,0 mm R13	5
19748	Ø 8,5 mm	10	19790	Ø 14,5 mm R13	5
19749	Ø 8,6 mm	5	19791	Ø 15,0 mm R13	5
19750	Ø 8,7 mm	5	19792	Ø 15,5 mm R13	5
19751	Ø 8,8 mm	5	19793	Ø 16,0 mm R13	5
19752	Ø 8,9 mm	5	19794	Ø 16,5 mm R13	5
19753	Ø 9,0 mm	5	19795	Ø 17,0 mm R13	5
19754	Ø 9,1 mm	5	19796	Ø 17,5 mm R13	5
19755	Ø 9,2 mm	5	19797	Ø 18,0 mm R13	5
19756	Ø 9,3 mm	5	19798	Ø 18,5 mm R13	5
19757	Ø 9,4 mm	5	19799	Ø 19,0 mm R13	5
19758	Ø 9,5 mm	5	19800	Ø 19,5 mm R13	5
19759	Ø 9,6 mm	5	19801	Ø 20,0 mm R13	5

**FESTA****BOX S VYBRÚSENÝMI VRTÁKMI DO KOVU HSS 4341**W 4%, Mo 3%
Cr 4%, V 1%**HSS****DIN
338****ALU****900
MPa**

Č.p.	špecifikácia	
19802		1
90192	bez vrtákov	1

Č.p.	obsah sady	Č.p.	obsah sady
19673	Ø 1,00 mm 20x	19728	Ø 6,50 mm 20x
19678	Ø 1,50 mm 20x	19733	Ø 7,00 mm 10x
19683	Ø 2,00 mm 20x	19738	Ø 7,50 mm 10x
19688	Ø 2,50 mm 20x	19743	Ø 8,00 mm 10x
19693	Ø 3,00 mm 30x	19748	Ø 8,50 mm 10x
19695	Ø 3,20 mm 30x	19753	Ø 9,00 mm 10x
19698	Ø 3,50 mm 30x	19758	Ø 9,50 mm 10x
19701	Ø 3,80 mm 30x	19763	Ø 10,00 mm 10x
19703	Ø 4,00 mm 30x	19768	Ø 10,50 mm 10x
19705	Ø 4,20 mm 30x	19772	Ø 11,00 mm 10x
19708	Ø 4,50 mm 30x	19776	Ø 11,50 mm 10x
19711	Ø 4,80 mm 30x	19781	Ø 12,00 mm 10x
19713	Ø 5,00 mm 20x	19783	Ø 12,50 mm 10x
19718	Ø 5,50 mm 20x	19786	Ø 13,00 mm 5x
19723	Ø 6,00 mm 20x		

FESTA

VRTÁK DO KOVU HSS PREDĹŽENÝ

W 4%, Mo 3%
Cr 4%, V 1%

HSS

DIN
338



ALU



MOQ

Č.p.	špecifikácia		Č.p.	špecifikácia	
20220	Ø 2,0 mm x 85 mm	10	20255	Ø 5,5 mm x 139 mm	10
20225	Ø 2,5 mm x 95 mm	10	20260	Ø 6,0 mm x 139 mm	10
20230	Ø 3,0 mm x 100 mm	10	20270	Ø 7,0 mm x 156 mm	10
20235	Ø 3,5 mm x 110 mm	10	20280	Ø 8,0 mm x 165 mm	10
20240	Ø 4,0 mm x 119 mm	10	20290	Ø 9,0 mm x 175 mm	10
20245	Ø 4,5 mm x 126 mm	10	20296	Ø 10,0 mm x 184 mm	10
20250	Ø 5,0 mm x 132 mm	10			

VRTÁK DO KOVU HSS TIN

· titánový povrch pre zvýšenie výkonu a životnosti

TiN

HSS

DIN
338



ALU



Č.p.	špecifikácia		Č.p.	špecifikácia		Č.p.	špecifikácia	
20400	Ø 1,0 mm	1	20411	Ø 4,8 mm	1	20422	Ø 9,5 mm	1
20401	Ø 1,5 mm	1	20412	Ø 5,0 mm	1	20423	Ø 10,0 mm	1
20402	Ø 2,0 mm	1	20413	Ø 5,5 mm	1	20424	Ø 10,2 mm	1
20403	Ø 2,5 mm	1	20414	Ø 6,0 mm	1	20425	Ø 10,5 mm	1
20404	Ø 3,0 mm	1	20415	Ø 6,5 mm	1	20426	Ø 11,0 mm	1
20405	Ø 3,2 mm	1	20416	Ø 6,8 mm	1	20427	Ø 11,5 mm	1
20406	Ø 3,5 mm	1	20417	Ø 7,0 mm	1	20428	Ø 12,0 mm	1
20407	Ø 3,8 mm	1	20418	Ø 7,5 mm	1	20429	Ø 12,5 mm	1
20408	Ø 4,0 mm	1	20419	Ø 8,0 mm	1	20430	Ø 13,0 mm	1
20409	Ø 4,2 mm	1	20420	Ø 8,5 mm	1			
20410	Ø 4,5 mm	1	20421	Ø 9,0 mm	1			

VRTÁK DO KOVU HSS

HSS

DIN
338



ALU



MOQ

Č.p.	špecifikácia		Č.p.	špecifikácia	
19841	Ø 4,1 mm 5 ks	10			
19842	Ø 4,2 mm 5 ks	10			
19845	Ø 4,5 mm 5 ks	10			
19885	Ø 8,5 mm 1 ks	10			
19895	Ø 9,5 mm 1 ks	10			

**FESTA**

VRTÁKY VYBRÚSENÉ DO KOVU

W 9%, Mo 3%
Cr 4%, V 1% HSS DIN 338

13x

Č.p. špecifikácia
20333 Ø 1,5 - 6,5 mm

1

**FESTA**

VRTÁKY DO KOVU

W 4%, Mo 3%
Cr 4%, V 1% HSS DIN 338

13x

Č.p. špecifikácia
20336 Ø 1,5 - 6,5 mm

1

**FESTA**

VRTÁKY VYBRÚSENÉ DO KOVU

W 9%, Mo 3%
Cr 4%, V 1% HSS DIN 338

19x

Č.p. špecifikácia
20334 Ø 1,0 - 10,0 mm

20

**FESTA**

VRTÁKY DO KOVU

W 4%, Mo 3%
Cr 4%, V 1% HSS DIN 338

19x

Č.p. špecifikácia
20337 Ø 1,0 - 10,0 mm

20

**FESTA**

VRTÁKY VYBRÚSENÉ DO KOVU

W 9%, Mo 3%
Cr 4%, V 1% HSS DIN 338

25x

Č.p. špecifikácia
20335 Ø 1,0 - 13,0 mm

5

**FESTA**

VRTÁKY DO KOVU

W 4%, Mo 3%
Cr 4%, V 1% HSS DIN 338

25x

Č.p. špecifikácia
20338 Ø 1,0 - 13,0 mm

10

FESTA

SADA VRTÁKOV

TiN



9x



Č.p.	špecifikácia	
20317	Ø 5-6-8 mm	20

FESTA

VRTÁKY SO ŠESŤHRANNOU STOPKOU

1/4" HSS



7x



Č.p.	špecifikácia	
20316	Ø 1,5-2-3-4-5-5,5-6 mm	20

VRTÁKY DO KOVU

HSS DIN 338



19x



Č.p.	špecifikácia	
20305	Ø 1,0 - 13,0 mm	25

VRTÁKY DO KOVU

HSS DIN 338



25x



Č.p.	špecifikácia	
20311	Ø 1,0 - 13,0 mm	10

VRTÁKY DO KOVU

HSS DIN 338



13x



Č.p.	špecifikácia	
20300	Ø 1,5 - 6,5 mm	50

VRTÁKY DO KOVU

HSS DIN 338



19x



Č.p.	špecifikácia	
20310	Ø 1 - 13 mm	10



VRTÁKY DO KOVU

TiN HSS DIN 338

INOX ALU

19x



Č.p. 20320 špecifikácia Ø 1 - 10 x 0,5 mm

30



VRTÁKY DO KOVU

HSS DIN 338

ALU

19x



Č.p. 20321 špecifikácia Ø 1 - 10 x 0,5 mm

5

VRTÁKY DO KOVU

HSS DIN 338

ALU

19x



Č.p. 20315 špecifikácia Ø 1 - 10 mm

10



OSTRIČ VRTÁKOV

Č.p. 20380 špecifikácia pre Ø 3,5 - 10 mm

20

FESTA

VRTÁK STUPŇOVÝ TiN

TiN HSS



Č.p.	špecifikácia	
20489	Ø 4 - 12 mm 8 stupňů	20
20490	Ø 4 - 20 mm 9 stupňů	10
20491	Ø 5 - 35 mm 13 stupňů	10
20492	Ø 7 - 40,5 mm 13 stupňů	5

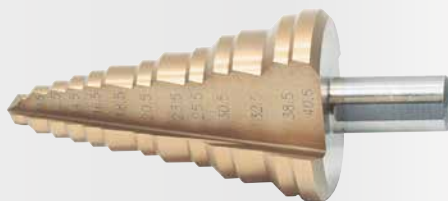

VRTÁK STUPŇOVÝ HSS

HSS



Č.p.	špecifikácia	
20487	Ø 4 - 20 mm 9 stupňů	10
20488	Ø 5 - 35 mm 13 stupňů	10
20494	Ø 4 - 32 mm 15 stupňů	10
20493	Ø 7 - 40,5 mm 13 stupňů	1

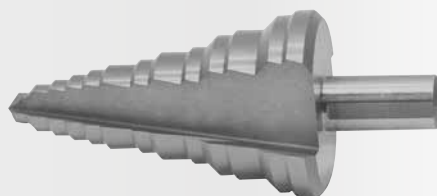

FESTA

SADA STUPŇOVITÝCH VRTÁKOV

TiN HSS



3x

Č.p.	špecifikácia	
20495	Ø 4 - 12, 4 - 20, 4 - 32 mm	1



SADA STUPŇOVITÝCH VRTÁKOV

HSS



3x

Č.p.	špecifikácia	
20496	Ø 4 - 12, 4 - 20, 4 - 32 mm	1



**FESTA**

VYKRUŽOVACIE KORUNKY HSS BI-METAL

HSS

Č.p.	špecifikácia	
24419	Ø 19 mm	1
24420	Ø 20 mm	1
24422	Ø 22 mm	1
24425	Ø 25 mm	1
24429	Ø 29 mm	1
24432	Ø 32 mm	1
24435	Ø 35 mm	1
24437	Ø 37 mm	1
24444	Ø 44 mm	1
24451	Ø 51 mm	1
24457	Ø 57 mm	1
24464	Ø 64 mm	1
24476	Ø 76 mm	1
24483	Ø 83 mm	1

**FESTA**

UNÁŠAČ PRE VYKRUŽOVACIE KORUNKY

Č.p.	špecifikácia	
24410	pre korunky 14 - 30 mm	1

**FESTA**

UNÁŠAČ PRE VYKRUŽOVACIE KORUNKY

Č.p.	špecifikácia	
24411	pre korunky 32 - 152 mm	1

NEW**FESTA**NÁHRADNÝ VRTÁK
PRE UNÁŠAČ PRE
VYKRUŽOVACIE KORUNKY

pre 24410, 24411

Č.p.	špecifikácia	
24412		5

**FESTA**

VYKRUŽOVACIE KORUNKY BI-METAL - SADA

HSS**9x**

Č.p.	špecifikácia	
24750	Ø 19, 22, 29, 38, 44, 57 mm	10

**FESTA**

VYKRUŽOVACIE KORUNKY BI-METAL - SADA

HSS**13x**

Č.p.	špecifikácia	
24751	Ø 19, 22, 29, 35, 38, 44, 51, 57, 64 mm	10



FESTA

VYŤAHOVÁK ZALOMENÝCH SKRUTIEK - SADA

- Ø 4 mm Ø 11 mm
- Ø 4,5 mm Ø 15 mm
- Ø 6,5 mm Ø 19 mm
- Ø 7,5 mm Ø 24 mm

8x



Č.p. špecifikácia

20387

5



FESTA

VYŤAHOVÁK ZALOMENÝCH SKRUTIEK - SADA

- Ø 4 mm
- Ø 4,5 mm
- Ø 6 mm
- Ø 7,5 mm
- Ø 11 mm

5x



Č.p. špecifikácia

20386

10



VYŤAHOVÁK ZALOMENÝCH SKRUTIEK - SADA

- Ø 4 mm
- Ø 4,5 mm
- Ø 6 mm
- Ø 7,5 mm
- Ø 11 mm

5x



Č.p. špecifikácia

20385

10



FESTA

DRŽIAK NA ZÁVITOVÉ OČKÁ

DIN 225



Č.p. špecifikácia

20396 25 x 9 mm

10



VRATIDLO RAČŇOVÉ NA ZÁVITNÍKY

Č.p. špecifikácia

20397 M3 - M8

10



FESTA

VRATIDLO NASTAVITEĽNÉ

DIN 1814



Č.p. špecifikácia

20395 1 - 1/2; M3 - M12

10



FESTA

ZÁVITNÍKY A ZÁVITOVÉ OČKÁ - SADA

32x



Č.p. špecifikácia

20391 M 3, 4, 5, 6, 8, 10, 12 mm

1



FESTA

VRATIDLO NASTAVITEĽNÉ

21x



Č.p. špecifikácia

20390 M 3, 4, 5, 6, 8, 10, 12 mm

1

FESTA**VRTÁK PRÍKLEPOVÝ VIDIOVÝ**

· dvojbritový vrták

**DIN
8039**

Č.p.	špecifikácia	A mm	B mm	
20673	Ø 3 mm	60	30	100
20674	Ø 4 mm	75	40	100
20675	Ø 5 mm	85	50	100
20676	Ø 6 mm	100	60	100
20677	Ø 6 mm	200	160	50
20685	Ø 6 mm	300	260	50
20678	Ø 8 mm	120	75	50
20686	Ø 8 mm	200	155	50

Č.p.	špecifikácia	A mm	B mm	
20687	Ø 8 mm	300	255	25
20688	Ø 8 mm	400	340	25
20680	Ø 10 mm	120	70	50
20690	Ø 10 mm	200	150	50
20691	Ø 10 mm	300	250	25
20692	Ø 10 mm	400	340	25
20682	Ø 12 mm	150	100	50
20694	Ø 12 mm	300	250	25

Č.p.	špecifikácia	A mm	B mm	
20696	Ø 12 mm	400	340	25
20684	Ø 14 mm	150	90	25
	redukce Ø 10 mm			
20697	Ø 14 mm	300	240	5
	redukce Ø 10 mm			
20698	Ø 14 mm	400	340	15
	redukce Ø 10 mm			

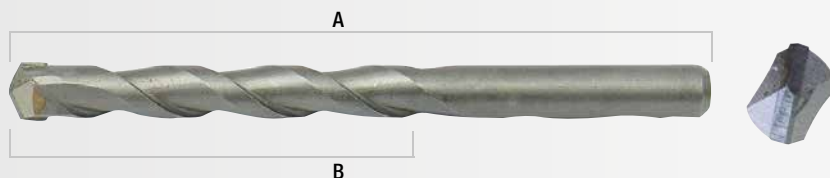
**FESTA****VRTÁK PRÍKLEPOVÝ VIDIOVÝ SDS+**

· dvojbritový vrták

SDS+

Č.p.	špecifikácia	A mm	B mm	
20855	Ø 14 mm	160	75	25

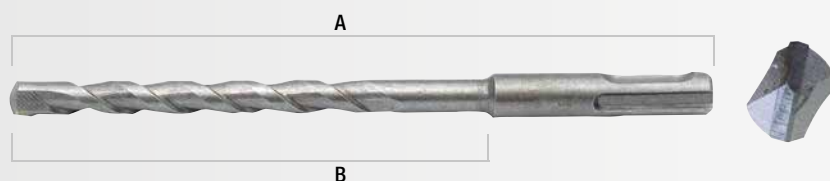
**FESTA****VRTÁK PRÍKLEPOVÝ VIDIOVÝ SDS+**

· štvorbritový vrták so zvýšenou výkonnosťou a trvanlivosťou

SDS+

Č.p.	špecifikácia	A mm	B mm	
20748	Ø 6 mm	110	40	50
20749	Ø 6 mm	160	90	50
20750	Ø 6 mm	210	140	50
20751	Ø 6 mm	260	190	50
20861	Ø 6,5 mm	230	160	50
20862	Ø 6,5 mm	300	230	50
20752	Ø 8 mm	110	40	50
20753	Ø 8 mm	160	90	50
20754	Ø 8 mm	210	140	50
20755	Ø 8 mm	260	190	50
20825	Ø 8 mm	350	280	50
20756	Ø 10 mm	160	90	50
20757	Ø 10 mm	210	140	50
20758	Ø 10 mm	260	190	50
20759	Ø 10 mm	350	280	50
20760	Ø 10 mm	450	380	50
20761	Ø 10 mm	600	530	50
20762	Ø 10 mm	1000	930	50
20764	Ø 12 mm	160	80	50
20765	Ø 12 mm	210	130	50
20766	Ø 12 mm	260	180	50
20767	Ø 12 mm	350	270	50

Č.p.	špecifikácia	A mm	B mm	
20768	Ø 12 mm	460	380	50
20769	Ø 12 mm	600	520	25
20770	Ø 12 mm	1000	920	25
20771	Ø 14 mm	160	80	25
20772	Ø 14 mm	260	180	25
20773	Ø 14 mm	350	270	25
20774	Ø 14 mm	460	380	25
20775	Ø 14 mm	600	520	25
20776	Ø 14 mm	1000	920	30
20777	Ø 16 mm	160	80	25
20778	Ø 16 mm	210	130	25
20779	Ø 16 mm	260	180	25
20780	Ø 16 mm	350	270	25
20781	Ø 16 mm	460	380	25
20782	Ø 16 mm	600	520	30
20783	Ø 16 mm	1000	920	25
20784	Ø 18 mm	260	180	25
20785	Ø 18 mm	450	370	25
20786	Ø 18 mm	600	520	32
20787	Ø 18 mm	1000	920	20
20788	Ø 20 mm	450	370	20
20789	Ø 20 mm	600	520	20

Č.p.	špecifikácia	A mm	B mm	
20790	Ø 20 mm	800	720	25
20791	Ø 20 mm	1000	920	10
20792	Ø 22 mm	450	365	20
20793	Ø 22 mm	600	520	20
20794	Ø 22 mm	800	715	20
20795	Ø 22 mm	1000	920	10
20796	Ø 24 mm	450	365	10
20797	Ø 24 mm	600	520	20
20798	Ø 24 mm	800	715	10
20799	Ø 24 mm	1000	920	10
20870	Ø 26 mm	450	370	10
20871	Ø 26 mm	650	570	20
20872	Ø 26 mm	800	720	10
20873	Ø 26 mm	1000	920	10
20874	Ø 28 mm	450	365	10
20875	Ø 28 mm	600	565	20
20876	Ø 28 mm	800	715	10
20877	Ø 28 mm	1000	915	10
20878	Ø 30 mm	450	365	10
20879	Ø 30 mm	600	565	20
20880	Ø 30 mm	800	715	10
20881	Ø 30 mm	1000	915	10

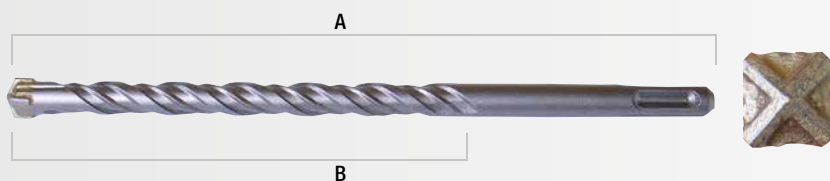

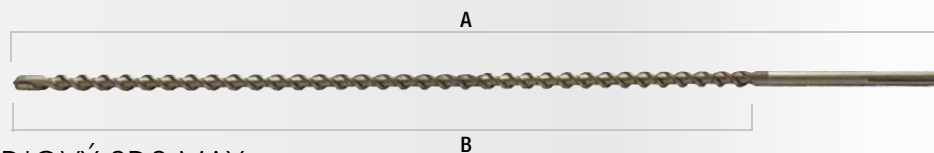

FESTA

VRTÁK PRÍKLEPOVÝ VIDIOVÝ SDS MAX

štvorbřitový vrták so zvýšenou výkonnosťou a trvanlivosťou

SDS MAX



Č.p.	špecifikácia	A mm	B mm		Č.p.	špecifikácia	A mm	B mm		Č.p.	špecifikácia	A mm	B mm	
20508	NEW Ø 16 mm	550	395	5	20512	Ø 22 mm	550	395	5	20524	Ø 28 mm	800	650	5
20510	Ø 18 mm	550	395	5	20522	Ø 22 mm	800	650	5	20515	Ø 30 mm	550	395	5
20520	Ø 18 mm	800	650	5	20513	Ø 24 mm	550	395	5	20525	Ø 30 mm	800	650	5
20511	Ø 20 mm	550	395	5	20523	Ø 24 mm	800	650	5	20516	Ø 40 mm	550	395	2
20521	Ø 20 mm	800	650	5	20514	Ø 28 mm	550	395	5	20526	Ø 40 mm	800	650	1



STOJAN PREZENTAČNÝ

Č.p. špecifikácia

20999



1

SADA VRTÁKOV DO MURIVA SDS +

SDS+

5x



Č.p.	špecifikácia	
20890	Ø 5, 6, 8, 10, 12 mm 160 mm	25

SADA VRTÁKOV DO MURIVA SDS +

SDS+

6x



Č.p.	špecifikácia	
20891	Ø 5, 6, 8 mm 110 mm Ø 8, 10, 12 mm 160 mm	25

SADA VRTÁKOV DO MURIVA

DIN 8039

6x



Č.p.	špecifikácia	
20895	Ø 5, 6, 8, 10, 12 mm	25

SADA VRTÁKOV DO MURIVA



Č.p.	špecifikácia	
20805	5 ks Ø 4 - 10 mm	10
20820	8 ks Ø 3 - 10 mm	10

FESTA**SEKÁČE A VRTÁKY SDS+**

- 2 x špičák
- 3 x sekáč
- 12 x vrták

SDS+



17x

Č.p. špecifikácia

20952



1

**FESTA****SEKÁČE A VRTÁKY SDS+**

- 1 x špičák 250 mm
- 1 x dutý 22 x 250 mm
- 1 x plochý 20 x 250 mm

- Ø 5 x 110 mm
- Ø 6 x 110 mm
- Ø 8 x 160 mm
- Ø 10 x 160 mm
- Ø 12 x 160 mm
- Ø 14 x 210 mm
- Ø 16 x 210 mm
- Ø 18 x 310 mm
- Ø 20 x 450 mm

SDS+



12x

Č.p. špecifikácia

20950

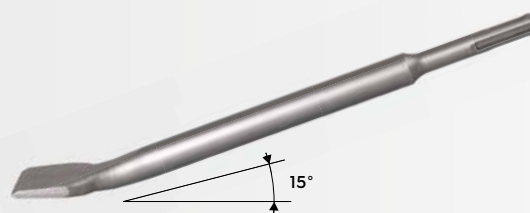

5

**FESTA****SEKÁČE SADA**

SDS+

4x

Č.p. špecifikácia

20954

250 mm



1

FESTA**SEKÁČ PLOCHÝ, ZAHNUTÝ 15°**

SDS+

Č.p.

20936

špecifikácia

40 x 250 mm



5



FESTA

SEKÁČ

SDS
MAX



Č.p.	špecifikácia	
20940	25 x 280 mm	5
20941	40 x 280 mm	5
20942	75 x 280 mm	5
20943	25 x 400 mm	5
20944	40 x 400 mm	5
20945	25 x 600 mm	5
20946	50 x 600 mm	5



FESTA

SEKÁČ

SDS+



Č.p.	špecifikácia	
20948	20 x 250 mm	25
20990	20 x 400 mm	25
20949	40 x 250 mm	25
20991	40 x 400 mm	25



FESTA

SEKÁČ ŠPICATÝ

SDS
MAX



Č.p.	špecifikácia	
20937	Ø 18 x 280 mm	5
20938	Ø 18 x 400 mm	5
20939	Ø 18 x 600 mm	2



FESTA

SEKÁČ ŠPICATÝ

SDS+



Č.p.	špecifikácia	
20947	250 mm	25
20992	400 mm	25



FESTA

STOPKA UPÍNACIA PRE
VYKRUŽOVACIE KORUNKY

SDS
MAX



Č.p.	špecifikácia	
24730	180 mm	1



FESTA

STOPKA UPÍNACIA PRE
VYKRUŽOVACIE KORUNKY

SDS+



Č.p.	špecifikácia	
24731	300 mm	1
24732		1



FESTA

DRÁŽKOVAC

SDS+



Č.p.	špecifikácia	
20956	22 x 250 mm	25



FESTA

ADAPTÉR SDS+ NA BIT 1/4"

SDS+



Č.p.	špecifikácia	
20743	75 mm	1



ADAPTÉR SDS MAX NA SDS+

SDS
MAX

SDS+



Č.p.	špecifikácia	
20744		1

**FESTA****KORUNKA VYKRUŽOVACIA S SK PLÁTKAMI**

stopka upínacia pre vykrúžovacia korunky 24730, 24731 a 24732

SDS+



Č.p.	špecifikácia	
24719	Ø 67 mm	1
24717	Ø 73 mm	1
24723	Ø 80 mm	1
24718	Ø 100 mm	1
24757	Ø 115 mm	1
24758	Ø 125 mm	1
24759	Ø 150 mm	1

**VYKRUŽOVÁK**

Č.p.	špecifikácia	
24725	Ø 20-95mm	10

**VYKRUŽOVÁK S KRYTOM**

Č.p.	špecifikácia	
24726	Ø 20-95mm	1

**FESTA****VYKRUŽOVACIE KORUNKY - SADA**

8x

Č.p.	špecifikácia	
24747	Ø 33, 53, 67, 73, 83 mm unašeč, vrták, pilník	1

**FESTA****KORUNKY VYKRUŽOVACIE - SADA**

6x

Č.p.	špecifikácia	
24745	Ø 33, 53, 67, 73 mm + unašeč, vrták	1

FESTA

KORUNKA VYKRUŽOVACIA



Č.p.	špecifikácia	
24735	Ø 33 mm	1
24736	Ø 43 mm	1
24737	Ø 53 mm	1
24738	Ø 67 mm	1
24739	Ø 73 mm	1
24740	Ø 83 mm	1
24741	Ø 103 mm	1



FESTA

KORUNKA VYKRUŽOVACIA NA DLAŽBU - SADA

3x



Č.p.	špecifikácia	
24746	Ø 103 mm + unašeč, vrták	1



FESTA

UNÁŠAČ PRE VYKRUŽOVACIE KORUNKY



Č.p.	špecifikácia	
24748	Ø 33 - 83 mm	10
24743	Ø 33 - 103 mm	10

FESTA

VRTÁK PRE VYKRUŽOVACIE KORUNKY



Č.p.	špecifikácia	
24749		50



PILNÍK NA OBKLADY A DLAŽBU



Č.p.	špecifikácia	
22200	200 mm	20



PILNÍK PLOCHÝ NA OBKLADY, DLAŽBU A MURIVO

· pre brúsenie tehál pred vloženíím stenové kotvy



Č.p.	špecifikácia	
22201	200 mm dvojí hrúbosť	20



FESTA

KORUNKA VRTACIA KARBIDOVÁ

· Pre vrtanie do skla a keramiky
· Nutné chladienie



Č.p.	špecifikácia	
24770	Ø 4 mm	1
24771	Ø 6 mm	1
24772	Ø 8 mm	1
24773	Ø 10 mm	1
24774	Ø 12 mm	1



VODIČ NA VRTÁKY A VRTACIE KORUNKY

Č.p.	špecifikácia	
20379	Ø 4, 5, 6, 7, 8, 10, 12 mm	10





NEW



FESTA

KORUNKA VYKRUŽOVACIA DIAMANTOVÁ

M14



- keramické obklady
- mramor
- žula



- Použitie bez chladenia vodou



Č.p.	špecifikácia	úchyt	
24760	Ø 6 mm	M14	1
24761	Ø 8 mm	M14	1
24762	Ø 10 mm	M14	1
24763	Ø 12 mm	M14	1
24764	Ø 14 mm	M14	1
24670	Ø 16 mm	M14	1
24671	Ø 18 mm	M14	1
24790	Ø 20 mm	M14	1
24672	Ø 22 mm	M14	1
24673	Ø 25 mm	M14	1
24765	Ø 28 mm	M14	1
24674	Ø 30 mm	M14	1

Č.p.	špecifikácia	úchyt	
24675	Ø 32 mm	M14	1
24766	Ø 35 mm	M14	1
24776	Ø 40 mm	M14	1
24767	Ø 45 mm	M14	1
24791	Ø 50 mm	M14	1
24768	Ø 53 mm	M14	1
24792	Ø 60 mm	M14	1
24793	Ø 65 mm	M14	1
24769	Ø 68 mm	M14	1
24794	Ø 75 mm	M14	1
24796	Ø 83 mm	M14	1
24676	Ø 110 mm	M14	1

FESTA

KORUNKY VYKRUŽOVACIE DIAMANTOVÉ, SADA

- Ø 8 mm
- Ø 10 mm
- Ø 14 mm
- Ø 22 mm
- Ø 32 mm
- Ø 40 mm
- Ø 68 mm

7x M14



- keramické obklady
- mramor
- žula



- Použitie bez chladenia vodou



Č.p.	špecifikácia	
24650		1



FESTA

KORUNKA VYKRUŽOVACIA DIAMANTOVÁ



- keramické obklady
- mramor
- žula



Č.p.	špecifikácia	
24700	Ø 6 mm	1
24701	Ø 8 mm	1
24702	Ø 10 mm	1
24703	Ø 12 mm	1
24704	Ø 14 mm	1
24705	Ø 20 mm	1

FESTA

KORUNKA VYKRUŽOVACIA DIAMANTOVÁ

6x



- keramické obklady
- mramor
- žula



Č.p.	špecifikácia	
24798	Ø 6, 8, 10, 12, 14, 20 mm	1

NEW

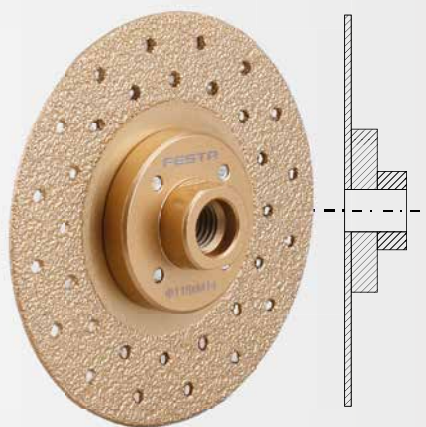

FESTA
KOTÚČ REZNÝ
A BRÚSNÝ
DIAMANTOVÝ

M14



· Použitie bez chladenia vodou

Č.p.	Špecifikácia	
24655	Ø 115 mm M14	1

NEW

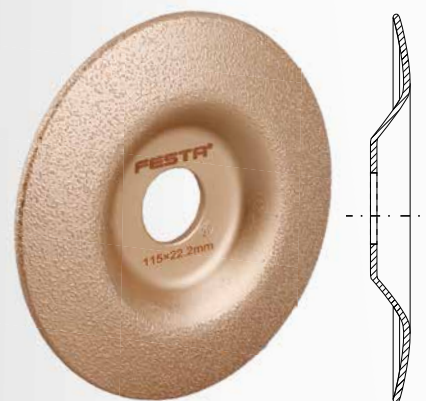

FESTA
KOTÚČ BRÚSNÝ
DIAMANTOVÝ



· Použitie bez chladenia vodou

Č.p.	Špecifikácia	
24658	Ø 115 mm Ø 22,2 mm	1

NEW

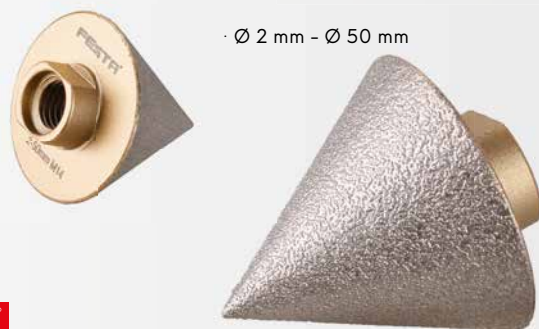

· Ø 2 mm - Ø 50 mm

FESTA
KORUNKA BRÚSNA
DIAMANTOVÁ

M14



· keramické obklady
· mramor
· žula



· Použitie bez chladenia vodou

Č.p.	Špecifikácia	
24778	Ø 2 - 50 mm	1

NEW



· Ø 20 mm - Ø 48 mm

FESTA
KORUNKA BRÚSNA
DIAMANTOVÁ

M14



· keramické obklady
· mramor
· žula



· Použitie bez chladenia vodou

Č.p.	Špecifikácia	
24779	Ø 20 - 48 mm	1

FESTA
KORUNKA BRÚSNA
DIAMANTOVÁ

M14



· keramické obklady
· mramor
· žula



· Použitie bez chladenia vodou

Č.p.	Špecifikácia	
24795	Ø 20 x 50 mm	1

FESTA
VRTÁK NA SKLO A
KERAMIKU

TiN





1/4"



Č.p.	Špecifikácia	
24780	Ø 4 mm	10
24781	Ø 5 mm	40
24782	Ø 6 mm	40
24783	Ø 8 mm	40
24784	Ø 10 mm	40
24785	Ø 12 mm	40
24786	Ø 14 mm	1
24787	Ø 16 mm	1
24788	Ø 18 mm	1
24789	Ø 20 mm	1

**FESTO****SEKÁČE, JAMKÁRE, PRIEBOJNÍKY - SADA****CrV****12x**



-  2, 6, 8 mm
-  10, 12, 16 mm
-  Ø 1,5-3-4-5-6-8 mm



Č.p.	špecifikácia
19487	

4

**FESTO****SEKÁČE, JAMKÁRE, PRIEBOJNÍKY - SADA****CrV****6x**

-  2 x 140, 8 x 115 mm
-  12 x 152, 10 x 142 mm
-  Ø 3 x 152, 6 x 152 mm



Č.p.	špecifikácia
19486	

10

**FESTO****SEKÁČ ZÁMOČNÍCKY KRÍŽOVÝ****CrV**

Č.p.	špecifikácia
19429	200 mm

1

**FESTO****SEKÁČE - SADA****CrV****3x**

-  10, 12, 16 mm



Č.p.	špecifikácia
19485	

10

**FESTO****SEKÁČ PLOCHÝ****CrV**

Č.p.	špecifikácia		
19410	200 mm	20 mm	10
19411	250 mm	25 mm	10
19412	300 mm	25 mm	10
19418	400 mm	25 mm	5
19419	500 mm	25 mm	5

**SEKÁČ ZÁMOČNÍCKY PLOCHÝ****CrV**

Č.p.	špecifikácia		
19436	200 mm	20 mm	15



FESTA

PRIEBOJNÍKY - SADA

CrV 6x

Č.p.	špecifikácia	
19483	Ø 3, 4, 5, 6, 7, 8 mm	5



FESTA

PRIEBOJNÍKY - SADA

CrV 6x

Č.p.	špecifikácia	
19482	Ø 3, 4, 5, 6, 8 mm	5



FESTA

PRIEBOJNÍK

CrV

Č.p.	špecifikácia	
19472	Ø 4 mm 150 mm	1
19473	Ø 5 mm 150 mm	1
19474	Ø 6 mm 150 mm	1



FESTA

PRIEBOJNÍKY - SADA

CrV 3x

Č.p.	špecifikácia	
19480	Ø 0.8, 1.5, 2.5 mm	10



FESTA

JAMKÁR

CrV

Č.p.	špecifikácia	
19477	Ø 2,5 mm	20



FESTA

JAMKÁRE - SADA

CrV 3x

Č.p.	špecifikácia	
19481	Ø 0.8, 1.5, 2.5 mm	10



FESTA

JAMKÁR AUTOMATICKÝ

CrV

Č.p.	špecifikácia	
19478	Ø 2,5 mm	12



REZAČ SKLA



Č.p.	špecifikácia	
20350	130 mm	12

**FESTA**

VRTÁK HADOVITÝ DO DREVA



Č.p.	špecifikácia		Č.p.	špecifikácia	
20980	Ø 6 x 230 mm	1	20984	Ø 16 x 230 mm	1
20957	Ø 6 x 300 mm	1	20899	Ø 16 x 300 mm	1
20981	Ø 8 x 230 mm	1	20917	Ø 16 x 450 mm	1
20958	Ø 8 x 300 mm	1	20922	Ø 16 x 600 mm	1
20982	Ø 10 x 230 mm	1	20918	Ø 18 x 450 mm	1
20896	Ø 10 x 300 mm	1	20923	Ø 18 x 600 mm	1
20913	Ø 10 x 450 mm	1	20919	Ø 20 x 450 mm	1
20983	Ø 12 x 230 mm	1	20924	Ø 20 x 600 mm	1
20897	Ø 12 x 300 mm	1	20724	Ø 22 x 450 mm	1
20915	Ø 12 x 450 mm	1	20725	Ø 24 x 450 mm	1
20920	Ø 12 x 600 mm	1	20726	Ø 26 x 450 mm	1
20898	Ø 14 x 300 mm	1	20727	Ø 28 x 450 mm	1
20916	Ø 14 x 450 mm	1	20728	Ø 30 x 450 mm	1
20921	Ø 14 x 600 mm	1			

**FESTA**

VRTÁKY HADOVITÉ DO DREVA - SÚPRAVA

**5x**

Č.p.	špecifikácia	
20911	Ø 8, 10, 12, 14, 16 x 460 mm	10

**FESTA**

VRTÁKY HADOVITÉ DO DREVA - SÚPRAVA

**6x**

Č.p.	špecifikácia	
20912	Ø 6, 8, 10, 12, 16, 20 x 230 mm	10



VRTÁK DO DREVA



Č.p.	špecifikácia		Č.p.	špecifikácia		Č.p.	špecifikácia	
20729	Ø 6 x 400 mm	1	20732	Ø 12 x 400 mm	1	20734	Ø 16 x 400 mm	1
20731	Ø 8 x 400 mm	1	20738	Ø 12 x 600 mm	1	20740	Ø 16 x 600 mm	1
20736	Ø 8 x 600 mm	1	20733	Ø 14 x 400 mm	1	20735	Ø 18 x 400 mm	1
20730	Ø 10 x 400 mm	1	20739	Ø 14 x 600 mm	1	20741	Ø 18 x 600 mm	1
20737	Ø 10 x 600 mm	1						



VRTÁK DO DREVA



Č.p.	špecifikácia	
21440	Ø 4 x 75 mm	1
21441	Ø 5 x 85 mm	1
21442	Ø 6 x 90 mm	1
21443	Ø 7 x 105 mm	1
21444	Ø 8 x 115 mm	1
21445	Ø 9 x 120 mm	1
21446	Ø 10 x 120 mm	1

VRTÁKY DO DREVA - SÚPRAVA



Č.p.	špecifikácia	
20910	8 ks Ø 3, 4, 5, 6, 7, 8, 9, 10 mm	10
20905	5 ks Ø 4, 5, 6, 8, 10 mm	10



VRTÁK FRÉZOVACÍ

HSS TiN



Č.p. 20460 špecifikácia Ø 6 mm 50

FESTA

VRTÁK NA KONFIRMÁTY - VYBRÚSENÝ

HSS

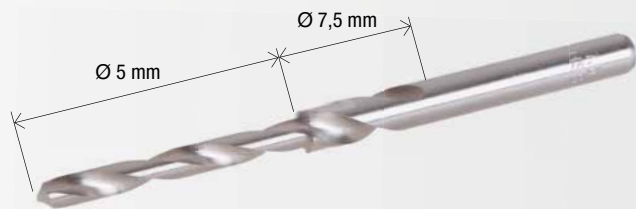

Č.p. 20210 špecifikácia Ø 7,5, 5 mm 1

VRTÁKY FRÉZOVACIE - SADA

HSS TiN



6x



Č.p. 20450 špecifikácia Ø 3, 4, 5, 6, 6.5, 8 mm 20

VRTÁKY DO DREVA - SÚPRAVA



6x



Č.p. 20901 špecifikácia Ø 10, 12, 16, 18, 20, 25 mm 20

SUKOVNÍKY - SADA



5x



Č.p. 21530 špecifikácia Ø 15, 20, 25, 30, 35 mm Ø 8 mm 20

TVAROVÉ FRÉZY DO DREVA



5x



Č.p. 21450 špecifikácia Ø 8 mm 1

TVAROVÉ FRÉZY DO DREVA



12x



Č.p. 21451 špecifikácia Ø 8 mm 1

TVAROVÉ FRÉZY DO DREVA



24x



Č.p. 21452 špecifikácia Ø 8 mm 1



TVAROVÉ FRÉZY DO DREVA

35x

Č.p. 21453 špecifikácia Ø 8 mm



1



TVAROVÉ FRÉZY DO DREVA

59x

Č.p. 21454 špecifikácia Ø 8 mm



1



ROTAČNÉ RAŠPLE

6 mm  12 mm

5x

Č.p. 21541 špecifikácia



25



ROTAČNÉ BRÚSKY

5x

Č.p. 21540 špecifikácia Ø 3 mm, 6 mm



12



NADSTAVCE NA PRIAMU BRÚSKU

100x

Č.p. 24755 špecifikácia



5



NADSTAVCE NA PRIAMU BRÚSKU

150x

Č.p. 24756 špecifikácia

10

NEW



· Ø 19 - 127 mm

FESTA

KORUNKA VYKRUŽOVACIA - NASTAVITEĽNÁ



Č.p.	Špecifikácia		
24415	Ø 19 - 127 mm	max. hĺbka 29 mm	6

FESTA

PÍLY VYKRUŽOVACIE

- Ø 19 mm
- Ø 22 mm
- Ø 25,5 mm
- Ø 36 mm
- Ø 44 mm

- Ø 51 mm
- Ø 60 mm
- Ø 67 mm
- Ø 76 mm
- Ø 82 mm
- inbus
- 2x hlavička



12x	Č.p.	Špecifikácia	
	24712	6 tpi	20

FESTA

PÍLY VYKRUŽOVACIE

- Ø 64 mm
- Ø 73 mm
- Ø 89 mm
- Ø 102 mm
- Ø 127 mm
- inbus
- hlavička



8x	Č.p.	Špecifikácia	
	24706	6 tpi	20

**FESTA**

VYKRUŽOVACIA PÍLA NA DREVO A SA-DROKARTON



Č.p.	špecifikácia	
24715	1' Ø 67 mm 6 tpi	5
24713	1' Ø 73 mm 6 tpi	5
24714	1' Ø 102 mm 6 tpi	5
24720	1' Ø 152 mm 6 tpi	5

PÍLY VYKRUŽOVACIE



Č.p.	špecifikácia	
24721	1' Ø 26, 32, 38, 45, 50, 56, 63 mm	10
24722	2' Ø 26, 32, 38, 45, 50, 56, 63 mm	10



VYKRUŽOVÁK NASTAVITEĽNÝ



Č.p.	špecifikácia	
24716	Ø 30 - 120 mm	5

NEBOŽIECE - SADA

HOBBY**4x**

Č.p.	špecifikácia	
20381	Ø 2, 3, 4, 5 mm	20



ADAPTÉR SDS MAX NA SDS +



Č.p.	špecifikácia	
20744		1

ADAPTÉR SDS +

SDS+

Č.p.	špecifikácia	
20745		1



FESTA

SKĽUČOVADLO

1/2"



Č.p.	špecifikácia	
20960	1-13 mm + 2 kľúče, 1/2 - 20 UNF	3
20966	náhradný kľúčik	25



FESTA

SKĽUČOVADLO RÝCHLOUPÍNACIE

1/2"



Č.p.	špecifikácia	
20965	1,5 - 13 mm 1/2' - 20 UNF	1



SKĽUČOVADLO RÝCHLOUPÍNACIE

1/2"



Č.p.	špecifikácia	
20961	1,5 - 13 mm 1/2' - 20 UNF	1



NADSTAVEC NA VRTANIE 90°

Č.p.	špecifikácia	
20365	Ø 1,0 - 10 mm	10



SKĽUČOVADLO RÝCHLOUPÍNACIE DO AKU

1/4"



Č.p.	špecifikácia	
20963	Ø 1 - 6 mm	10



RAZNICA ČÍSLA

Č.p.	špecifikácia	
20972	6 mm	5
20973	8 mm	5



VÝSEČNÍKY

13x



Č.p.	špecifikácia	
24695	Ø 5, 6, 8, 10, 11, 13, 16, 19, 22, 25, 28, 32, 35 mm	5



DIEROVAČE

24690 - Ø 2,5 mm	24691 - Ø 2 mm
Ø 3 mm	Ø 2,5 mm
Ø 4 mm	Ø 3,2 mm
Ø 5 mm	Ø 4 mm
Ø 6 mm	Ø 4,8 mm
Ø 7 mm	Ø 5 mm
Ø 8 mm	Ø 6,4 mm
Ø 9 mm	Ø 8 mm
Ø 10 mm	Ø 9,5 mm
	Ø 11,1 mm
	Ø 12,7 mm
	Ø 14 mm
	Ø 15,8 mm
	Ø 19 mm
	Ø 22 mm

Č.p.	špecifikácia	
24690	9 ks Ø 2,5 - 10 mm	10
24691	15 ks Ø 2 - 22 mm	5



RAZNICA ABECEDY

Č.p.	špecifikácia	
20970	6 mm	5
20971	8 mm	5

FESTA®**KEFY**

20mm

FESTA®**KEFA MISKOVÁ, VLNITÁ**

· pomasadený

M14

Č.p.	špecifikácia	drôt	
21900	Ø 100 mm M14	s 0,3	60
21902	Ø 125 mm M14	s 0,3	42



10mm

FESTA®**KEFA MISKOVÁ, VLNITÁ**

· pomasadený

M14

Č.p.	špecifikácia	drôt	
22001	Ø 100 mm M14	s 0,3	60
21901	Ø 125 mm M14	s 0,3	42

**FESTA®****KEFA MISKOVÁ, VLNITÁ**

· mosadzný

M14

Č.p.	špecifikácia	drôt	
21920	Ø 100 mm M14	s 0,3	60

**FESTA®****KEFA HRNČEKOVÁ, VLNITÁ**

· pomasadený

M14

Č.p.	špecifikácia	drôt	
21903	Ø 65 mm M14	s 0,3	60
22002	Ø 75 mm M14	s 0,3	80
21904	Ø 85 mm M14	s 0,3	60
22003	Ø 100 mm M14	s 0,3	36
21905	Ø 125 mm M14	s 0,3	24
21906	Ø 150 mm M14	s 0,3	12

**FESTA®****KEFA HRNČEKOVÁ, VLNITÁ**

· mosadzný

M14

Č.p.	špecifikácia	drôt	
21925	Ø 75 mm M14	0,3 mm	80
21926	Ø 100 mm M14	0,3 mm	36

**FESTA®****KEFA OKRUŽNÁ, VLNITÁ**

· pomasadený

· redukčné krúžky

M14

Č.p.	špecifikácia	drôt	
22007	Ø 100 mm Ø 20 mm	s 0,3	60
22008	Ø 125 mm Ø 20 mm	s 0,3	42
22009	Ø 150 mm Ø 32,2 mm	s 0,3	32
22010	Ø 175 mm Ø 32,2 mm	s 0,3	20
22011	Ø 200 mm Ø 32,2 mm	s 0,3	20



FESTA

KEFA HRNČEKOVÁ, COPY

· patentované

M14



Č.p.	špecifikácia	drôt	
22004	Ø 65 mm M14	s 0,3	60
22005	Ø 75 mm M14	s 0,3	24
22006	Ø 100 mm M14	s 0,3	24
21907	Ø 125 mm M14	s 0,3	24
21908	Ø 150 mm M14	s 0,3	12



FESTA

KEFA HRNČEKOVÁ, COPY

· patentované

INOX M14



Č.p.	špecifikácia	drôt	
22037	Ø 65 mm M14	s 0,5	60
22038	Ø 80 mm M14	s 0,5	24



FESTA

KEFA RADIÁLNA, COPY

· patentované

M14



Č.p.	špecifikácia	drôt	počet copů	
21911	Ø 100 mm M14	s 0,5	30	60
21912	Ø 115 mm M14	s 0,5	32	42
21913	Ø 125 mm M14	s 0,5	36	42
21914	Ø 150 mm M14	s 0,5	40	32



FESTA

KEFA RADIÁLNA, COPY

· patentované

M14



Č.p.	špecifikácia	drôt	
22012	Ø 100 mm M14	s 0,5	60
22013	Ø 115 mm M14	s 0,5	42
22014	Ø 125 mm M14	s 0,5	42
22015	Ø 150 mm M14	s 0,5	32
22016	Ø 178 mm M14	s 0,5	20



FESTA

KEFA RADIÁLNA, COPY

· patentované

INOX M14



Č.p.	špecifikácia	drôt	
22039	Ø 100 mm M14	s 0,5	60
22040	Ø 125 mm M14	s 0,5	42



FESTA

KEFA MISKOVÁ, COPY

· patentované

M14



Č.p.	špecifikácia	drôt	
22017	Ø 100 mm M14	s 0,5	60
21909	Ø 115 mm M14	s 0,5	42
21910	Ø 125 mm M14	s 0,5	42



Ø 6 mm

FESTA

KEFA OKRUŽNÁ, COPY, STOPKA

· patentované



Č.p.	špecifikácia	drôt	
22023	Ø 75 mm	s 0,5	10



Ø 6 mm

FESTA

KEFA HRNČEKOVÁ, COPY, STOPKA

· patentované



Č.p.	špecifikácia	drôt	
22024	Ø 75 mm	s 0,5	12



Ø 6 mm

FESTA

KEFA MISKOVÁ, COPY, STOPKA

· patentované



Č.p.	špecifikácia	drôt	
22025	Ø 75 mm	s 0,5	12

**FESTA**KEFA OKRUŽNÁ, VLNITÁ,
POMOSADZENÁ

pomosadený

Č.p.	špecifikácia	drôt	
22026	Ø 50 mm	s 0,3	15
22027	Ø 63 mm	s 0,3	15
22028	Ø 75 mm	s 0,3	10
22029	Ø 100 mm	s 0,3	15

**FESTA**KEFA HRNČEKOVÁ, VLNITÁ,
POMOSADZENÁ

pomosadený

Č.p.	špecifikácia	drôt	
22030	Ø 65 mm	s 0,3	12
22031	Ø 75 mm	s 0,3	12

**FESTA**KEFA KONCOVÁ, COPY,
STOPKA

patentované

Č.p.	špecifikácia	drôt	
22021	Ø 19 mm	s 0,5	30
22022	Ø 22 mm	s 0,5	25

**FESTA**KEFA KONCOVÁ, VLNITÁ,
STOPKA

Č.p.	špecifikácia	drôt	
22058	Ø 12 mm	s 0,3	25
22059	Ø 25 mm	s 0,3	25

**FESTA**KEFA KONCOVÁ, VLNITÁ,
POMOSADZENÁ

pomosadený

Č.p.	špecifikácia	drôt	
22018	Ø 12 mm	s 0,3	15
22019	Ø 17 mm	s 0,3	15
22020	Ø 25 mm	s 0,3	25

**FESTA**

KEFA OKRUŽNÁ, NYLONOVÁ

Č.p.	špecifikácia	drôt	
21930	Ø 125 mm M14	1,2 mm	10
21931	Ø 150 mm M14	1,2 mm	15

**FESTA**KEFA HRNČEKOVÁ, VLNITÁ,
NYLONOVÁ

Č.p.	špecifikácia	drôt	
21940	Ø 75 mm M14	1,2 mm	1
21941	Ø 100 mm M14	1,2 mm	1

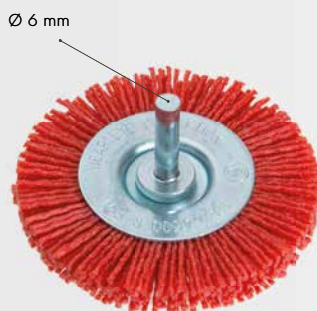
**FESTA**KEFA OKRUŽNÁ,
NYLONOVÁ, STOPKA

Č.p.	špecifikácia	drôt	
21935	Ø 50 mm	1,2 mm	1
21936	Ø 75 mm	1,2 mm	1
21937	Ø 100 mm	1,2 mm	1

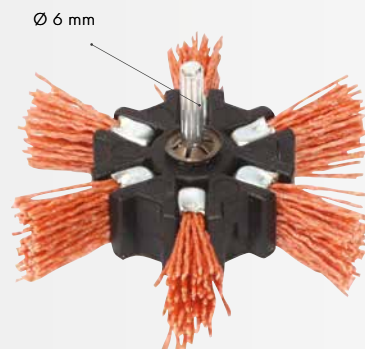
**FESTA**KEFA OKRUŽNÁ,
NYLONOVÁ, STOPKA

Č.p.	špecifikácia	drôt	
22032	Ø 100 mm	1,2 mm	12



ŠTETEC DRÔTENÝ

Č.p.	špecifikácia	drôt	
22158	200 mm	ocel	1
22159	200 mm	mosaz	1



KEFA VLNITÁ

Č.p.	špecifikácia	drôt	
22035	270 mm	ocel	24
22036	270 mm	nerex	24



KEFA OCEĽOVÁ

Č.p.	špecifikácia	rady	
22033	300 mm	4 rady	12
22034	300 mm	5 rád	12



KEFA POMOSADZENÁ

Č.p.	rady	
22078	3 rady	20



KEFA POMOSADZENÁ pomosazený

Č.p.	špecifikácia	rady	
22079	300 mm	4 rady	6



FESTA

KEFA OCEĽOVÁ

Č.p.	špecifikácia	rady	
22080	270 mm	5 rád	12



FESTA

KEFA MOSADZNÁ

Č.p.	špecifikácia	rady	
22082	300 mm	5 rád	12



KEFY OCEĽOVÉ, POMOSADZENÉ - SADA

3x

Č.p.	rady	
22081	3 rady	12



FESTA

KEFY - SADA

· nylon, nerex, mosadz

3x

Č.p.	špecifikácia	
22086	180 mm	12

**FESTA**

KOTUČ DIAMANTOVÝ LEŠTIACI Ø 100 MM, SO SUCHÝM ZIPSOM

- keramické obklady
- sklo
- mramor
- žula



Č.p.	hrúbosť	
22701	50	1
22702	100	1
22703	200	1
22704	400	1
22705	800	1
22706	1500	1
22707	3000	1

FESTA

UNÁŠAČ BRÚSNEHO PAPIERA SO SUCHÝM ZIPSOM

- M14 | Ø 8 mm
- EVA10 mm

M14

Č.p.	špecifikácia	
22062	Ø 115 mm	25
22063	Ø 125 mm	25
22064	Ø 150 mm	10

**FESTA**

UNÁŠAČ PRE FÍBROVÉ KOTUČE

NORTON MADE IN EU
SAINT-GOBAIN

M14

Č.p.	špecifikácia	
22073	Ø 125 mm, M14	1
22074	Ø 150 mm, M14	1

**FESTA**

UNÁŠAČ DIAMANTOVÝCH LEŠTIACICH KOTUČOV

- pre uhlovú brúsku

M14

Č.p.	špecifikácia	
22043	Ø 100 mm so suchým zipsom	1

UNÁŠAČ BRÚSNEHO PAPIERA

- pre uhlovú brúsku

M14

Č.p.	špecifikácia	
22044	Ø 125 mm M14 so suchým zipsom	15
22060	Ø 150 mm M14 so suchým zipsom	6

ADAPTÉR

M14

Č.p.	špecifikácia	
22087		1



UNÁŠAČ BRÚSNEHO PAPIERA KLBOVÝ

Č.p.	špecifikácia	stopka shank	
22061	Ø 125 mm so suchým zipsom	Ø 8 mm	6

UNÁŠAČ BRÚSNEHO PAPIERA

Č.p.	špecifikácia	
22041	Ø 125 mm upínanie skrutkou	11
22042	Ø 125 mm so suchým zipsom	11



KOTÚČ LEŠTIACI, BARÁNOK



Č.p.	špecifikácia	špecifikácia	
22065	Ø 125 mm	so suchým zipsom	20
22066	Ø 150 mm	so suchým zipsom	20



KOTÚČ LEŠTIACI, BARÁNOK S GOLIEROM



Č.p.	špecifikácia	
22068	Ø 125 mm	20
22069	Ø 150 mm	20

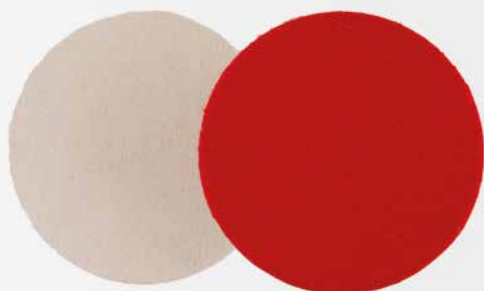

FILC LEŠTIACI SO SUCHÝM ZIPSOM



Č.p.	špecifikácia	
22070	Ø 115 mm	20
22071	Ø 125 mm	so suchým zipsom 20
22072	Ø 150 mm	20



Ø 6 mm

KOTÚČ NYLONOVÝ, BRÚSNY



Č.p.	špecifikácia	
22091	Ø 50 mm P240	1
22092	Ø 75 mm P240	1
22093	Ø 100 mm P240	1



KOTÚČ NYLON S PODLOŽKOU



Č.p.	špecifikácia	
21798	Ø 125 mm Ø 22,2 mm	1



Ø 6 mm

KOTÚČ NYLONOVÝ, STOPKA



Č.p.	špecifikácia	
22088	Ø 65 mm	9
22090	Ø 100 mm	5



KOTÚČ NYLON S PODLOŽKOU



Č.p.	špecifikácia	
22083	Ø 115 mm Ø 22,2 mm	10
22084	Ø 125 mm Ø 22,2 mm	10
22085	Ø 150 mm Ø 22,2 mm	10



KOTÚČ NYLONOVÝ



Č.p.	špecifikácia	
22095	Ø 178 mm	1

**FESTA**

KOTÚČE FIBROVÉ - Ø 125 MM

3x



Č.p.	hrubosť	
22160	P40	1
22161	P60	1
22162	P80	1
22163	P100	1
22164	P120	1

**FESTA**

KOTÚČE FIBROVÉ - Ø 150 MM

3x



Č.p.	hrubosť	
22166	P60	1
22167	P80	1
22168	P100	1

**FESTA**

PAPIER BRÚSNY Ø 125 MM, SO SUCHÝM ZIPSOM

3x



Č.p.	hrubosť	
22045	P40	1
22046	P60	1
22047	P80	1
22048	P100	1
22049	P120	1
22050	P150	1
22051	P180	1
22052	P220	1

**FESTA**

PAPIER BRÚSNY Ø 150 MM, SO SUCHÝM ZIPSOM

3x

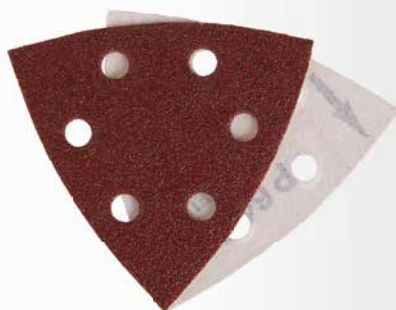

Č.p.	hrubosť	
22053	P40	1
22054	P60	1
22055	P80	1
22056	P100	1
22057	P120	1

**FESTA**VIBRAČNÝ VÝSEK
94 X 94 X 94 MM

5x



Č.p.	hrubosť	
21831	P60	1
21832	P80	1
21834	P120	1

PAPIER BRÚSNY SO SUCHÝM
ZIPSOM - 125 MM

3x

Č.p.	hrubosť	
22096	P40	20
22097	P60	20
22098	P80	20
22099	P120	20

**FESTA**NEKONEČNÝ BRÚSNY PÁS -
75 X 533 MM

3x



Č.p.	hrubosť	
21810	P40	20
21811	P60	20
21812	P80	20
21813	P100	20
21814	P120	20



PAPIER BRÚSNY 93 X 230 MM

5x



Č.p.	hrubosť	počet otvorov	
21740	P40	8	20
21741	P60	8	20
21742	P80	8	20
21743	P100	8	20
21744	P120	8	20



PAPIER BRÚSNY 115 X 280 MM

5x



Č.p.	hrubosť	počet otvorov	
21750	P40	10	20
21751	P60	10	20
21752	P80	10	20
21753	P100	10	20
21754	P120	10	20



PLÁTNO BRÚSNE 230 X 280 MM

10x

Č.p.	hrubosť	
21732	P40	1
21734	P60	1
21735	P80	1
21736	P100	1
21737	P120	1

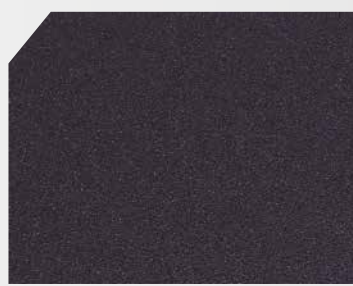

PAPIER BRÚSNY VODEODOLNÝ 230 X 280 MM

10x

Č.p.	hrubosť	
21701	P60	1
21702	P80	1
21703	P100	1
21704	P120	1
21705	P150	1
21706	P180	1
21709	P240	1



PAPIER BRÚSNY 230 X 280 MM

10x

Č.p.	hrubosť	
21715	P40	1
21716	P60	1
21717	P80	1
21718	P100	1
21719	P120	1
21720	P150	1
21721	P180	1
21724	P240	1



FESTA

DRŽIAK BRÚSNEHO PAPIERA

· rýchlopínací

Č.p.	špecifikácia	
22067	170 x 70 mm	10



DRŽIAK BRÚSNEHO PAPIERA



Č.p.	špecifikácia	
22075	210 x 105 mm	100
22076	160 x 85 mm	100



DRŽIAK BRÚSNEHO PAPIERA 125 X 68 MM

Č.p.	špecifikácia	
22077	125 x 68 mm	10

**FESTA****HUBA DIAMANTOVÁ BRÚSNA**

· 90 x 55 x 25 mm

- keramické obklady
- sklo
- mramor
- žula



Č.p.	hrúbosť	
22115	P60	10
22116	P120	10
22117	P200	10

BRÚSNY LAMELOVÝ KOTUČ NA STOPKE

Č.p.	hrúbosť	špecifikácia	
21850	P40		1
21851	P60		1
21852	P80	20 x 20, Ø 6 mm	1
21853	P100		1
21854	P120		1
21855	P40		1
21856	P60		1
21857	P80	30x30, Ø 6mm	1
21858	P100		1
21859	P120		1
21860	P40		1
21861	P60		1
21862	P80	60x30, Ø 6mm	1
21863	P100		1
21864	P120		1

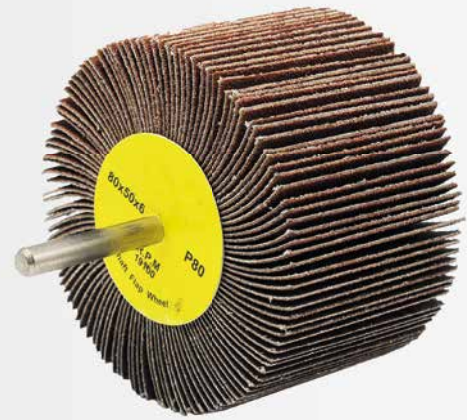
**FESTA****HUBA BRÚSNA 100 X 70 X 28 MM - SKOSENÁ**

Č.p.	hrúbosť	
22106	P 60	10
22107	P 80	10
22108	P 100	10
22109	P 120	10

**FESTA****HUBA BRÚSNA 100 X 70 X 25 MM**

Č.p.	hrúbosť	
22100	P60	20
22101	P80	20
22102	P100	20
22103	P120	20
22104	P180	20
22105	P220	20

**FESTA****HUBA BRÚSNA 120 X 95 X 10 MM**

Č.p.	hrúbosť	
22110	P80	20
22111	P120	20
22112	P180	20
22113	P220	20





NÁRADIE NA SADROKARTÓN



RAŠPĽA NA SADROKARTÓN

Č.p.	špecifikácia	
22120	250 x 40 mm	10



RAŠPĽA NA SADROKARTÓN

Č.p.	špecifikácia	
22121	250 x 40 mm	10
22122	140 x 40 mm	6



RAŠPĽA NA SADROKARTÓN

Č.p.	špecifikácia	
22126	155 x 40 mm	1



RAŠPĽA NA SADROKARTÓN

Č.p.	špecifikácia	
22125	Ø 250 x 40 mm	6



RAŠPĽA NA SADROKARTÓN

Č.p.	špecifikácia	
22124	Ø 250 x 16 mm	10



RAŠPĽA NA SADROKARTÓN

Č.p.	špecifikácia	
22123	60 x 40 mm	6



FESTA
PÍLKA NA SADROKARTÓN

Č.p.	špecifikácia	
24159	150 mm	12

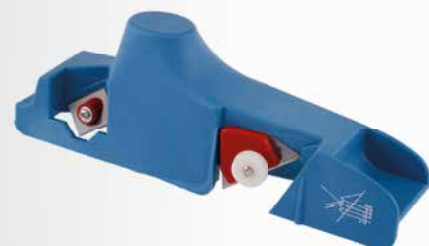

HOBLÍK NA SADROKARTÓN

Č.p.	špecifikácia	
34315		10
34316	náhradný břit	1



PÍLKA VRTACIA NA SADROKARTÓN

Č.p.	špecifikácia	
24190	270 mm	10

RAŠPĽA NÁHRADNÁ

Č.p.	špecifikácia	
22130	250 x 40 mm	20
22129	155 x 40 mm	20
22132	140 x 40 mm	20
22133	60 x 40 mm	20
22134	Ø 16 x 250 mm	20





RAŠPLE A PILNÍKY



FESTA PILNÍK PLOCHÝ



Č.p.	špecifikácia	hrúbosť	
22206	150 mm	2	10
22180	250 mm	2	10



FESTA PILNÍK ŠTVORHRANNÝ



Č.p.	špecifikácia	hrúbosť	
22184	250 mm	2	10



FESTA PILNÍK TROJHRANNÝ



Č.p.	špecifikácia	hrúbosť	
22183	250 mm	2	10



FESTA PILNÍK POLOGULATÝ



Č.p.	špecifikácia	hrúbosť	
22207	150 mm	2	10
22182	250 mm	2	10



FESTA PILNÍK TROJHRANNÝ NA PÍLOVÉ ZUBY



Č.p.	špecifikácia	hrúbosť	
22178	150 mm	1	10



FESTA PILNÍK GULATÝ



Č.p.	špecifikácia	hrúbosť	
22181	250 mm	2	10



FESTA PILNÍKY - SADA



5x



Č.p.	špecifikácia	hrúbosť	
22209	150 mm	2	10
22186	250 mm	2	5



FESTA PILNÍKY - SADA



3x



Č.p.	špecifikácia	hrúbosť	
22208	150 mm	2	10
22185	250 mm	2	5



FESTA

RAŠPĽA PLOCHÁ



Č.p.	špecifikácia	
22202	150 mm	10
22197	300 mm	10



FESTA

RAŠPĽA GULATÁ



Č.p.	špecifikácia	
22204	150 mm	10
22205	250 mm	10
22198	300 mm	10

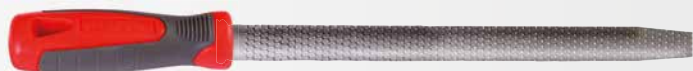

FESTA

RAŠPĽA POLOGULATÁ



Č.p.	špecifikácia	
22203	150 mm	6
22199	300 mm	6

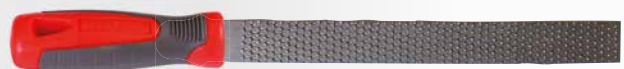

FESTA

RAŠPĽA - SADA



3x



Č.p.	špecifikácia	
22195	300 mm	5



FESTA

PILNÍK NA REŤAZOVÚ PÍLU



Č.p.	špecifikácia		Č.p.	špecifikácia	
22170	200 mm 3,5 mm	10	22173	200 mm 5 mm	10
22171	200 mm 4 mm	10	22174	200 mm 5,5 mm	10
22172	200 mm 4,5 mm	10			



FESTA

PILNÍKY IHLOVÉ - SADA

10x



Č.p.	špecifikácia	
22188		20



FESTA

SADA NA BRÚSENIE REŤAZÍ



Č.p.	špecifikácia	
22190	300 mm	5



FESTA

PILNÍKY DIAMANTOVÉ - SADA

10x



Č.p.	špecifikácia	
22189		25

FESTA®

Č.p.	špecifikácia	počet zubov	
Ø 115 mm			
22300	Ø 115 x 22 mm	40	1
Ø 125 mm			
22301	Ø 125 x 22 mm	40	1
Ø 140 mm			
22302	Ø 140 x 20 mm	24	1
22303	Ø 140 x 20 mm	30	1
Ø 150 mm			
22305	Ø 150 x 20 mm	24	1
Ø 160 mm			
22307	Ø 160 x 20 mm	18	1
22309	Ø 160 x 20 mm	24	1
22310	Ø 160 x 20 mm	30	1
22311	Ø 160 x 20 mm	36	1
22312	Ø 160 x 20 mm	48	1
22313	Ø 160 x 20 mm	60	1
Ø 165 mm			
22314	Ø 165 x 20 mm	24	1
Ø 180 mm			
22315	Ø 180 x 30 mm	24	1
22317	Ø 180 x 30 mm	50	1
22318	Ø 180 x 20 mm	50	1
Ø 190 mm			
22319	Ø 190 x 20 mm	40	1
22320	Ø 190 x 30 mm	40	1
Ø 200 mm			
22322	Ø 200 x 30 mm	24	1
22324	Ø 200 x 30 mm	40	1
22326	Ø 200 x 30 mm	60	1
Ø 205 mm			
22328	Ø 205 x 30 mm	40	1
22329	Ø 205 x 30 mm	60	1
Ø 210 mm			
22332	Ø 210 x 30 mm	40	1
22333	Ø 210 x 30 mm	60	1
Ø 250 mm			
22335	Ø 250 x 30 mm	40	1
22337	Ø 250 x 30 mm	60	1
Ø 300 mm			
22340	Ø 300 x 30 mm	40	1
22343	Ø 300 x 30 mm	60	1
22345	Ø 300 x 30 mm	96	1
Ø 350 mm			
22350	Ø 350 x 30 mm	40	1
22351	Ø 350 x 30 mm	54	1
Ø 400 mm			
22355	Ø 400 x 30 mm	40	1
22357	Ø 400 x 30 mm	60	1
Ø 500 mm			
22365	Ø 500 x 30 mm	60	1
Ø 600 mm			
22370	Ø 600 x 30 mm	60	1

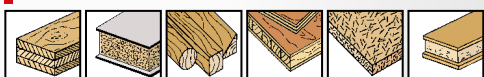
FESTA
KOTUČ PÍLOVÝ DO DREVA S SK PLÁTKAMI

REDUKČNÝ KRÚŽOK

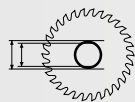
Č.p.	špecifikácia	
22399	Ø 20 16 mm	1
22398	Ø 30 25 mm	1













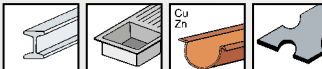

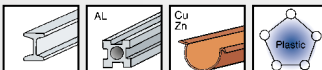

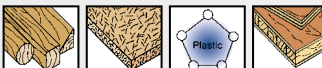
PROFESIONÁLNE PRIAMOČIARE PÍLKY
VYROBENÉ V NEMECKU TECHNOLOGIOU VYPALOVANÍM LASEROM

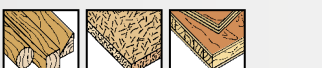

PÍLKA PRIAMOČIARA HSS - UCHYTENIE AEG, BOSCH, FESTO, MAKITA, METABO

	24060	50mm/1mm	0,7 mm/ 36TPI	31007	5 ks	10		
	24061	50mm/1mm	1,2 mm/ 21TPI	31012	5 ks	10		
	24062	50mm/1mm	2,0 mm/ 13TPI	31020	5 ks	10		
	24063	75mm/1mm	3,0 mm/ 8TPI	31030	5 ks	10		
	24064	100mm/1mm	1,2 mm/ 21TPI	31112	5 ks	10		
	24065	100mm/1,3mm	2,0 mm/ 13TPI	31112	5 ks	10		
	24066	75mm/1,45mm	2,0 mm/ 13TPI	31220	5 ks	10		
	24067	120mm/1,3mm	1,8 - 2,4 mm/ 10 - 14 TPI	31220	5 ks	10		
	24068	75mm/1,45mm	2,5 mm/ 10 TPI	32225	5 ks	10		
	24069	75mm/1,45mm	4 mm/ 6 TPI	32240	5 ks	10		
	24070	75mm/1,3mm	4 mm/ 6 TPI	32340	5 ks	10		
	24071	75mm/1,3mm	4 mm/ 6 TPI	32440	5 ks	10		
	24072	75mm/1,45mm	2,5 mm/ 10 TPI	32625	5 ks	10		
	24073	85mm/1,45mm	3 mm/ 8 TPI	32730	5 ks	10		
	24074	85mm/1,45mm	4 mm/ 6 TPI	32730	5 ks	10		
	32825	75mm/1,45mm	2,5 1,2 mm/10 21 TPI	32825	5 ks	10		
	24076	75mm/1,7mm	4 mm 6 TPI	32940	5 ks	10		
	24077	120mm/1,3mm	4 mm 6 TPI	32040	5 ks	10		
	24078	105mm/1,45mm	4 mm 6 TPI	34040	5 ks	10		
	24055	55mm	karbidová		5 ks	1		

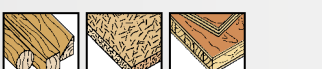
PÍLKA PRIAMOČIARA HSS - UCHYTENIE BLACK & DECKER, FERM

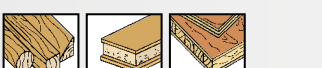
	24080	50mm 1,0 mm	1,2 21 TPI	11012	5 ks	10	
	24081	75mm 1,0 mm	3,0 8 TPI	11030	5 ks	10	
	24082	75mm 1,45 mm	2,5 10 TPI	12225	5 ks	10	
	24083	75mm 1,45 mm	4 6 TPI	12240	5 ks	10	
	24084	75mm 1,3 mm	4 6 TPI	12340	5 ks	10	
	24085	50mm 1,0 mm	2,0 13 TPI	12420	5 ks	10	
	24086	75mm 1,3 mm	4,0 6 TP	12440	5 ks	10	
	24087	75mm 1,45 mm	2,5 10 TPI	12625	5 ks	10	

	mäkká oceľ (S malým obsahom uhlíka)		oceľový plech		nehrdzavejúca oceľ		laminované dosky
	neželezné kovy		tvrdé a mäkké drevo		drevotrieska		plasty
	preglejka		latová preglejka		drevo s klinkami		
	sendvičový materiál		dlažba a obklady		hliník		

STOJAN PRIAMOČIARYCH PÍLOK

- osadenie stojana 24098 - 24060 · 5 ks
- 24080 · 5 ks
- 24061 · 5 ks
- 24062 · 5 ks
- 24081 · 5 ks
- 24063 · 5 ks
- 24066 · 5 ks
- 24067 · 5 ks
- 24082 · 5 ks
- 24068 · 5 ks
- 24083 · 5 ks
- 24069 · 5 ks
- 24084 · 5 ks
- 24070 · 5 ks
- 24086 · 5 ks
- 24071 · 5 ks
- 24087 · 5 ks
- 24072 · 5 ks
- 24073 · 5 ks
- 24074 · 5 ks
- 24075 · 5 ks
- 24076 · 5 ks



SADA PRIAMOČIARYCH PÍLOK



5x

Č.p.	špecifikácia	
24045	sada	50

Č.p.	špecifikácia	
24099	64 x 50 cm - prázdny	1
24098	64 x 50 cm - osadený	1

FESTA

PÍLOVÝ PLÁTOK

HCS 3x

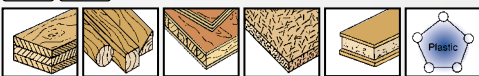

Č.p.	špecifikácia		
24301	150 x 19 x 1,3 mm	TPI 6	1

FESTA

PÍLOVÝ PLÁTOK

HCS 3x

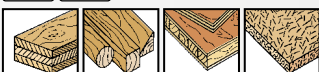

Č.p.	špecifikácia		
24302	225 x 19 x 1,3 mm	TPI 3	1

FESTA

PÍLOVÝ PLÁTOK

HCS 3x

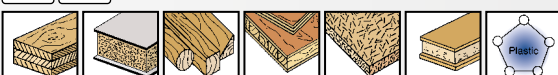

Č.p.	špecifikácia		
24303	200 x 19 x 1,3 mm	TPI 6 - 10	1

FESTA

PÍLOVÝ PLÁTOK

HCS 3x

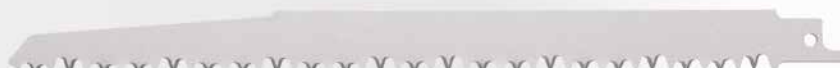

Č.p.	špecifikácia		
24304	240 x 19 x 1,5 mm	TPI 5	1

FESTA

PÍLOVÝ PLÁTOK

Bi Metal 3x

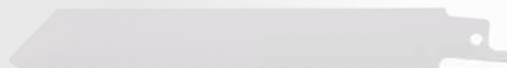
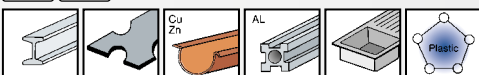

Č.p.	špecifikácia		
24305	150 x 19 x 1 mm	TPI 24	1

FESTA

PÍLOVÝ PLÁTOK

Bi Metal 3x

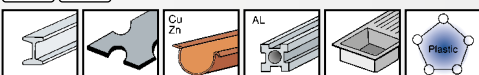

Č.p.	špecifikácia		
24306	150 x 19 x 1 mm	TPI 9	1

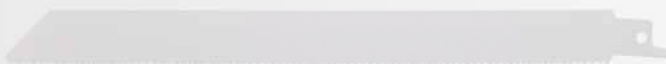
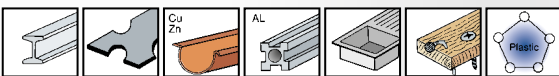
FESTA**PÍLOVÝ PLÁTOK****Bi**
Metal **3x**

Č.p. 24308 špecifikácia 225 x 19 x 1 mm TPI 10 - 14

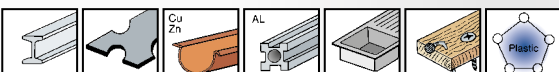

1

FESTA**PÍLOVÝ PLÁTOK****Bi**
Metal **3x**

Č.p. 24310 špecifikácia 150 x 22 x 1,6 mm TPI 9

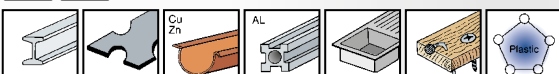

1

FESTA**PÍLOVÝ PLÁTOK****Bi**
Metal **3x**

Č.p. 24313 špecifikácia 225 x 22 x 1,6 mm TPI 6

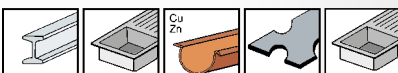

1

FESTA**PÍLA NA KOV HSS****HSS**

Č.p. 24050 špecifikácia 203 x 19 x 1 mm TPI 10 - 14



25

FESTA**PÍLOVÝ PLÁTOK**

· SK zuby, dlhá životnosť

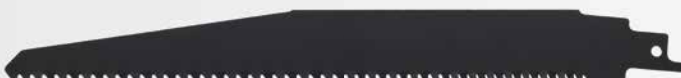
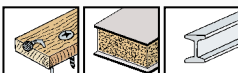
TC **3x**

Č.p. 24312 špecifikácia 225 x 19 x 1,3 mm TPI 6 - 9



1

FESTA**PÍLOVÝ PLÁTOK****TC**

Č.p. 24315 špecifikácia 305 x 50 x 1,5 mm
24316 455 x 50 x 1,5 mm



1

25

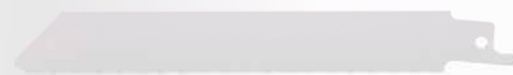
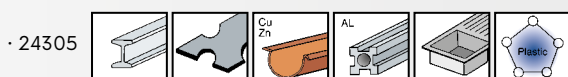

FESTA

SADA PILOVÝCH PLÁTKOV

Bi Metal HCS 3x



Č.p. špecifikácia

24314



1



PILOVÝ PLÁTOK

· kalené zuby



Č.p.	špecifikácia	
24185	533 mm	1
24186	610 mm	1
24187	760 mm	1
24188	800 mm	1
24189	914 mm	1

FESTA

PILOVÝ PLÁTOK

· kalené zuby



Č.p.	špecifikácia	
24169	350 mm	10
24167	450 mm	10
24166	533 mm	10
24163	610 mm	10
24164	760 mm	10
24168	800 mm	10
24165	914 mm	10



PILOVÝ PLÁTOK



Č.p.	špecifikácia	
24195	rozteč 3 mm 300 mm	1
24196	rozteč 4 mm 300 mm šikmý zub	1
24197	rozteč 5 mm 300 mm kalený zub	1
24192	pilový list do reznické pily 450 mm	1

PILOVÝ PLÁTOK

Č.p.	špecifikácia	
24160	rozteč 3 mm 300 mm	20
24161	rozteč 4 mm 300 mm	20
24162	rozteč 5 mm 300 mm	50

PILOVÝ PLÁTOK

10x



Č.p. špecifikácia

24108

6 mm | 150 mm

1

REZACIA STRUNA



Č.p. špecifikácia

24120

300 mm



50

**FESTA****PÍLOVÝ PLÁTKO BI - METAL**

· 8 % COBALT



Č.p.	špecifikácia
24180	300 mm

125

FESTA**PÍLOVÝ PLÁTKO**

MOQ

Č.p.	špecifikácia		
24109	12,5 mm 300 mm	na kov	144
24118	25 mm 300 mm	na kov oboustranná	72
24119	25 mm 300 mm	na kov a dřevo	72

FESTA**PÍLA NA KOV**

Č.p.	špecifikácia
24104	300 mm

6

**FESTA****PÍLA NA KOV**

· zesílený rám



Č.p.	špecifikácia
24102	300 mm

6

**PÍLA NA KOV**

Č.p.	špecifikácia
24153	300 mm

12

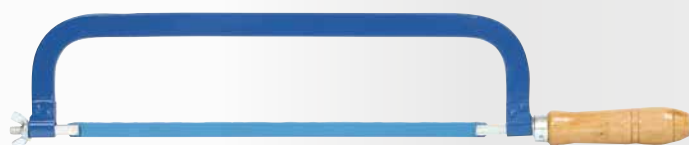
**PÍLA NA KOV**

Č.p.	špecifikácia
24100	300 mm

12

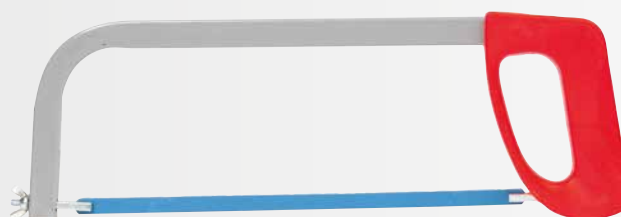



PÍLA NA KOV



Č.p.	špecifikácia	
24170	300 mm	12



FESTA
PÍLA NA KOV



2x



Č.p.	špecifikácia	
24126	300 x 25 x 0,65 mm TPI 24 14	10



PÍLA NA KOV

· plátky 24108



Č.p.	špecifikácia	
24125	150 mm	6



PÍLA NA KOV

· plátky 24109



Č.p.	špecifikácia	
24124	260 mm	12

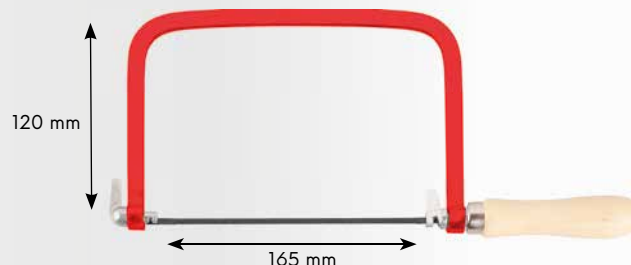

PÍLA



Č.p.	špecifikácia	
24121	píla	12
24110	pílový plátok	30

PÍLA

· 5x plátky



Č.p.	špecifikácia	
24122	píla	20
24111	pílový plátok	30

FESTA**PÍLA CHVOSTOVKA**

TEFLON



 · 3 x brúsené a kalené zuby



Č.p.	špecifikácia	
24143	300 mm	12
24144	400 mm	12
24145	500 mm	12

**FESTA****PÍLA ČAPOVKA**

TEFLON



 · 3 x brúsené a kalené zuby

Č.p.	špecifikácia	
24147	300 mm	6

FESTA**PÍLA DIEROVKA**

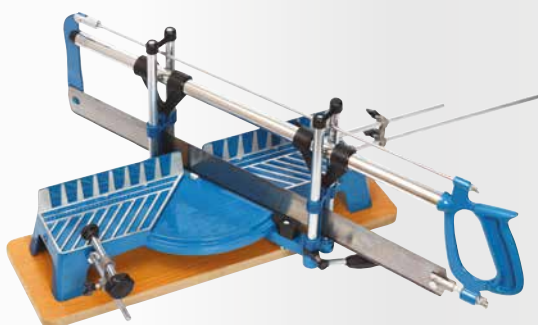
 · 3 x brúsené a kalené zuby



Č.p.	špecifikácia	
24149	300 mm	12

**PÍLA POKOSOVÁ PROFI**

Č.p.	špecifikácia	
24130	600 mm	1
24131	600 mm, pilový plátok	1

POKOSNICA PLASTOVÁ

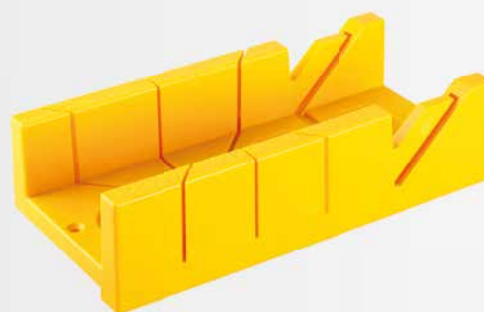
Č.p.	špecifikácia	
24133	300 x 140 mm	1

**POKOSNICA DŘEVĚNÁ**
 · buk
MADE IN EU

Č.p.	špecifikácia	
24171	80 x 300 mm	10

KOSOREZ + PÍLA

Č.p.	špecifikácia	
24148	300 mm	12





FESTA

PÍLA OBLÚKOVÁ

· kalené zuby

Č.p.	špecifikácia		Č.p.	špecifikácia	
24141	450 mm	12	24136	760 mm	12
24140	533 mm	12	24142	800 mm	12
24135	610 mm	12	24137	914 mm	12



FESTA

PÍLA OBLÚKOVÁ OTOČNÁ

· kalené zuby

Č.p.	špecifikácia	
24173	350 mm	24

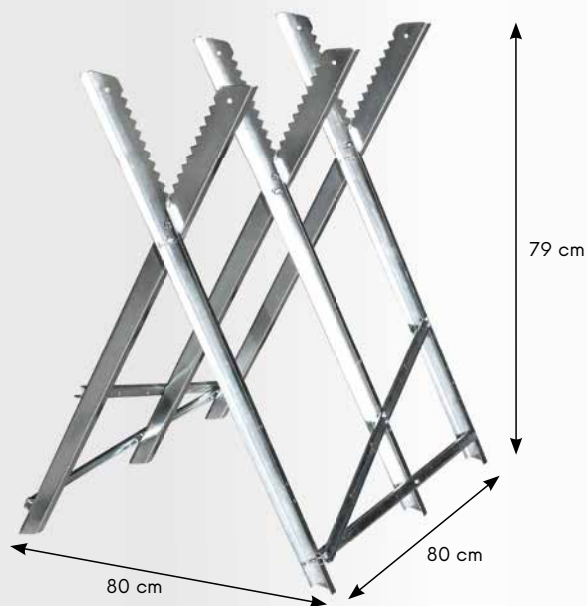

STOJAN NA REZANIE DREVA



Č.p.	špecifikácia	
37570	max. 150 kg	3



PÍLA ZAHRADNÁ



Č.p.	špecifikácia	
24151	300 mm	10

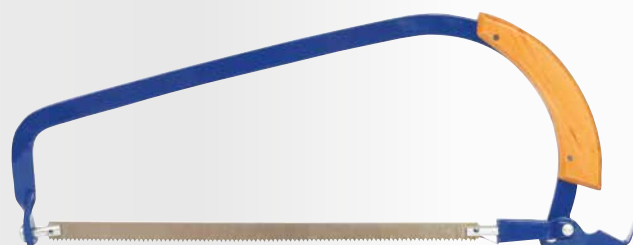

PÍLA ZAHRADNÁ - OTOČNÁ



Č.p.	špecifikácia	
24150	300 mm	5

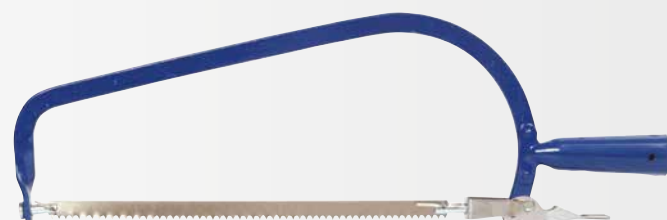

PÍLA ZAHRADNÁ - TULEJ



Č.p.	špecifikácia	
24154	300 mm	10



PÍLA

Č.p.	špecifikácia	
24128	450 mm plátky 24192	6

**FESTA****PÍLA ZATVÁRACIA**

· 3 x brúsené a kalené zuby

Č.p.	špecifikácia
45061	150 mm s krytem rukojeti



12

**FESTA****PÍLA ZATVÁRACIA**

· 3 x brúsené a kalené zuby

Č.p.	špecifikácia
45060	180 mm



6

**FESTA****PÍLA S PUZDROM**

· 3 x brúsené a kalené zuby

Č.p.	špecifikácia
45062	260 mm s pouzdom



24

**FESTA****PÍLA PROREZÁVACIA**

· 3 x brúsené a kalené zuby

Č.p.	špecifikácia
24152	350 mm 7 tpi



12

**FESTA****PÍLA TELESKOPICKÁ PROREZÁVACIA**

· 3 x brúsené a kalené zuby

Č.p.	špecifikácia
45033	230 - 490 mm



1

**HÚSENICA S PÍLOU**

Č.p.	špecifikácia
45030	pílka 30 cm teleskopická tyč 260 cm
45031	pílka 30 cm



6

**HÚSENICA**

Č.p.	špecifikácia
45032	kovová húsenica bez píly



6



FESTA
PÍLA NA POLYSTYREN

Č.p.	špecifikácia	
24174	370 mm	1



FESTA
PÍLA NA SADROKARTÓN



3 x brúsené a kalené zuby



Č.p.	špecifikácia	
24159	150 mm	12



PÍLA VRTACIA NA SADROKARTÓN



Č.p.	špecifikácia	
24190	270 mm	10



FESTA
PÍLA NA DUTÉ TEHLY (PORO-THERM)



Č.p.	špecifikácia	
24181	550 mm	1



FESTA
PÍLA NA PÓROBETÓN



Č.p.	špecifikácia	
24158	22 22 SK zubů - 450 mm	5



FESTA
PÍLA NA PÓROBETÓN



Č.p.	špecifikácia	
24155	34 17 SK zubů - 630 mm	2
24156	34 34 SK zubů - 630 mm	2



FESTA
PÍLA NA PÓROBETÓN

Č.p.	špecifikácia	
24176	34 17 SK zubů - 750 mm	6
24177	34 34 SK zubů - 750 mm	6



FESTA
PÍLA NA PÓROBETÓN

· kalené zuby







Č.p.	špecifikácia	
24175	bez SK zubů - 600 mm EU	2
24178	bez SK zubů - 600 mm	6

FESTA®



Použitie rezných diamantových kotoučov

				
	festa industry	plný	turbo	segment
materiály				
cihla	••	••	••	••
obklady	••	•••	••	-
zdivo, kámen	••	••	••	••
beton	•••	•	•••	•••
železobetón	••••	-	•••	-
střešní tašky	••	•	••	••
sklo a keramika	-	•••	-	-
mramor	•	••	•	•
žula	•••	••	•••	••
pískovec	••	-	••	••
asfalt	-	••	-	••
křemen	••	•	••	•



FESTA
INDUSTRY

KOTUČ DIAMANTOVÝ

Č. p.	špecifikácia			
21200	Ø 115 mm 1,4 mm	Ø 22,2 mm	1	
21201	Ø 125 mm 1,4 mm	Ø 22,2 mm	1	
21204	Ø 200 mm 1,8 mm	Ø 25,4 mm	1	
21203	Ø 230 mm 1,8 mm	Ø 22,2 mm	1	

FESTA

KOTUČ DIAMANTOVÝ PLNÝ

Č. p.	špecifikácia			
21210	Ø 110 mm Ø 22,2 mm	1		
21211	Ø 115 mm Ø 22,2 mm	1		
21212	Ø 125 mm Ø 22,2 mm	1		
21215	Ø 150 mm Ø 22,2 mm	1		
21218	Ø 180 mm Ø 22,2 mm	1		
21219	Ø 180 mm Ø 25,4 mm	1		
21220	Ø 200 mm Ø 25,4 mm	1		
21223	Ø 230 mm Ø 22,2 mm	1		
21224	Ø 300 mm Ø 25,4 mm	1		



FESTA

KOTUČ DIAMANTOVÝ SEGMENTOVÝ

Č.p.	špecifikácia		
21311	Ø 115 mm	Ø 22,2 mm	1
21312	Ø 125 mm	Ø 22,2 mm	1
21315	Ø 150 mm	Ø 22,2 mm	1
21318	Ø 180 mm	Ø 22,2 mm	1
21323	Ø 230 mm	Ø 22,2 mm	1
21324	Ø 300 mm	Ø 25,4 mm	1
21327	Ø 350 mm	Ø 25,4 mm	1
21326	Ø 400 mm	Ø 25,4 mm	1



FESTA

KOTUČ DIAMANTOVÝ TURBO

Č.p.	špecifikácia		
21410	Ø 110 mm	Ø 22,2 mm	1
21411	Ø 115 mm	Ø 22,2 mm	1
21412	Ø 125 mm	Ø 22,2 mm	1
21415	Ø 150 mm	Ø 22,2 mm	1
21418	Ø 180 mm	Ø 22,2 mm	1
21423	Ø 230 mm	Ø 22,2 mm	1
21424	Ø 300 mm	Ø 25,4 mm	1



FESTA

KOTUČ REZNÝ DIAMANTOVÝ UNIVERZÁLNY



Č.p.	špecifikácia			
21301	Ø 125 mm	Ø 22,2 mm	1,5 mm	1
21303	Ø 230 mm	Ø 22,2 mm	1,8 mm	1

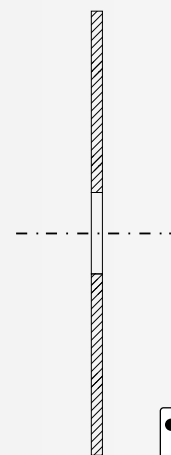

KOTÚČ DIAMANTOVÝ PLNÝ

Č. p.	špecifikácia		
21010	Ø 110 mm	Ø 22,2 mm	1
21011	Ø 115 mm	Ø 22,2 mm	1
21012	Ø 125 mm	Ø 22,2 mm	1
21015	Ø 150 mm	Ø 22,2 mm	1
21018	Ø 180 mm	Ø 22,2 mm	1
21023	Ø 230 mm	Ø 22,2 mm	1



KOTÚČ DIAMANTOVÝ SEGMENTOVÝ

Č. p.	špecifikácia		
21110	Ø 110 mm	Ø 22,2 mm	1
21111	Ø 115 mm	Ø 22,2 mm	1
21112	Ø 125 mm	Ø 22,2 mm	1
21115	Ø 150 mm	Ø 22,2 mm	1
21118	Ø 180 mm	Ø 22,2 mm	1
21123	Ø 230 mm	Ø 22,2 mm	1



KOTÚČ DIAMANTOVÝ TURBO

Č. p.	špecifikácia		
21130	Ø 110 mm	Ø 22,2 mm	1
21135	Ø 115 mm	Ø 22,2 mm	1
21140	Ø 125 mm	Ø 22,2 mm	1
21150	Ø 150 mm	Ø 22,2 mm	1
21180	Ø 180 mm	Ø 22,2 mm	1
21190	Ø 230 mm	Ø 22,2 mm	1



FESTA

KOTÚČ DIAMANTOVÝ BRUSNÝ DVOJRADOVÝ



Č.p.	špecifikácia		
21430	Ø 115 mm	Ø 22,2 mm	1
21431	Ø 125 mm	Ø 22,2 mm	1
21432	Ø 150 mm	Ø 22,2 mm	1



FESTA

KOTÚČ DIAMANTOVÝ BRUSNÝ TURBO



Č.p.	špecifikácia		
21425	Ø 100 mm	Ø 22,2 mm	1
21426	Ø 115 mm	Ø 22,2 mm	1
21427	Ø 125 mm	Ø 22,2 mm	1
21428	Ø 150 mm	Ø 22,2 mm	1



6 mm



FESTA

KOTÚČ DIAMANTOVÝ SEGMENTOVÝ, DVOJITÝ



Č.p.	špecifikácia		
21195	Ø 125 x 22,2 mm		1

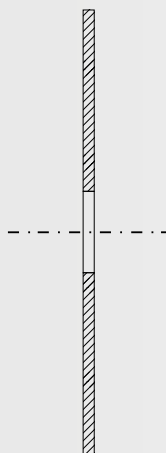

NEW



FESTA

KOTUČ REZNÝ NA KOV



INOX

Č.p.	špecifikácia			
22211	Ø 115 mm	Ø 22,2 mm x 1 mm	INOX	50
22212	Ø 115 mm	Ø 22,2 mm x 1,2 mm	INOX	50
22225	Ø 125 mm	Ø 22,2 mm x 1 mm	INOX	50
22217	Ø 125 mm	Ø 22,2 mm x 1,2 mm	INOX	50

Č.p.	špecifikácia			
22251	Ø 115 mm	Ø 22,2 mm x 1,6 mm		50
22215	Ø 115 mm	Ø 22,2 mm x 2 mm		50
22216	Ø 115 mm	Ø 22,2 mm x 2,5 mm		50
22252	Ø 125 mm	Ø 22,2 mm x 1,6 mm		25
22218	Ø 125 mm	Ø 22,2 mm x 2,5 mm		25
22219	Ø 150 mm	Ø 22,2 mm x 1,2 mm		25
22253	Ø 150 mm	Ø 22,2 mm x 1,6 mm		50
22220	Ø 150 mm	Ø 22,2 mm x 2,5 mm		50
22254	Ø 180 mm	Ø 22,2 mm x 1,6 mm		50
22222	Ø 180 mm	Ø 22,2 mm x 2,5 mm		25
22255	Ø 230 mm	Ø 22,2 mm x 1,6 mm		25
22224	Ø 230 mm	Ø 22,2 mm x 2,5 mm		25

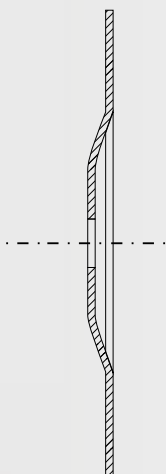

FESTA

KOTUČ BRUSNÝ NA KOV



Č.p.	špecifikácia			
22240	Ø 115 mm	Ø 22,2 mm x 6,4 mm		25
22242	Ø 125 mm	Ø 22,2 mm x 6,4 mm		25
22244	Ø 150 mm	Ø 22,2 mm x 6,4 mm		25
22246	Ø 180 mm	Ø 22,2 mm x 6,4 mm		25
22248	Ø 230 mm	Ø 22,2 mm x 6,4 mm		25

FESTA

KOTUČ REZNÝ NA KOV

10x



INOX

Č.p.	špecifikácia			
22228	Ø 115 mm	Ø 22,2 mm x 1 mm		1
22229	Ø 125 mm	Ø 22,2 mm x 1,2 mm		1

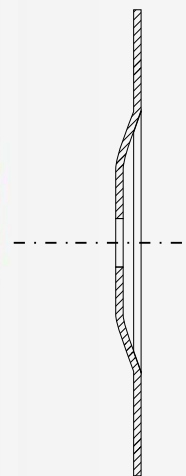
FESTA
INDUSTRY

KOTUČ REZNÝ NA KOV



INOX

MADE IN EU oSA

Č.p.	špecifikácia			
22258	NEW	Ø 115 mm	Ø 22,2 mm x 0,8 mm	25
22260		Ø 115 mm	Ø 22,2 mm x 1 mm	25
22263		Ø 115 mm	Ø 22,2 mm x 1,6 mm	25
22264	NEW	Ø 115 mm	Ø 22,2 mm x 2 mm	25
22259		Ø 125 mm	Ø 22,2 mm x 0,8 mm	25
22266		Ø 125 mm	Ø 22,2 mm x 1 mm	25
22269		Ø 125 mm	Ø 22,2 mm x 1,6 mm	25
22270		Ø 125 mm	Ø 22,2 mm x 2 mm	25
22273		Ø 150 mm	Ø 22,2 mm x 1,6 mm	25
22274		Ø 150 mm	Ø 22,2 mm x 2 mm	25
22275		Ø 150 mm	Ø 22,2 mm x 2,5 mm	25
22277		Ø 180 mm	Ø 22,2 mm x 2 mm	25
22280		Ø 230 mm	Ø 22,2 mm x 2 mm	25
22281		Ø 230 mm	Ø 22,2 mm x 2,5 mm	25

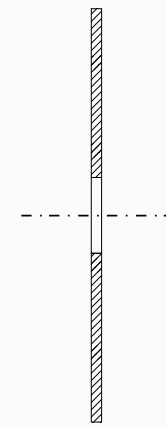
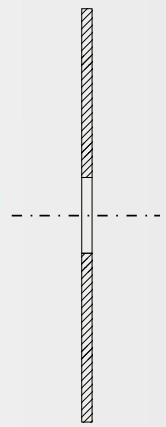

FESTA
INDUSTRY

KOTUČ REZNÝ NA HLINÍK



Č.p.	špecifikácia		
22285	Ø 115 mm	Ø 22,2 mm x 1 mm	1
22286	Ø 125 mm	Ø 22,2 mm x 1 mm	1

FESTA

KOTUČ REZNÝ NA KOV - DIAMANTOVÝ



Č.p.	špecifikácia		
21306	Ø 125 mm	Ø 22,2 mm	1,3 mm
21308	Ø 230 mm	Ø 22,2 mm	1,8 mm

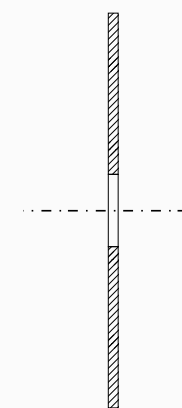

FESTA

KOTUČ REZNÝ UNIVERZÁLNY - KARBIDOVÝ



Č.p.	špecifikácia		
21192	Ø 125 mm	Ø 22,2 mm	1
21194	Ø 230 mm	Ø 22,2 mm	1

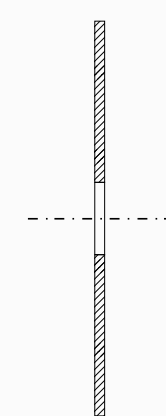
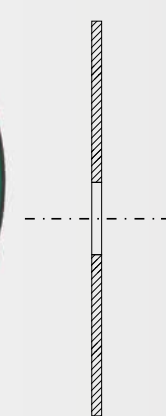

FESTA
INDUSTRY

KOTUČ REZNÝ NA KAMENĽ



Č.p.	špecifikácia		
22294	Ø 230 mm	Ø 22,2 mm x 3 mm	1

FESTA

KOTUČ REZNÝ NA KAMENĽ



Č.p.	špecifikácia		
22230	Ø 115 mm	Ø 22,2 mm x 2,5 mm	50
22232	Ø 125 mm	Ø 22,2 mm x 2,5 mm	50
22234	Ø 150 mm	Ø 22,2 mm x 2,5 mm	25
22236	Ø 180 mm	Ø 22,2 mm x 2,5 mm	25
22238	Ø 230 mm	Ø 22,2 mm x 2,5 mm	25

NEW

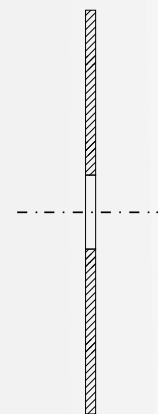

KOTUČ REZNÝ



Č. p.	Špecifikácia
21804	Ø 125 mm Ø 22,2 mm 14T

1

NEW

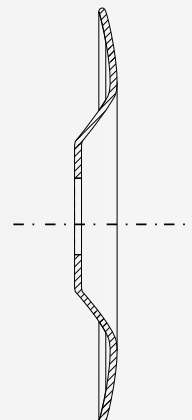
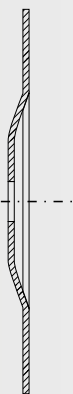

FESTA

PÍLOVÝ / RAŠPLOVÝ KOTUČ



Č. p.	Špecifikácia
21803	Ø 125 mm Ø 22,2 mm

1

FESTA

KOTUČ RAŠPLOVÝ - STŘEDNĚ HRUBÝ



Č. p.	Špecifikácia
21802	Ø 125 mm Ø 22,2 mm 3 mm

10

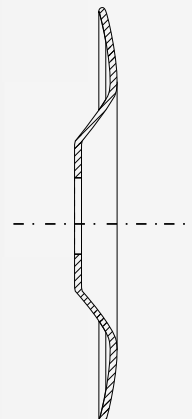

FESTA

KOTUČ RAŠPLOVÝ - HRUBÝ



Č. p.	Špecifikácia
21801	Ø 125 mm Ø 22,2 mm 3 mm

10

FESTA

KOTUČ NA DREVO S OTVORY

· brusný kotuč pre brúsenie dreva



Č. p.	Špecifikácia
21800	Ø 125 mm Ø 22,2 mm

1

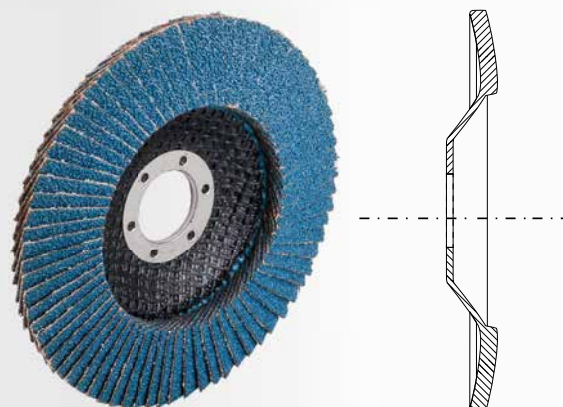
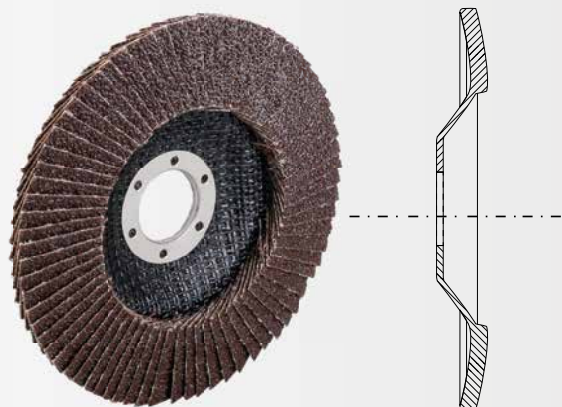

KOTÚČ LAMELOVÝ



Č.p.	špecifikácia	hrúbosť	
21780	Ø 115 mm Ø 22,2 mm	P40	10
21781	Ø 115 mm Ø 22,2 mm	P60	10
21782	Ø 115 mm Ø 22,2 m	P80	10
21783	Ø 115 mm Ø 22,2 mm	P100	10
21784	Ø 115 mm Ø 22,2 mm	P120	10
21786	Ø 125 mm Ø 22,2 mm	P40	10
21787	Ø 125 mm Ø 22,2 mm	P60	10
21788	Ø 125 mm Ø 22,2 mm	P80	10
21789	Ø 125 mm Ø 22,2 mm	P100	10
21790	Ø 125 mm Ø 22,2 mm	P120	10
21792	Ø 150 mm Ø 22,2 mm	P40	10
21793	Ø 150 mm Ø 22,2 mm	P60	10
21794	Ø 150 mm Ø 22,2 mm	P80	10
21795	Ø 150 mm Ø 22,2 mm	P100	10
21796	Ø 150 mm Ø 22,2 mm	P120	10

FESTA

KOTÚČ LAMELOVÝ

• brusný kotúč pre brúsenie nerezovej ocele



Č.p.	špecifikácia	hrúbosť	
22140	Ø 115 mm Ø 22,2 mm	P40	5
22141	Ø 115 mm Ø 22,2 mm	P60	5
22142	Ø 115 mm Ø 22,2 mm	P80	5
22143	Ø 115 mm Ø 22,2 mm	P100	5
22145	Ø 125 mm Ø 22,2 mm	P40	5
22146	Ø 125 mm Ø 22,2 mm	P60	5
22147	Ø 125 mm Ø 22,2 mm	P80	5
22148	Ø 125 mm Ø 22,2 mm	P100	5
22150	Ø 150 mm Ø 22,2 mm	P40	5
22151	Ø 150 mm Ø 22,2 mm	P60	5
22155	Ø 150 mm Ø 22,2 mm	P80	5
22156	Ø 150 mm Ø 22,2 mm	P100	5



KOTÚČ NYLON S PODLOŽKOU



Č.p.	špecifikácia	
21798	Ø 125 mm Ø 22,2 mm	1



MURÁRSKE HLADÍTKA,
LYŽICE, ŠPACHTLE

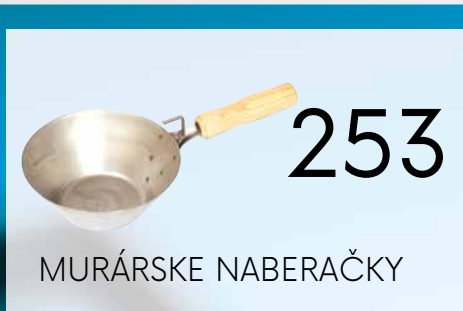

MURÁRSKE NABERAČKY



ŠKRABÁKY A BRÚSNA
HLADIDLA



HLADÍTKA A BRÚSNE
MRIEŽKY



HLADÍTKA PRE ÚPRAVU
OMIETOK



MIEŠADLA



PREDLŽOVACIE KÁBLE



ELEKTRICKÉ A PLYNOVÉ
OHRIEVAČE



STAVEBNÉ MIEŠAČKY



ZHADZOVANÍ STAVEBNEJ
SUTINY



STAVEBNÉ KOLIESKA



LAMAČE DLAŽBY A
NOSIČE OBRUBNÍKOV



REZAČKY DLAŽBY



POMÔCKY PRE
POKLADANIE DLAŽBY



NIVELÁCIA



REZAČKY NA POLYSTYRÉN

293



OMIETAČKY

298

PB HORÁKY A
REGULÁTORY TLAKU

300



MURÁRSKE NÁDOBY

304

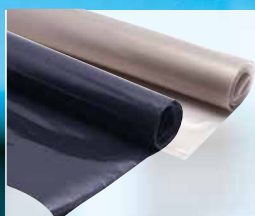

VRECIA NA SUŠ A ODPAD

305

LEPIACE A
MASKOVACIE PÁSKY

306



VYTLAČOVACIE PIŠTOĽE

310



PIŠTOĽE NA PU PENU

313

TEPLOVZDUŠNÉ A
TAVNÉ PIŠTOĽE

314

STAVEBNÉ NÁRADIE 242 - 329



MALIARSKÉ POTREBY

316



PE PLACHTY

322

KARABÍNY, REŤAZE A
OCEĽOVÉ LANÁ

324



STAVEBNÉ SVETLÁ

327



REBRÍKY

328

DVIERKA KOMÍNOVÉ A
DEBNIACE STOJKY

328

HLADIDLA, LYŽICE A ŠPACHTLE

FESTA
HLADIDLO NEREZ 280 X 130 MM

· gumová rukoväť



Č.p.	špecifikácia	
31140	rovné	10

10

FESTA
HLADIDLO NEREZ 280 X 130 MM

· gumová rukoväť



Č.p.	špecifikácia	
31148	rovné s oblými rohmi	10

10

FESTA
HLADIDLO NEREZ 280 X 130 MM ZUBOVÉ

· gumová rukoväť



Č.p.	špecifikácia	
31146	Ø 16	10

10

FESTA
HLADIDLO NEREZ 280 X 130 MM ZUBOVÉ

· gumová rukoväť



Č.p.	špecifikácia	
31141	e 4	10
31142	e 6	10
31143	e 8	10

Č.p.	špecifikácia	
31144	e 10	10
31145	e 12	10

FESTA
HLADIDLO NEREZ 280 X 130 MM ZUBOVÉ

Č.p.	špecifikácia	
31101	e 4	10
31111	e 6	10
31121	e 8	10

Č.p.	špecifikácia	
31131	e 10	10
31132	e 12	10

FESTA
HLADIDLO NEREZ 280 X 130 MM

Č.p.	špecifikácia	
31091	rovné	10

10



FESTA

HLADIDLO NEREZ 280 X 130 MM



Č.p.	špecifikácia	
31011	rovné	10



FESTA

HLADIDLO NEREZ 280 X 130 MM ZUBOVÉ



Č.p.	špecifikácia		Č.p.	špecifikácia	
31021	e 4	10	31051	e 10	10
31031	e 6	10	31053	e 12	10
31041	e 8	10			



HLADIDLO NEREZ 270 X 125 MM



Č.p.	špecifikácia	
31005	rovné	25



HLADIDLO NEREZ 270 X 125 MM ZUBOVÉ



Č.p.	špecifikácia		Č.p.	špecifikácia	
31006	e 4	24	31008	e 8	24
31007	e 6	24	31009	e 10	24



FESTA

HLADIDLO NEREZ 360 X 130 MM



Č.p.	špecifikácia	
31151	rovné	10

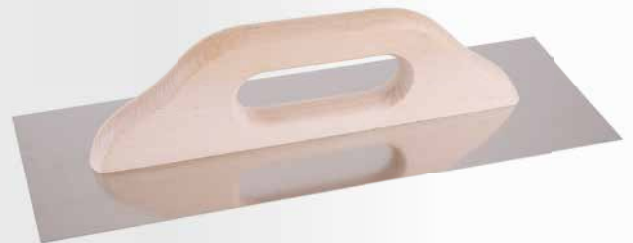

FESTA

HLADIDLO NEREZ 360 X 130 MM



Č.p.	špecifikácia	
31150	rovné	10



FESTA

HLADIDLO NEREZ 480 X 130 MM



Č.p.	špecifikácia	
31082	rovné	10



FESTA

HLADIDLO NEREZ 680 X 130 MM



Č.p.	špecifikácia	
31155	rovné	10

**FESTA**

HLADIDLO NEREZ 500 X 130 MM

INOX

Č.p.	špecifikácia	
31081	rovné	10

**FESTA**

HLADIDLO NEREZ 500 X 130 MM ZUBOVÉ

INOX

Č.p.	špecifikácia	
31052	e 4	10
31061	e 6	10
31062	e 8	10
31071	e 10	10
31072	e 12	10

**FESTA**

LYŽICA NEREZ

· gumová rukoväť

INOX

Č.p.	špecifikácia		Č.p.	rozméry	
31232	120 mm	10	31234	160 mm	10
31233	140 mm	10	31235	180 mm	10

**FESTA**

LYŽICA NEREZ

INOX

Č.p.	špecifikácia		Č.p.	špecifikácia	
31220	120 x 80 mm	10	31222	160 x 115 mm	10
31221	140 x 80 mm	10	31231	180 x 120 mm	10

**FESTA**

LYŽICA NEREZ OBLÁ

· gumová rukoväť

INOX

Č.p.	špecifikácia	
31334	160 x 100 mm	10

**FESTA**

LYŽICA NEREZ OBLÁ

INOX

Č.p.	špecifikácia	
31343	160 x 100 mm	10

**FESTA**

LYŽICA NEREZ VYMAZÁVACIA

· gumová rukoväť

INOX

Č.p.	špecifikácia		Č.p.	špecifikácia	
31360	40 mm	10	31400	100 mm	10
31380	60 mm	10	31403	120 mm	10
31390	80 mm	10			

**FESTA**

LYŽICA NEREZ VYMAZÁVACIA

INOX

Č.p.	špecifikácia		Č.p.	špecifikácia	
31362	40 mm	10	31392	80 mm	10
31382	60 mm	10	31402	100 mm	10
			31404	120 mm	10



FESTA

LYŽICA NEREZ MAČACÍ JAZYK

· gumová rukoväť

INOX

Č.p.	špecifikácia	
31330	140 x 50 mm	10
31340	160 x 60 mm	10



FESTA

LYŽICA NEREZ MAČACÍ JAZYK

INOX

Č.p.	špecifikácia	
31332	140 x 50 mm	10
31341	160 x 60 mm	10



FESTA

LYŽICA NEREZ KÚTOVÁ

· gumová rukoväť

INOX

Č.p.	špecifikácia	
31280	80 x 60 x 60 mm	10



FESTA

LŽICE NEREZ KÚTOVÁ

INOX

Č.p.	špecifikácia	
31281	80 x 60 x 60 mm	10



FESTA

LYŽICA NEREZ ROHOVÁ

· gumová rukoväť

INOX

Č.p.	špecifikácia	
31270	80 x 60 x 60 mm	10



FESTA

LYŽICA NEREZ ROHOVÁ

INOX

Č.p.	špecifikácia	
31271	80 x 60 x 60 mm	10



FESTA

LYŽICA NEREZ POKRÝVAČSKÁ

· gumová rukoväť

INOX

Č.p.	špecifikácia	
31320	140 x 75 mm	10



FESTA

LYŽICA NEREZ POKRÝVAČSKÁ

INOX

Č.p.	špecifikácia	
31322	140 x 75 mm	10

**FESTA****LŽÍCE NEREZ ZUBOVÁ S HRANOU****INOX**

Č.p.	špecifikácia	
31218	180 mm e 6	12

**FESTA****ŠPACHTĽA NEREZ**

· gumová rukoväť

INOX

Č.p.	špecifikácia		Č.p.	špecifikácia	
31510	40 mm	10	31513	100 mm	10
31511	60 mm	10	31514	120 mm	10
31512	80 mm	10	31515	140 mm	10

**FESTA****ŠPACHTĽA NEREZ****INOX**

Č.p.	špecifikácia		Č.p.	špecifikácia	
31461	40 mm	12	31491	100 mm	12
31471	60 mm	12	31467	120 mm	12
31481	80 mm	12	31468	140 mm	12

**FESTA****ŠPACHTĽA ŠKRABACIA NEREZ**

· zosilnená čepeľ

INOX

Č.p.	špecifikácia	
32173	75 mm	10

**FESTA****ŠPACHTĽA ŠKRABACIA NEREZ S TULEJOU**· zosilnená čepeľ
· vhodná násada 52010**INOX**

Č.p.	špecifikácia	
32170	100 mm	12

**FESTA****ŠPACHTĽA NEREZ S BITOM**

· gumová rukoväť

INOX

Č.p.	špecifikácia	
31455	150 mm	12
31456	200 mm	12

**FESTA****STIERKA NEREZ S VÝSTUŽOU**

· gumová rukoväť

INOX

Č.p.	špecifikácia	
31505	200 mm	5
31506	250 mm	5
31507	300 mm	5



FESTA

ŠPACHTĽA NEREZ PRE CELOPLOŠNÉ TMELENIE

INOX

Č.p.	špecifikácia	
31555	35 cm	1
31556	45 cm	1
31557	60 cm	1

Č.p.	špecifikácia	
31558	80 cm	1
31559	100 cm	1

NEW



FESTA

DRŽIAK ŠPACHTĽE PRE CELOPLOŠNÉ TMELENIE

· pre 31555 - 31559
· násada 52010, 52011, 52012, 52020, 52030

Č.p.	špecifikácia	
31610		1

NEW



FESTA

NÁSADA TELESKOPICKÁ

· závit pro 31610, 34203

Č.p.	špecifikácia	
52011	88 - 140 cm	1



STIERKA NEREZ S VÝSTUŽOU

INOX

MADE IN
EU

Č.p.	špecifikácia	
31520	400 mm	1
31521	500 mm	
31522	600 mm	

31523



násada 61254

31524



STIERKA NEREZ S VÝSTUŽOU-PRÍSLUŠENSTVO

MADE IN
EU

Č.p.	špecifikácia	
31523	držiak ALU	1
31524	držiak plastic	1



FESTA

STIERKA NEREZ FASÁDNA

INOX

Č.p.	špecifikácia	
31552	400 mm	10
31553	600 mm	10



STIERKA NEREZ

INOX

MADE IN
EU

Č.p.	špecifikácia	
31541	250 mm	1
31551	250 mm úzka	1



FESTA

ŠPACHTĽA NEREZ

INOX

Č.p.	špecifikácia	
31498	150 mm	12
31499	200 mm	12
31500	100 mm	12



ŠPACHTĽA NEREZ

INOX

MADE IN
EU

Č.p.	špecifikácia	
31493	40 mm	20
31494	60 mm	20
31495	80 mm	20
31496	100 mm	20



FESTA

ŠPACHTĽA OCEĽOVÁ

Č.p.	špecifikácia	
32161	30 mm	10
32162	40 mm	10
32163	50 mm	10
32164	60 mm	10
32169	70 mm	10
32165	80 mm	10



FESTA

ŠPACHTĽA ŠKRABACIA NA STENY A PODLAHY

· zosilnená čepeľ

INOX

Č.p.	šírka	dĺžka	
32174	100 mm	500 mm	1



ŠPACHTĽA OCEĽOVÁ

Č.p.	špecifikácia	
32176	30 mm	12
32186	40 mm	12
32196	50 mm	12
32206	60 mm	12

Č.p.	špecifikácia	
32216	80 mm	12
32226	100 mm	12
32234	125 mm	12

SADA ŠPACHTĽÍ OCEĽOVÝCH

3x

Č.p.	špecifikácia	
32240	30, 50, 80 mm	10





HLADIDLO OCEĽOVÉ

Č.p.	špecifikácia	
32062	280 x 160 mm	10
32076	400 x 100 mm	36
32060	500 x 140 mm	5



HLADIDLO OCEĽOVÉ ŠPICATÉ

Č.p.	špecifikácia	
32064	500 x 90 mm	5
32066	550 x 140 mm	5



LYŽICA OCEĽOVÁ BRÚSENÁ

Č.p.	špecifikácia	
32015	160 x 130 mm	10
32014	180 x 130 mm	10
32016	200 x 140 mm	10



LYŽICA OCEĽOVÁ

Č.p.	špecifikácia	
32001	160 x 110 mm	10
32002	160 x 130 mm	10
32003	180 x 130 mm	10
32013	200 x 140 mm	10



LYŽICA OCEĽOVÁ OBLÁ

Č.p.	špecifikácia	
32018	160 x 110 mm	10



LYŽICA OCEĽOVÁ VYMAZÁVACIA

Č.p.	špecifikácia	
32024	140 x 80 mm	12



LYŽICA OCEĽOVÁ MAČACÍ JAZYK

Č.p.	špecifikácia	
32020	140 x 65 mm	12
32021	140 x 40 mm	12



LYŽICA OCEĽOVÁ POKRÝVAČSKÁ

Č.p.	špecifikácia	
32026	140 x 85 mm	12



FESTA

NABERAČKA MURÁRSKA S RÚČKOU, NEREZ

INOX

Č.p.	špecifikácia	
32285	Ø 180 mm	1



FESTA

NABERAČKA MURÁRSKA S RÚČKOU, POZINK

Zn

Č.p.	špecifikácia	
32265	Ø 180 mm	10



FESTA

NABERAČKA MURÁRSKA S RÚČKOU

Č.p.	špecifikácia	
32273	Ø 160 mm	10
32283	Ø 180 mm	10
32293	Ø 215 mm	10



NABERAČKA MURÁRSKA PLASTOVÁ



Č.p.	špecifikácia	
32270	Ø 160 mm	1



NABERAČKA MURÁRSKA OCEĽ

· vhodná násada 61215

Č.p.	špecifikácia	
32302	Ø 180 mm	1
32313	Ø 215 mm	1
32301	Ø 235 mm	1



NABERAČKA MURÁRSKA OCEĽ S RÚČKOU PRE LOPATOVÚ NÁSADU

· vhodná násada 61200, 61201

Č.p.	špecifikácia	
32268	Ø 215 mm	1
32269	Ø 235 mm	1
32296	Ø 215 mm	1



NABERAČKA MURÁRSKA OCEĽ S NÁSADOU

MOQ 3

Č.p.	špecifikácia	
32295	Ø 180 mm dĺžka násady 160 cm	3
32297	Ø 215 mm dĺžka násady 160 cm	3
32298	Ø 235 mm dĺžka násady 160 cm	3



HRABLO NA BETÓN

Č.p.	špecifikácia	
60100	hrablo na betón 295 x 150 mm	24
61169	hrablo s násadou 160 cm	3
61218	násada 160 cm	5

**FESTA**

ŠPACHTĽA NEREZ MALIARSKA

INOX

Č.p.	špecifikácia	
31497	63 x 195 mm	12

**FESTA**

NŮŽ NEREZ TAPETÁRSKÝ

INOX

Č.p.	špecifikácia	
31503	150 mm	12



ŠPACHTĽA ŠKRABACIA MALIARSKA

MADE IN EU

Č.p.	špecifikácia	
31501	100 mm	30
31502	náhradný brit	1



ŠPACHTĽA PRE SADROKARTONÁROV

PLASTIC

Č.p.	špecifikácia	
34308	50 mm	20
34307	80 mm	12
34306	100 mm	10
34305	150 mm	12

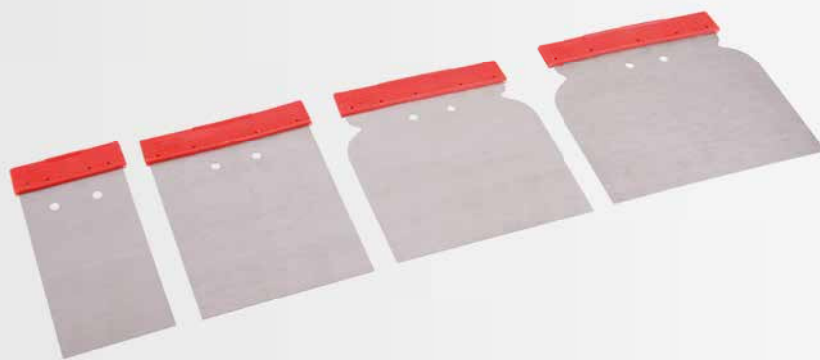
**FESTA**

STIERKA JAPONSKÁ

4x

Č.p.	špecifikácia	
31452	nerez 50, 80, 100, 120 mm	10
31453	ocel' 50, 80, 100, 120 mm	10

FESTA

STIERKA JAPONSKÁ, PLAST

PLASTIC 4x

Č.p.	špecifikácia	
31454	50, 80, 100, 120 mm	12



STIERKA OCEĽOVÁ

Č.p.	špecifikácia	
31601	180 mm - rovná	1
31602	180mm A1	1
31603	180mm A2	1
31641	180 mm - e4	1



STIERKA OCEĽOVÁ

Č.p.	špecifikácia	
31651	250 mm - rovná	1
31655	250 mm - e4	1



STIERKA PLASTOVÁ ZUBOVÁ

Č.p.	špecifikácia	
37101	150 x 80 mm	100
37111	170 x 115 mm	100



STIERKA PLASTOVÁ

Č.p.	špecifikácia	
37051	rovná	1
37031	zub - 4 x 6 mm	1
37041	zub - 6 x 6 mm	1



LYŽICA OCEĽOVÁ MODELOVACIA

Č.p.	špecifikácia	
32022	140 x 80 mm	12
32023	125 x 40 mm	12

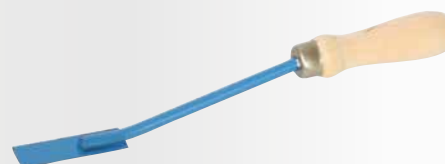

ŠPÁROVAČKA JEDNOSTRANNÁ

Č.p.	špecifikácia	
32040	10 mm	20
32041	12 mm	20
32042	15 mm	20
32043	18 mm	20
32044	20 mm	20



ŠPÁROVAČKA OBOJSTRANNÁ

Č.p.	špecifikácia	
32050	10 12 mm	50
32051	10 15 mm	50
32052	10 18 mm	50
32053	15 20 mm	50



DRÁŽKOVACĤ NA YTONG

Č.p.	špecifikácia	
32037	600 mm	1

**FESTA**

ŠKRABÁK NA YTONG

topoľ

MOQ
2

Č.p.	špecifikácia
32317	450 x 95 mm



2

**FESTA**

ŠKRABÁK NA YTONG - JEMNÝ ZUB

topoľ

MOQ
2

Č.p.	špecifikácia
32312	450 x 95 mm

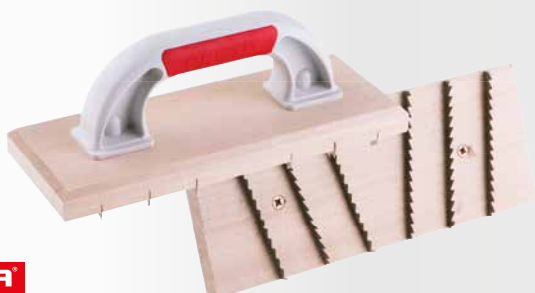

2

**FESTA**

ŠKRABÁK NA YTONG

topoľ

MOQ
2

Č.p.	špecifikácia
32337	260 x 95 mm



2

**FESTA**

ŠKRABÁK NA YTONG - JEMNÝ ZUB

topoľ

MOQ
2

Č.p.	špecifikácia
32338	260 x 95 mm



2

**FESTA**

ŠKRABÁK NA YTONG

topoľ

MOQ
2

Č.p.	špecifikácia
32327	230 x 145 mm



2

NEW

ŠKRABÁK NA YTONG

MOQ
2

Č.p.	špecifikácia
32332	450 x 95 mm



2

NEW

ŠKRABÁK NA YTONG

MOQ
2

Č.p.	špecifikácia
32333	230 x 145 mm



2



FESTA

ŠKRABÁK NA STARÉ OMIETKY



Č.p.	špecifikácia
32314	400 x 180 mm



FESTA

ŠKRABÁK NA STARÉ OMIETKY



Č.p.	špecifikácia
32329	270 x 130 mm



FESTA

ŠKRABÁK NA STARÉ OMIETKY S OTVORMI



Č.p.	špecifikácia
33168	380 x 160 mm

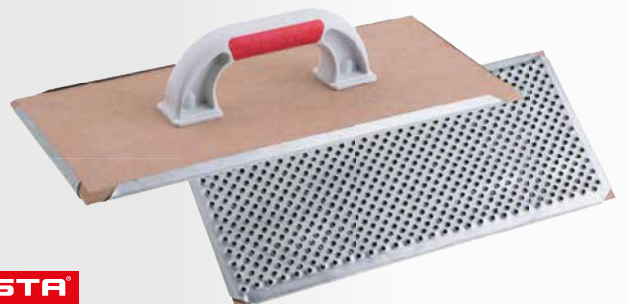

FESTA

ŠKRABÁK NA STARÉ OMIETKY



Č.p.	špecifikácia
32320	400 x 180 mm



NEW



ŠKRABÁK NA STARÉ OMIETKY



Č.p.	špecifikácia
32311	400 x 180 mm



FESTA

HLADIDLO BRÚSNE NA POLYSTYRÉN



Č.p.	špecifikácia
32418	400 x 180 mm hr. 16
32421	400 x 180 mm hr. 16 brusný papier



FESTA

HLADIDLO BRÚSNE NA POLYSTYRÉN



Č.p.	špecifikácia
32318	400 x 180 mm
32319	500 x 250 mm
32321	400 x 180 mm hr. 16 brusný papier
32322	500 x 250 mm hr. 16 brusný papier



FESTA

HLADIDLO BRÚSNE NA POLYSTYRÉN



Č.p.	špecifikácia
32324	270 x 130 mm hr. 16
32323	270 x 130 mm hr. 16 brusný papier



**FESTA**

HLADIDLO BRÚSNE S LEPENÝM BRUSIVOM

MADE IN
EUMOQ
2

Č.p.	špecifikácia	
32330	400 x 180 mm	2
32331	270 x 130 mm	2

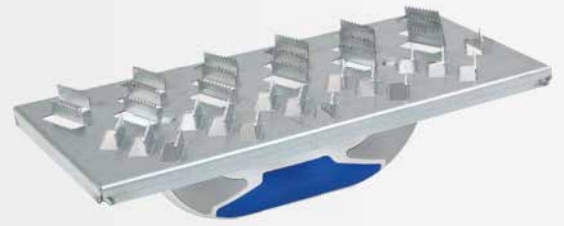
ŠKRABÁK PLECHOVÝ NA KAMENNÚ
MINERÁLNU VLNUZn
MADE IN
EUMOQ
2

Č.p.	špecifikácia	
32328	285 x 145 mm	10

**FESTA**

ŠKRABÁK PLECHOVÝ

MADE IN
EUMOQ
2

Č.p.	špecifikácia	
32325	225 x 105 mm	2

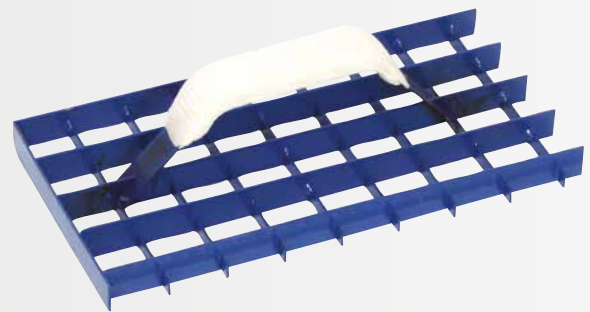

ŠKRABÁK MRIEŽKOVÝ

MOQ
2

Č.p.	špecifikácia	
32316	280 x 150 mm	20

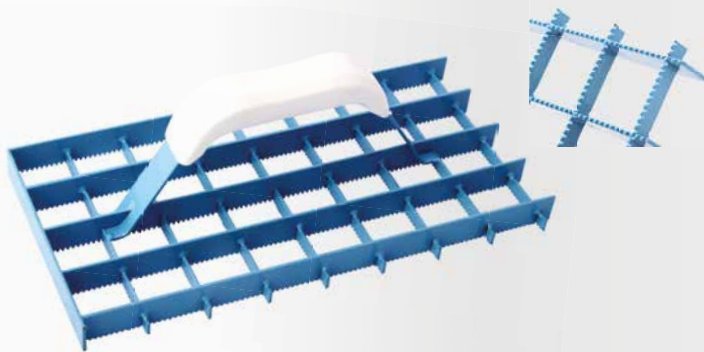

ŠKRABÁK MRIEŽKOVÝ OZUBENÝ

MOQ
2

Č.p.	špecifikácia	
32335	290 x 145 mm	2



ŠKRABÁK

- 8 britov

ALU

MOQ
2

Č.p.	špecifikácia	
32326	450 x 90 mm	20



ŠKRABÁK

- 6 britov

MOQ
2

Č.p.	špecifikácia	
32315	270 x 90 mm	30

NEW



HLADIDLO PLASTOVÉ

MADE IN
EU

Č.p.	špecifikácia	
34028	400 x 180 mm	20



FESTA
HLADIDLO PLASTOVÉ



Č.p.	špecifikácia	
34027	400 x 180 mm	20

FESTA
HLADIDLO PLASTOVÉ BEZ POVRCHU



Č.p.	špecifikácia	
30003	270 x 125 mm	28
30004	235 x 115 mm	35
30005	210 x 115 mm	38
30007	210 x 60 mm	44



FESTA
HLADIDLO DREVENÉ

lipové drevo



Č.p.	špecifikácia	
34005	400 x 145 mm	40
34007	290 x 145 mm	20



HLADIDLO DREVENÉ

topoľové drevo



Č.p.	špecifikácia	
34006	400 x 145 mm	40



FESTA
HLADIDLO ABS



Č.p.	špecifikácia	
34041	280 x 140 - 2 mm	10
34051	280 x 140 - 3 mm	10
34053	280 x 140 - 3 mm zubové - e6	10



HLADIACA DOSKA NA BETÓN



Č.p.	špecifikácia	
15889	980 x 380 mm násada Ø 32 mm	1



STIERKA S GUMOU

Č.p.	špecifikácia	
15886	450 mm násada Ø 23 mm	48
15887	600 mm násada Ø 23 mm	48
15888	750 mm násada Ø 23 mm	32



SŤAHOVACIA DOSKA



Č.p.	špecifikácia	
15885	100 x 800 mm násada Ø 32 mm	1

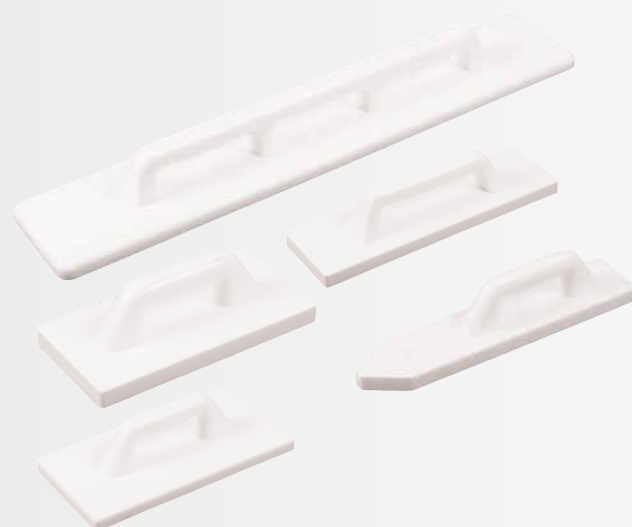

HLADIDLO POLYURETAN



Č.p.	špecifikácia	
34122	120 x 240 mm	50
34132	140 x 280 mm	40
34142	180 x 320 mm	25
34152	200 x 360 mm	20
34121	80 x 260 mm skosené	50
34153	100 x 400 mm	30

Č.p.	špecifikácia	
34154	220 x 420 mm	15
34155	240 x 480 mm	15
34156	280 x 500 mm	10
34157	330 x 330 mm	5
34158	120 x 800 mm	5
34159	120 x 1000 mm	5
34160	120 x 1200 mm	5

HLADIDLO POLYSTYREN



Č.p.	špecifikácia	
34101	80 x 350 mm skosené	10
34061	130 x 270 mm	10
34111	170 x 320 mm	10
34071	130 x 450 mm	10
34081	140 x 750 mm	10
34091	140 x 900 mm	5



HLADIDLO POLYURETAN



Č.p.	špecifikácia	
34115	140 x 280 mm	36
34116	180 x 320 mm	36
34117	200 x 360 mm	24
34118	220 x 420 mm	24



HLADIDLO NA BRÚSNU MREŽKU

Č.p.	špecifikácia	
34301	230 x 105 mm	1
34304	235 x 80 mm	1



FESTA

HLADIDLO NA BRÚSNU MREŽKU

Č.p.	špecifikácia	
34200	210 x 115 mm	30
34201	240 x 105 mm	50
34202	240 x 80 mm	50



HLADIDLO NA NÁSADU NA BRÚSNU MREŽKU

· násada 52030

ALU

Č.p.	špecifikácia	
34203	230 x 80 mm aluminium	1
52030	teleskopická násada	12

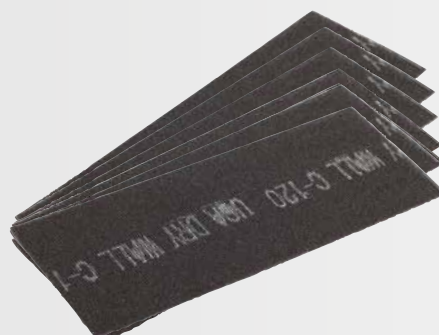

MREŽKA BRÚSNA SADA

10x

Č.p.	špecifikácia	
34271	115 x 290 mm zrn. 120	80
34272	115 x 290 mm zrn. 100	80
34273	115 x 290 mm zrn. 80	80
34274	93 x 290 mm zrn. 120	80
34275	93 x 290 mm zrn. 100	80
34276	93 x 290 mm zrn. 80	80



MREŽKA BRÚSNA SADA

3x

Č.p.	špecifikácia	
34280	115 x 290 mm zrn. 120	20
34281	115 x 290 mm zrn. 100	20
34282	115 x 290 mm zrn. 80	20
34283	93 x 290 mm zrn. 120	20
34284	93 x 290 mm zrn. 100	20
34285	93 x 290 mm zrn. 80	20

MATERIÁL POVRCH	BETÓN		OMIETKA			LEPIDLO A ŠKÁROVACIE HMOTY	FASÁDNE LEPIDLO	POUŽITIE
	HRUBÝ	POTEROVÝ	JADROVÁ	JEMNÁ VNÚTORNÁ	JEMNÁ YTONG			
ČIERNA PLSŤ (HNEDÁ, SIVÁ)				••••		••		vyrovnanie jemnej omietky, na väčšie zrno omietok
BIELA PLSŤ				••••	••••	••••		vyrovnanie jemnej omietky, na jemnejšie zrno omietok
MOLITAN JEMNÝ				••••	••••	••••		odstránenie voľného piesku, na jemný štuk (keraštuk), na umytie obkladov po spárovaní
MOLITAN HRUBÝ				••••	••••	••••		odstránenie voľného piesku, na hrubý štuk
MOLITAN RASTROVANÝ				••••	••••	••••		odstránenie voľného piesku, vďaka rastrovaniu lepšie zachytí hrubé časti štku, na umytie po spárovaní
MORSKÁ HUBA					•••		••••	umytie škárovacej hmoty
HYDRO HUBA HRUBÁ, JEMNÁ					•		••••	umytie škárovacej hmoty
HUBA				••	••••	••	••••	umytie škárovacej hmoty, dočistenie jemnej omietky, vyhladenie štukových omietok
MIKROPRYŽ							••••	zatlačenie škárovacej hmoty do škáry
GUMOVÁ PENA							••••	zatlačenie škárovacej hmoty do škáry
MIRELON		••••	•••					spracovanie betónu, zapucovanie jadra
DUREN				••••	••	••••		vyrovnanie jemnej omietky, všeobecne na dokončenie štukových omietok
DREVO	••••	••••	••••					spracovanie betónu, zapucovanie jadra
OCEĽOVÝ PLECH	••	••••		••		••••	••	glejtovanie betónu, nedostupné miesta
POLYSTYRÉN	•••	••••	•••	••		••		spracovanie betónu, zapucovanie jadra
POLYURETÁN	••••	••••	••••					spracovanie betónu, zapucovanie jadra
ABS		••		••••	••••	••••	••••	škrabanie a točená omietka, nanášanie lepidla, omietok a štukov, ťahovanie jemné, špalety
NEREZ HLADKÉ				••••	••••	••••	••••	ťahovanie jemné, nanášanie lepidiel, omietok a štukov, ťahovanie fasádneho lepidla
NEREZ ZUBATÉ							••••	ťahovanie lepidla na obklady a dlažbu
BRÚSNE HĽADIDLO NA POLYSTYRÉN, PLASTOVÉ			••				••••	brúsenie polystyrénu, brúsenie cementového lepidla
BRÚSNE HĽADIDLO NA POLYSTYRÉN, PREGLEJKOVÉ			••				••••	brúsenie fasádneho polystyrénu, brúsenie cementového lepidla

**FESTA**

HLADIDLO PLASTOVÉ BIELA PLŠŤ



Č.p.	špecifikácia		Č.p.	špecifikácia	
34400	280 x 140 x 8 mm	15	34450	220 x 130 x 8 mm	15
34415	250 x 130 x 8 mm	15	34445	220 x 70 x 8 mm	20

**FESTA**

HLADIDLO PLASTOVÉ PLŠŤ ČIERNA



Č.p.	špecifikácia		Č.p.	špecifikácia	
34401	280 x 140 x 10 mm	15	34451	220 x 130 x 10 mm	15
34416	250 x 130 x 10 mm	15	34446	220 x 70 x 10 mm	20

**FESTA**

HLADIDLO PLASTOVÉ S HRUBOU HUBOU



Č.p.	špecifikácia	
34441	280 x 140 x 12 mm	15
34440	250 x 130 x 12 mm	15

**FESTA**

HLADIDLO PLASTOVÉ S JEMNOU HUBOU



Č.p.	špecifikácia		Č.p.	špecifikácia	
34405	280 x 140 x 18 mm	15	34480	280 x 140 x 12 mm	15
34420	250 x 130 x 18 mm	15	34481	250 x 130 x 12 mm	15
34454	220 x 130 x 18 mm	15	34482	220 x 130 x 12 mm	15
34449	220 x 70 x 18 mm	20			

**FESTA**

HLADIDLO PLASTOVÉ S EXTRA JEMNOU HUBOU



Č.p.	špecifikácia	
34443	280 x 140 x 12 mm	15
34442	250 x 130 x 12 mm	15
34439	250 x 130 x 18 mm	15

**FESTA**

HLADIDLO PLASTOVÉ S JEMNÝM MOLITANOM



Č.p.	špecifikácia		Č.p.	špecifikácia	
34404	280 x 140 x 30 mm	10	34419	250 x 130 x 20 mm	10
34485	280 x 130 x 20 mm	10	34453	220 x 130 x 20 mm	10
34486	250 x 130 x 30 mm	10	34447	220 x 70 x 20 mm	10

**FESTA**

HLADIDLO PLASTOVÉ S RASTROVANÝM MOLITANOM



Č.p.	špecifikácia	
34409	280 x 140 x 30 mm	10
34425	250 x 130 x 20 mm	10

**FESTA**

HLADIDLO PLASTOVÉ S HRUBÝM MOLITANOM



Č.p.	špecifikácia	
34410	280 x 140 x 30 mm	10
34426	250 x 130 x 20 mm	10



FESTA

HLADIDLO PLASTOVÉ S MORSKOU HUBOU



Č.p.	špecifikácia	
34406	280 x 140 x 30 mm	10
34421	250 x 130 x 30 mm	10
34455	220 x 130 x 30 mm	10



FESTA

HLADIDLO PLASTOVÉ S MORSKOU HUBOU, RASTROVANOU



Č.p.	špecifikácia	
34413	280 x 140 x 30 mm	10
34428	250 x 130 x 30 mm	10



FESTA

HLADIDLO PLASTOVÉ S HYDRO HUBOU HRUBOU



Č.p.	špecifikácia	
34412	280 x 140 x 30 mm	10
34424	250 x 130 x 30 mm	10
34458	220 x 130 x 30 mm	10



FESTA

HLADIDLO PLASTOVÉ S HYDRO HUBOU, HRUBOU, RASTROVANÉ



Č.p.	špecifikácia	
34490	280 x 140 x 30 mm	10
34491	250 x 130 x 30 mm	10



FESTA

HLADIDLO PLASTOVÉ S HYDRO HUBOU JEMNOU



Č.p.	špecifikácia	
34411	280 x 140 x 30 mm	10
34423	250 x 130 x 30 mm	10
34457	220 x 130 x 30 mm	10



FESTA

HLADIDLO PLASTOVÉ S GUMOVOU PENOU

Č.p.	špecifikácia	
34402	280 x 140 x 10 mm	15
34417	250 x 130 x 10 mm	15
34452	220 x 130 x 10 mm	15



FESTA

HLADIDLO PLASTOVÉ S MIKROPŘYŽOU

Č.p.	špecifikácia	
34403	280 x 140 x 8 mm	15
34418	250 x 130 x 8 mm	15
34496	220 x 130 x 8 mm	15

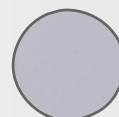

FESTA

HLADIDLO PLASTOVÉ - DUREN



Č.p.	špecifikácia	
34407	280 x 140 x 20 mm	10
34422	250 x 130 x 20 mm	10
34456	220 x 130 x 20 mm	10
34448	220 x 70 x 20 mm	10

FESTA
HLADIDLO PLASTOVÉ - RUVEN



Č.p.	špecifikácia	
34414	280 x 140 x 20 mm	10
34429	250 x 130 x 20 mm	10
34459	220 x 130 x 20 mm	10
34479	220 x 70 x 20 mm	10

FESTA
HLADIDLO PLAST BEZ POVRCHU

Č.p.	špecifikácia	
30003	270 x 125 mm	28
30004	235 x 115 mm	35
30005	210 x 115 mm	38
30007	210 x 60 mm	44

FESTA
HLADIDLO ŠKÁROVACIE

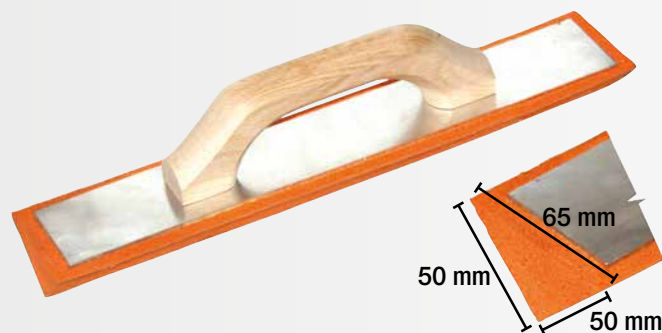
Č.p.	špecifikácia	
34033	240 x 95 mm	5

HLADIDLO KÚTOVÉ S HUBOU 90°

Č.p.	špecifikácia	
34500	350 mm	6

NÁHRADNÝ POVRCH - BIELA PLŠŤ

Č.p.	špecifikácia	
34241	280 x 140 x 8 mm	1
34223	250 x 130 x 8 mm	1

NÁHRADNÝ POVRCH - ČIERNA PLŠŤ

Č.p.	špecifikácia	
34243	280 x 140 x 10 mm	1
34221	250 x 130 x 10 mm	1

NÁHRADNÝ POVRCH - JEMNÁ HUBA

Č.p.	špecifikácia	
34262	280 x 140 x 18 mm	1



NÁHRADNÝ POVRCH - JEMNÝ MOLITAN

Č.p.	špecifikácia	
34251	280 x 140 x 30 mm	1



NÁHRADNÝ POVRCH - HRUBÝ MOLITAN



Č.p.	špecifikácia	
34261	280 x 140 x 30 mm	1

NÁHRADNÝ POVRCH - MORSKÁ HUBA



Č.p.	špecifikácia	
34265	280 x 140 x 30 mm	1

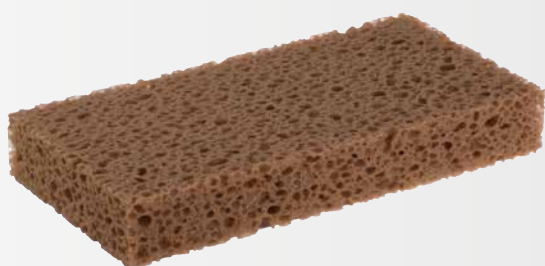

NÁHRADNÝ POVRCH - HYDRO HUBA HRUBÁ



Č.p.	špecifikácia	
34238	280 x 140 x 30 mm	1

NÁHRADNÝ POVRCH - HYDRO HUBA JEMNÁ



Č.p.	špecifikácia	
34237	280 x 140 x 30 mm	1
34235	250 x 130 x 30 mm	1



NÁHRADNÝ POVRCH - GUMOVÁ PENA



Č.p.	špecifikácia	
34231	280 x 140 x 10 mm	1

FESTA**ELEKTRICKÉ MIEŠADLO STAVEBNÝCH ZMESÍ DVOJMETĽOVÉ**

Príkon	1800 W
Napätie/frekvencia	230 V / 50 Hz
Rýchlostné stupne	2
1. stupeň (voľnobežné otáčky)	0 - 450 ot./min.
2. stupeň (voľnobežné otáčky)	0 - 790 ot./min.
Ochrana proti preťaženiu	Ano
Priemer miešacieho koša	100 mm
Dĺžka miešacej metly	570 mm
Hmotnosť	5,6 kg



Č.p.	špecifikácia	
35311	miešadlo	1
35318	náhradný uhlík	1
35319	miešadlá náhradné - pár (L+P)	1

**FESTA****ELEKTRICKÉ MIEŠADLO STAVEBNÝCH ZMESÍ 850 W**

Príkon	850 W
Napätie/frekvencia	230 V / 50 Hz
Rýchlostné stupne	1
1. stupeň (voľnobežné otáčky)	0 - 500 ot./min.
2. stupeň (voľnobežné otáčky)	-
Ochrana proti preťaženiu	Ano
Závit míchací metly	M 14
Priemer miešacieho koša	120 mm
Dĺžka miešacej metly	600 mm
Hmotnosť	3,7 kg

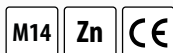

Č.p.	špecifikácia	
35300		1
35316	náhradný uhlík	1

**FESTA****ELEKTRICKÉ MIEŠADLO STAVEBNÝCH ZMESÍ 1600 W**

Príkon	1600 W
Napätie/frekvencia	230 V / 50 Hz
Rýchlostné stupne	2
1. stupeň (voľnobežné otáčky)	0 - 480 ot./min.
2. stupeň (voľnobežné otáčky)	0 - 800 ot./min.
Ochrana proti preťaženiu	Ano
Závit míchací metly	M 14
Priemer miešacieho koša	140 mm
Dĺžka miešacej metly	600 mm
Hmotnosť	4,7 kg

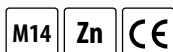

Č.p.	špecifikácia	
35310		1
35317	náhradný uhlík	1



FESTA**MIEŠADLO S KRUHOM PRAVOTOČIVÉ**

Špirálová metla s tromi ramenami a krúžkom pravotočivá - pre ťažké materiály s vysokou viskozitou. Malty, betóny, cementové a vápenné omietky, spojovacie hmoty, mazaniny, epoxidové živice, živičné vrstvy- Miešací účinok odspodu nahor - metla sa ako skrutka vťahuje do materiálu.

Zn M14

Č.p.	špecifikácia	
35085	M14 Ø 120 x 600 mm	12
35086	M14 Ø 140 x 600 mm	12
35087	M14 Ø 160 x 600 mm	12

FESTA**MIEŠADLO S KRUHOM ĽAVOTOČIVÉ**

Špirálová metla s tromi ramenami a krúžkom ľavotočivá - pre riedke tekuté zmesi vo veľkom množstve. Miešaný materiál je tlačný nadol. Riedky tekutý materiál nestrieka z nádoby, usadené pigmenty farieb sa dostávajú nahor a ideálne sa premiešajú.

Zn M14

Č.p.	špecifikácia	
35091	M14 Ø 120 x 600 mm	12
35092	M14 Ø 140 x 600 mm	12
35093	M14 Ø 160 x 600 mm	12

FESTA**MIEŠADLO S KRUHOM**

Špirálová metla s dvoma ramenami - pre dôkladné rozmiešanie lepidiel na obklady, špárovacích hmôt, lepiacich mált, hotových omietok, mazaniny, stierkovacích hmôt, vyrovnávacích hmôt.

**Zn**

Č.p.	špecifikácia	
35038	Ø 80 x 500 mm	24
35058	Ø 100 x 500 mm	24
35023	Ø 120 x 500 mm	24

FESTA**MIEŠADLO S KRUHOM**

Špirálová metla s dvoma ramenami - pre dôkladné rozmiešanie lepidiel na obklady, špárovacích hmôt, lepiacich mált, hotových omietok, mazaniny, stierkovacích hmôt, vyrovnávacích hmôt.

SDS+**Zn**

Č.p.	špecifikácia	
35094	Ø 80 x 500 mm	24
35095	Ø 100 x 500 mm	24
35096	Ø 120 x 500 mm	24

FESTA**MIEŠADLO S KRUHOM**

Špirálová metla s dvoma ramenami - pre dôkladné rozmiešanie lepidiel na obklady, špárovacích hmôt, lepiacich mált, hotových omietok, mazaniny, stierkovacích hmôt, vyrovnávacích hmôt.

M14 **Zn**

Č.p.	špecifikácia
35059	M14 Ø 90 x 550 mm



24

FESTA**MIEŠADLO S KRUHOM, PREDLŽENÁ ŠPIRÁLA**

Špirálová metla s dvoma ramenami - pre dôkladné rozmiešanie lepidiel na obklady, špárovacích hmôt, lepiacich mált, hotových omietok, mazaniny, stierkovacích hmôt, vyrovnávacích hmôt.

Zn

Č.p.	špecifikácia
35013	Ø 80 x 500 mm
35006	Ø 100 x 500 mm
35007	Ø 120 x 500 mm



24

24

24

FESTA**MIEŠADLO S KRUHOM, PREDLŽENÁ ŠPIRÁLA**

Špirálová metla s dvoma ramenami - pre dôkladné rozmiešanie lepidiel na obklady, špárovacích hmôt, lepiacich mált, hotových omietok, mazaniny, stierkovacích hmôt, vyrovnávacích hmôt.

SDS+ **Zn**

Č.p.	špecifikácia
35012	Ø 100 x 500 mm



24

FESTA**MIEŠADLO ŠPIRÁLA DRÔT**

Špirálová metla s dvoma ramenami - pre dôkladné rozmiešanie lepidiel na obklady, špárovacích hmôt, lepiacich mált, hotových omietok, mazaniny, stierkovacích hmôt, vyrovnávacích hmôt.

Zn

Č.p.	špecifikácia
35069	Ø 60 x 500 mm
35078	Ø 80 x 500 mm
35081	Ø 100 x 500 mm



50

24

24

FESTA

MIEŠADLO ŠPIRÁLA DRÔT

Špirálová metla s dvoma ramenami - pre dôkladné rozmiešanie lepidiel na obklady, špárovacích hmôt, lepiacich mált, hotových omietok, mazaniny, stierkovacích hmôt, vyrovnávacích hmôt.

SDS+ Zn



Č.p.	špecifikácia	
35070	Ø 60 x 500 mm	50
35079	Ø 80 x 500 mm	24
35082	Ø 100 x 500 mm	24

FESTA

MIEŠADLO BEZ KRUHU

Špirálová metla s dvoma ramenami - pre dôkladné rozmiešanie lepidiel na obklady, špárovacích hmôt, lepiacich mált, hotových omietok, mazaniny, stierkovacích hmôt, vyrovnávacích hmôt.

Zn



Č.p.	špecifikácia	
35048	Ø 70 x 500 mm	24
35068	Ø 90 x 500 mm	24

FESTA

MIEŠADLO BEZ KRUHU

Špirálová metla - pre vysoko viskózne a lepkavé materiály, ako sú stavebné lepidlá a tmely, omietky, podlahové stierky a pod. Materiál prúdi od dna k hladine.

Zn



Č.p.	špecifikácia	
35021	Ø 100 x 500 mm	24

FESTA

MIEŠADLO KALICH

Klietková metla - pre materiály, kde je zavzdušnenie zmesi nežiadúce. Pre riedke vyrovnávacie hmoty, stierkové hmoty, tesniace látky, lepidlá.

Zn



Č.p.	špecifikácia	
35015	Ø 100 x 500 mm	20

FESTA**MIEŠADLO VRTULE**

Vrtulová metla – pre tekuté materiály, farby, laky, nástenné a disperzné kľihy na lepenie tapiet, lepidlá na dlaždice.



Č.p.	špecifikácia	
35011	Ø 80 x 500 mm	50

MIEŠADLO S KRUHOM

Oblúková metla s kruhom – pre dôkladné rozmiešanie nástenných farieb, disperzných farieb, glejov, lakov.



Č.p.	špecifikácia	
35125	Ø 60 x 400 mm	40
35126	Ø 80 x 400 mm	40
35127	Ø 100 x 600 mm	20

MIEŠADLO S KRUHOM LAKOVANÉ

Oblúková metla s kruhom – pre dôkladné rozmiešanie nástenných farieb, disperzných farieb, glejov, lakov.



Č.p.	špecifikácia	
35103	Ø 60 x 400 mm	40
35113	Ø 80 x 400 mm	40
35123	Ø 100 x 600 mm	20

**KÁBEL PREDLŽOVACÍ S NAVIJAKOM**

- Predlžovací prívod s navijakom 25 m - IP20
- H05VV - F 3G 1,5mm², - Vybavený tepelnou poistkou
- Výkon v navinutom stave: 1000 W max.
- Výkon v rozvinutom stave: 3000 W max.
- 4 uzemnené zásuvky s detskou poistkou



Č.p.	špecifikácia	
37760	4 zásuvky dĺžka 25 m, IP 20, 1,5 mm ²	2
37761	4 zásuvky dĺžka 50 m, IP 20, 1,5 mm ²	2

**KÁBEL PREDLŽOVACÍ**

Č.p.	špecifikácia	
37730	max. 3680 W dĺžka 10 m, 1,5 mm ²	8
37731	max. 3680 W dĺžka 20 m, 1,5 mm ²	4

OHRIEVAČ ELEKTRICKÝ

napätie	230V ~50Hz
výkon	3300W
prúdové zaťaženie	14.5A
nastavenie výkonu	30/1650/3300W
teplotný rozsah	5-40°C
krytie	IP24
rozmery	27 x 25.5 x 40cm
hmotnosť	4.8 kg

- Rýchle a efektívne vykurovanie pivníc, dielní, obchodov, párty stanov, skleníkov atď.
- Nespotrebáva kyslík
- Bezpečná prevádzka, plynulá regulácia výkonu, priestorový termostat, ventilátor
- Vyhrevné teleso z nehrdzavejúcej ocele
- Možnosť letného využitia pre ventiláciu bez ohrevu · Nízka hladina hluku
- Kvalitné spracovanie, materiály, robustná oceľová konštrukcia, ľahká a bezpečná manipulácia, dlhá životnosť



Č.p.	špecifikácia
35833	3,3 kW



OHRIEVAČ PLYNOVÝ

plyn	G30-I3B/P
tlak plynu	0.7bar
menovité napätie	230V 50Hz
výkon motora	25W
maximálna spotreba plynu	1.11 Kg/h
maximálny tepelný výkon	15KW
maximálny objem horúceho vzduchu	300m ³ /h

- Rýchle a efektívne vykurovanie pri stavebných prácach, v dielnach, atď.
- Spotrebáva kyslík!
- Priamy ohrev vzduchu s nútenou cirkuláciou - rýchly nástup tepla
- Bezpečná prevádzka, plynulá regulácia výkonu
- Termostat a bezpečnostný ventil proti prehriatiu a úniku plynu
- Vrátane príslušenstva - regulátor a prívodná plynová hadica
- Kvalitné spracovanie, materiály, robustná oceľová konštrukcia, jednoduchá a bezpečná manipulácia, dlhá životnosť



Č.p.	špecifikácia
35845	15 kW



OHRIEVAČ PLYNOVÝ

plyn	g30-i3b/p
tlak plynu	1.5bar
menovité napätie	230v 50hz
výkon motora	70w
maximálna spotreba plynu	2.2kg/h
maximálny tepelný výkon	30kw
maximálny objem horúceho vzduchu	750m ³ /h

- Rýchle a efektívne vykurovanie pri stavebných prácach, v dielnach, atď.
- Spotrebáva kyslík!
- Priamy ohrev vzduchu s nútenou cirkuláciou - rýchly nástup tepla
- Bezpečná prevádzka, plynulá regulácia výkonu
- Termostat a bezpečnostný ventil proti prehriatiu a úniku plynu
- Vrátane príslušenstva - regulátor a prívodná plynová hadica
- Kvalitné spracovanie, materiály, robustná oceľová konštrukcia, jednoduchá a bezpečná manipulácia, dlhá životnosť



Č.p.	špecifikácia
35850	30 kW





Stavebné miešačky pre najnáročnejšie profesionálne použitie

Zubový veniec z liatiny s patentovaným uchytením

Nastaviteľná vôľa zubov

Vysoko kvalitná povrchová úprava

Dvojité uloženie ložísk na dne bubna

Patentovaná ochranná izolácia, kvalitatívne istenie podľa DIN EN ISO 9001

Špeciálne vyvinutý tvar bubna

Ochrana proti striekajúcej vode IP 45

Dodávané v prevedení na 230V aj 400V

PROFESIONÁLNE STAVEBNÉ MIEŠAČKY

Lescha

Lescha

MIEŠAČKA STAVEBNÁ



Č.p.	špecifikácia	
35500	Star 150 - 125 l, 230 V nožná brzda	1



Lescha

MIEŠAČKA STAVEBNÁ



Č.p.	špecifikácia	
35502	EUROMIX 125 l, 230 V	1
35503	EUROMIX 125 l, 400 V	1



Lescha

MIEŠAČKA STAVEBNÁ



Č.p.	špecifikácia	
35501	BX 135 - 125 l, 230 V	1



Lescha

MIEŠAČKA STAVEBNÁ



Č.p.	špecifikácia	
35504	ABM 135 l, 230 V nožná brzda	1



Lescha

MIEŠAČKA STAVEBNÁ



Č.p.	špecifikácia	
35505	SM 145 S - 140 l, 230 V	1
35506	SM 145 S - 140 l, 400 V	1
35507	SM 145 S - 140 l, 230 V nožná brzda	1
35508	SM 145 S - 140 l, 400 V nožná brzda	1



Lescha

MIEŠAČKA STAVEBNÁ



Č.p.	špecifikácia	
35510	SM 165 S - 160 l, 230 V nožná brzda	1
35511	SM 165 S - 160 l, 400 V nožná brzda	1
35512	SM 165 S - 160 l, G benzínová	1





Lescha
MIEŠAČKA STAVEBNÁ



Č.p.	špecifikácia	
35514	SM 185 S - 180 l, 230 V nožná brzda	1
35515	SM 185 S - 180 l, 400 V nožná brzda	1



Lescha
MIEŠAČKA STAVEBNÁ



Č.p.	špecifikácia	
35516	S 180 HR - 180 l, 230 V nožná brzda	1
35517	S 180 HR - 180 l, 400 V nožná brzda	1



Lescha
MIEŠAČKA STAVEBNÁ



Č.p.	špecifikácia		
35524	LB 354 230 V, 1,5 kW		1
35525	LB 354 400 V, 1,5 kW		1
35527	LB 354 Honda G200		1
35532	LB 404 230 V, 1,5 kW		1
35533	LB 404 400 V, 1,5 kW		1
35539	LB 484 Robin EH17B		1
35540	LB 484 Honda GX160LX		1
35542	AT 480 400 V, 1,2 kW		1



Lescha
MIEŠAČKA STAVEBNÁ



Č.p.	špecifikácia		
35552	LHB 1000 400 V		1
35553	LHB 1000 HATZ Diesel		1
35555	LHB 1200 400 V		1



Lescha
MIEŠAČKA STAVEBNÁ



Č.p.	špecifikácia	
35518	S 230 HR - 230 l, 230 V nožná brzda	1
35519	S 230 HR - 230 l, 400 V nožná brzda	1

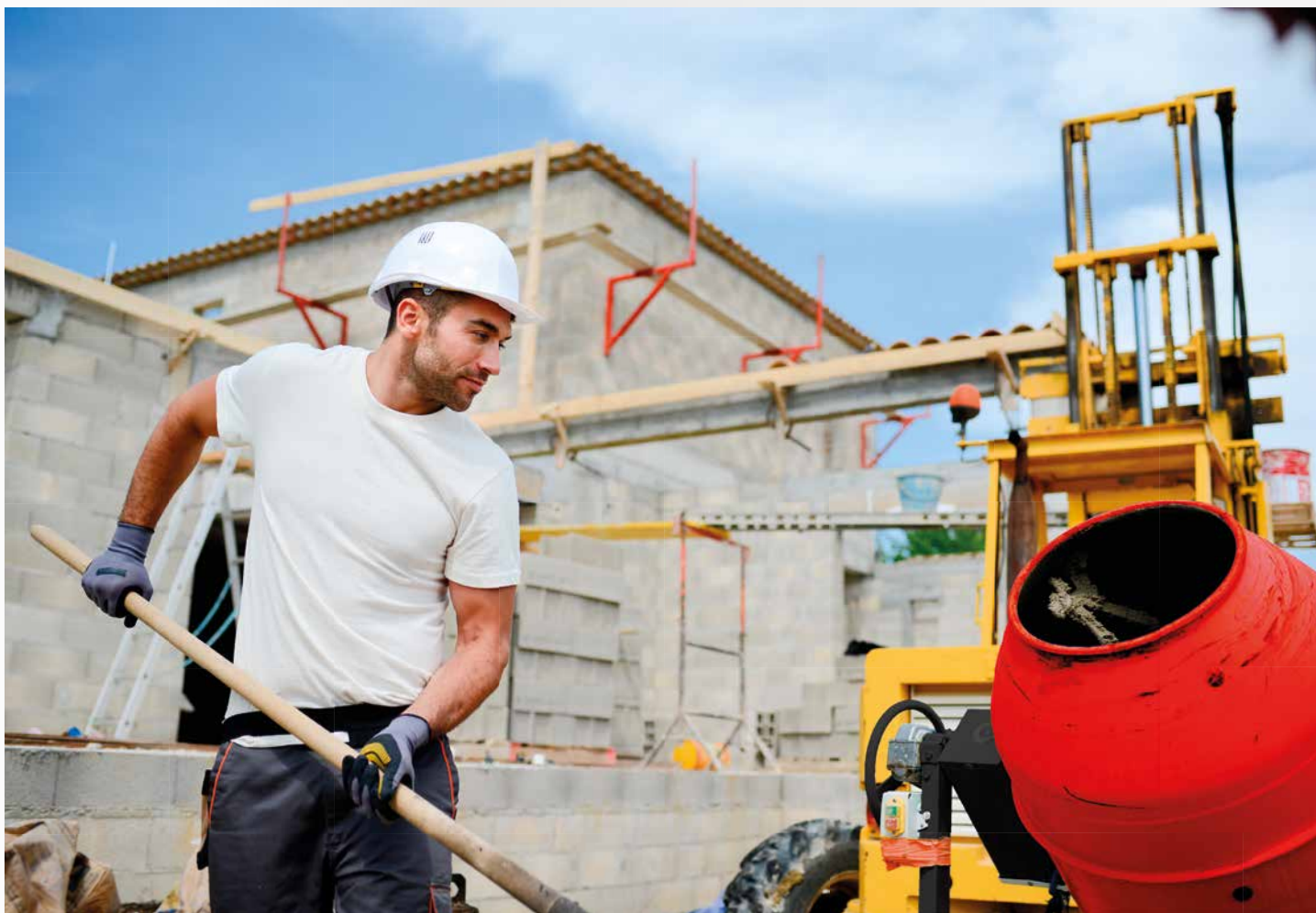

130 L

špecifikácia

objem bubna	130 l
otáčky bubna	26±Min ⁻¹
príkon	700 W
napätie	230 V / 50 Hz
stupeň krytia	IP44
materiál venca	liatinový
rozмеры	dĺžka 1170 mm
	šírka 650 mm
	výška 1280 mm
váha	53 kg

165 L

špecifikácia

objem bubna	165 l
otáčky bubna	23±Min ⁻¹
príkon	900 W
napätie	230 V / 50 Hz
stupeň krytia	IP44
materiál venca	liatinový
rozмеры	dĺžka 1295 mm
	šírka 735 mm
	výška 1440 mm
váha	70 kg



MIEŠAČKA STAVEBNÁ



Č.p.	špecifikácia			
37500	MIX 130Zk	230 V	rozložená	1
37501	MIX 130Z	230 V	zložená	1
37505	MK 165Bk	230 V	rozložená	1
37506	MK 165B	230 V	zložená	1

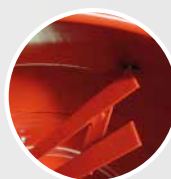

· špeciálne vyrobené lopatky, hrúbka 4 mm



· kvalitné pätné ložisko s krytom



· vypínač s bezpečnostnou krytkou



· plastový kryt pohonu, liatinový veniec

MIEŠAČKA STAVEBNÁ



125 L

špecifikácia	
objem bubna	125 l
otáčky bubna	26±Min ⁻¹
príkon	550 W
napätie	230 V / 50 Hz
stupeň krytia	IP44
materiál venca	liatinový
rozmery	dĺžka 1102 mm
	šírka 690 mm
	výška 1310 mm
váha	52,5 kg

Č.p.	špecifikácia		
37509	126 l, 230 V	zložená	1
37510	126 l, 230 V	rozložená	1

142 L

špecifikácia	
objem bubna	142 l
otáčky bubna	26±Min ⁻¹
príkon	650 W
napätie	230 V / 50 Hz
stupeň krytia	IP44
materiál venca	liatinový
rozmery	dĺžka 1164 mm
	šírka 690 mm
	výška 1293 mm
váha	54 kg

Č.p.	špecifikácia		
37511	142 l, 230 V	rozložená	1
37512	142 l, 230 V	zložená	1

162 L

špecifikácia	
objem bubna	162 l
otáčky bubna	26±Min ⁻¹
príkon	650 W
napätie	230 V / 50 Hz
stupeň krytia	IP44
materiál venca	liatinový
rozmery	dĺžka 1180 mm
	šírka 710 mm
	výška 1310 mm
váha	56 kg

Č.p.	špecifikácia		
37515	162 l, 230 V	rozložená	1
37516	162 l, 230 V	zložená	1

180 L

špecifikácia	
objem bubna	180 l
otáčky bubna	26±Min ⁻¹
príkon	850 W
napätie	230 V / 50 Hz
stupeň krytia	IP44
materiál venca	liatinový
rozmery	dĺžka 1164 mm
	šírka 690 mm
	výška 1368 mm
váha	58 kg

Č.p.	špecifikácia		
37517	180 l, 230 V	rozložená	1
37518	180 l, 230 V	zložená	1

**Lescha**

ZHADZOVANIE STAVEBNEJ SUTE



Č.p.	špecifikácia	
35603	zhoz základný priemer 50/40 cm, dĺžka 108 cm PE (HDPE)	1
35604	násypka zhodu stavebnej sutiny PE (HDPE)	1
35605	nosný rám pre násypku zhodu stavebnej sutiny	1

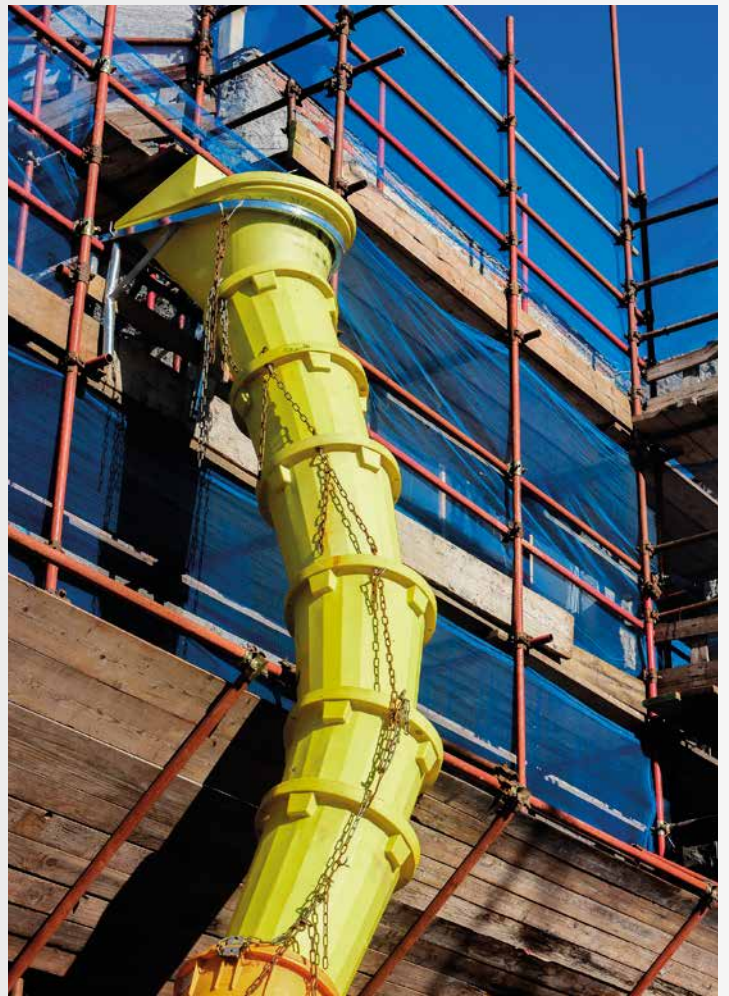

KOLIESKO STAVEBNÉ



Č.p.	špecifikácia	
37530	60 l, Ø 38 cm samonosné koliesko	1
37532	60 l, Ø 40 cm nafukovacie	1



KOLIESKO STAVEBNÉ POZINK



Č.p.	špecifikácia	
37527	80 l, Ø 40 cm nafukovacie	1
37533	80 l, Ø 38 cm samonosné koliesko	1



KORBA ČIERNA



Č.p.	špecifikácia	
37539	60 l	1



KORBA POZINK



Č.p.	špecifikácia	
37541	80 l	1



NÁHRADNÉ KOLESÁ



Č.p.	špecifikácia		
48729	typ AA 400	nafukovacie	1
48730	typ AA 380	samonosné koliesko	1
48731	typ AA 380	samonosné koliesko	1



JAPONKA STAVEBNÁ TROJKOLESOVÁ



Č.p.	špecifikácia		
37564	60 l		1

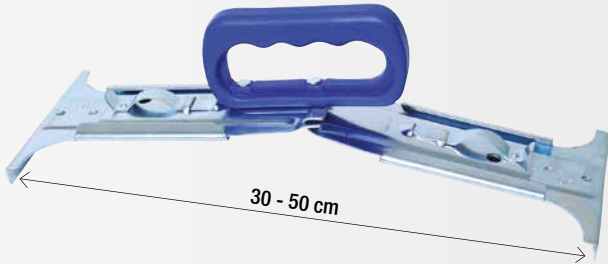

DRŽIAK DLAŽBY NASTAVITELNÝ

Č.p.	špecifikácia		
36310	max. 20kg		5



NOSIČ OBRUBNÍKOV

špecifikácia	60115
rozmer čelustí:	80-370 mm
max. zaťaženie:	50 kg



Č.p.	špecifikácia		
60115	PRO 040		1



NOSIČ OBRUBNÍKOV

špecifikácia	60116
rozmer čelustí:	750-1000 mm
max. zaťaženie:	120 kg



Č.p.	špecifikácia		
60116	PRO 041		1



NOSIČ OBRUBNÍKOV

špecifikácia	60117	60118
rozmer čelustí:	500-1000 mm	0-500 mm
max. zaťaženie:	150 kg	150 kg



Č.p.	špecifikácia		
60117	PRO 042		1
60118	PRO 043		1



KLADIVO PRE VYROVNANIE OBRUBNÍKOV

špecifikácia	60121	60123
výška	200 mm	200 mm
šírka	70 kg	70 kg
dĺžka	870 mm	450 mm
hmotnosť	2,5 kg	2,2 kg



Č.p.	špecifikácia		
60121	870 mm		1
60123	450 mm		1



PODLOŽKA VYROVNÁVACIA POD DLAŽBU



Č.p.	špecifikácia		
37166	D10 základná		25

NEW



FESTA

KOZA SKLADACIA

· maximální nosnosť: 590 kg

Č.p. Špecifikácia

23657



1

NEW



FESTA

PRENOSNÝ STOJANOVÝ ZVERÁK

· rozsah čelústí: 0 - 95 cm
· maximální nosnosť: 250 kg

Č.p. Špecifikácia

37553



1



RUDLA

Č.p.	špecifikácia	nosnosť	
48719	260 mm bantam	250 kg	1

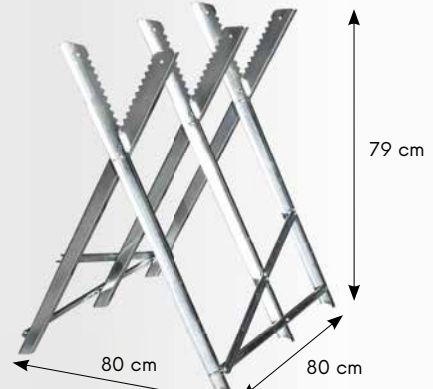

KOZA NA REZANIE DREVA

Č.p.	rozméry	
37570	max. 150 kg	1

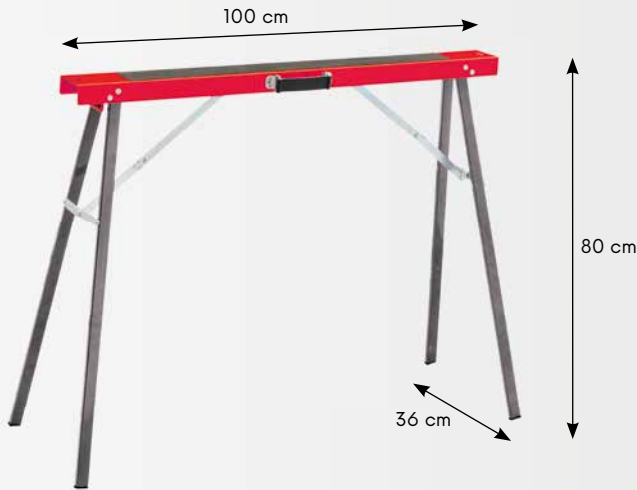

KOZA SKLADACIA

· max. nosnosť 125 kg

2x

Č.p.	špecifikácia	
37549	pár	1

KOZA PLASTOVÁ, SKLADACIA

· max. nosnosť 150 kg (300 kg v páre)

2x

Č.p.	špecifikácia	
37560	pár	1

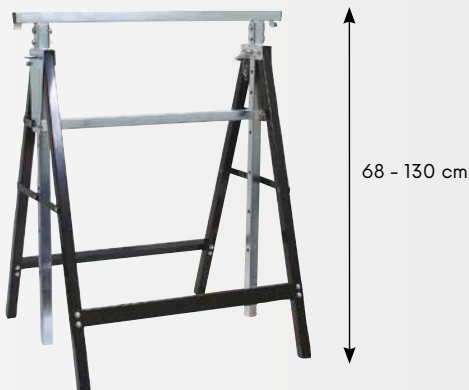

PODPERA STAVEBNÁ

Č.p.	špecifikácia	
36300	68 - 130 cm, max. 125 kg	1



KOZA LEŠENÁRSKA

Č.p.	špecifikácia	
37545	140 cm, výška 98 - 165 cm	1
37546	120 cm, výška 98 - 165 cm	1

PROFESIONÁLNE REZAČKY OBKLADOV

- Rezačky dlažby pre najnáročnejšie profesionálne použitie
- Pojazd je riešený 9 zapúzdrenými guľčikovými ložiskami SKF
- 4 sú nastaviteľné a vymedzujú vôľu pojazdu
- Odpružené stoly
- Možno kompletizovať aj pre prácu ľavou rukou
- Zabezpečené všetky náhradné diely a servis
- Rezná kolieska z chróm volfrámovej ocele

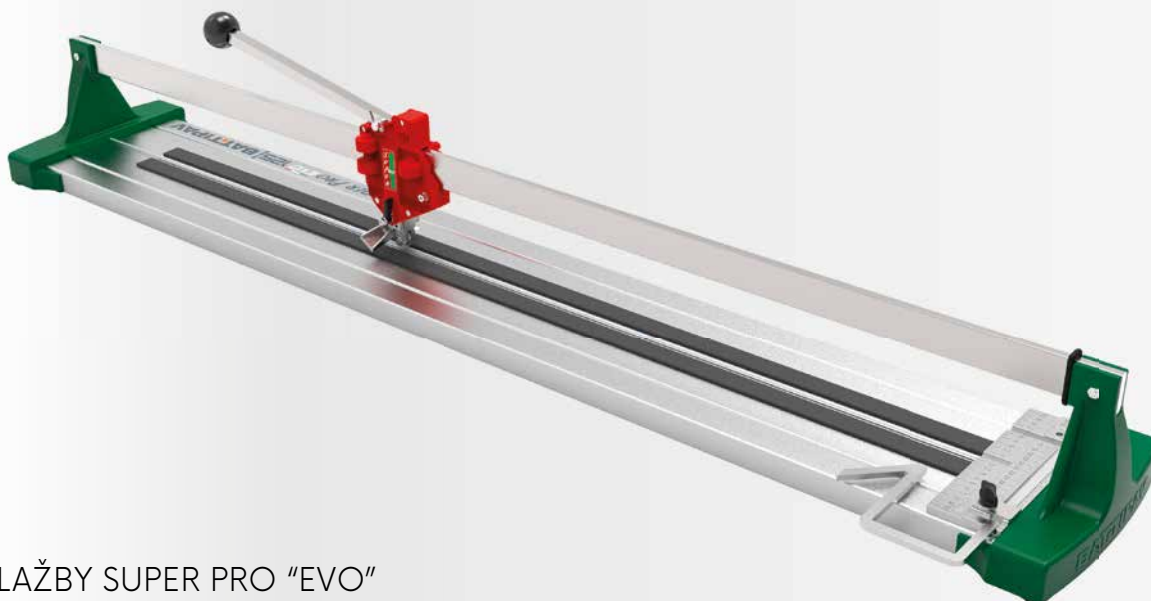

SUPER PRO



REZAČKA DLAŽBY SUPER PRO "EVO"

36195 náhr. rezné koliesko - Ø 22 mm



Č.p.	špecifikácia
36191	1250 mm



1

SUPER PRO



REZAČKA DLAŽBY SUPER PRO

36195 náhr. rezné koliesko - Ø 22 mm



Č.p.	špecifikácia
36145	SUPER PRO 450 mm
36160	SUPER PRO 600 mm
36175	SUPER PRO 750 mm
36190	SUPER PRO 900 mm



1

1

1

1



REZAČKA DLAŽBY BASIC PLUS + KUFOR

· 36261 náhr. rezné koliesko - Ø 15 mm



Č.p.	špecifikácia	
36240	400 mm	1



· ilustračné foto

PREDAJNÝ STOJAN



Č.p.	špecifikácia	
36200	predajný stojan	1
36199	predajný stojan osadený 36160, 36175, 36190	1



FESTA

REZAČKA DLAŽBY „X“

· 36138 náhr. rezné koliesko - Ø 22 mm



Č.p.	špecifikácia	
36085	600 mm	1
36087	900 mm	1
36086	1300 mm	1



FESTA

REZAČKA DLAŽBY

· 36195 náhr. rezné koliesko - Ø 22 mm



Č.p.	špecifikácia	
36080	600 mm	1
36081	750 mm	1
36082	900 mm	1

Č.p.	špecifikácia	
36076	750 mm zložená	1
36077	900 mm zložená	1

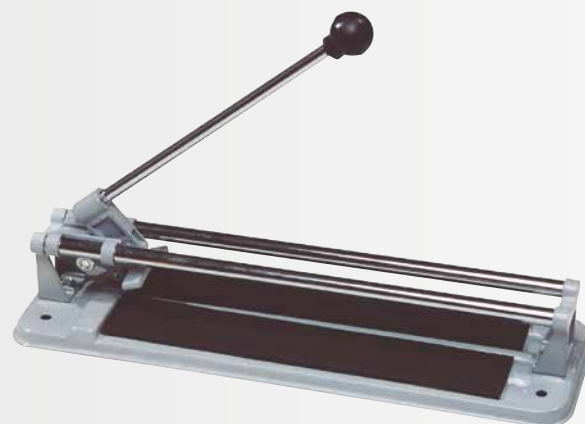
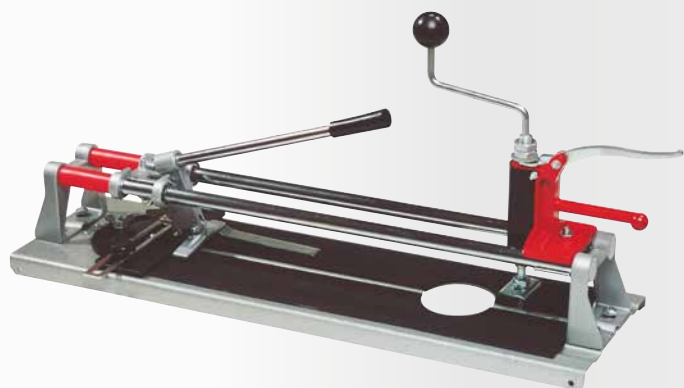

REZAČKA DLAŽBY S VYKRUŽOVÁKOM

36128 náhr. rezné koliesko - Ø 16 mm



Č.p.	špecifikácia
36014	480 mm



4

REZAČKA DLAŽBY

36126 náhr. rezné koliesko - Ø 15 mm



Č.p.	špecifikácia	
36024	300 mm	10
36034	400 mm	10
36035	600 mm	4



10

10

4



REZAČKA DLAŽBY

36136 náhr. rezné koliesko - Ø 22 mm



Č.p.	špecifikácia
36036	480 mm



1



REZAČKA DLAŽBY RUČNÁ

36136 náhr. rezné koliesko - Ø 22,2 mm



Č.p.	špecifikácia	
36046	22 mm	1



1

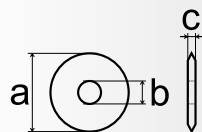

NÁHRADNÉ KOLIESKO DO REZAČIEK

Č.p.	špecifikácia	
36126	a= Ø 15 mm, b= Ø 6 mm, c= 1,5 mm	1
36128	a= Ø 16 mm, b= Ø 6 mm, c= 3 mm	1
36130	a= Ø 20 mm, b= Ø 6 mm, c= 5 mm	1
36136	a= Ø 22 mm, b= Ø 6 mm, c= 2 mm	1



1



PÍLKA PRIAMOČIARA NA OBKLADY A KERAMIKU

Č.p.	špecifikácia	
24055	Karbid - BOSCH, MAKITA	1



1



FESTA

KLIESTE NA OBKLADY

Č.p.	špecifikácia	
36057	200 mm	6



KLIESTE NA OBKLADY

Č.p.	špecifikácia	
36056		10



KLIESTE ŠTIEPACIE NA KERAMIKU

Č.p.	špecifikácia	
36059		1



KLIESTE (PAPAGÁJ)

Č.p.	špecifikácia	
36058	200 mm	6



37028



37029

VYMÝVACIE HUBY 160 X 110 X 60 MM

Č.p.	špecifikácia	
37028	hydro huba	1
37029	morská huba	1



37025



37026

VYMÝVACIE HUBY 200 X 100 X 100 MM

Č.p.	špecifikácia	
37025	jemný molitan	1
37026	morská huba	1



VANIČKA VYMÝVACIA

Č.p.	špecifikácia	
37117	sada	1
90070	nádoba 25 l	1

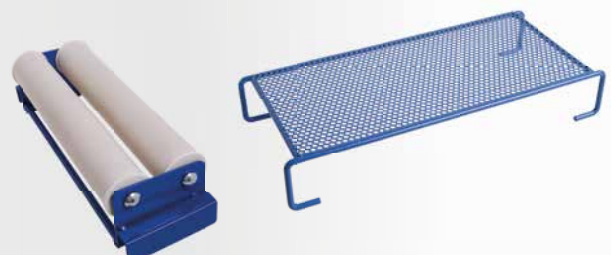

VANIČKA VYMÝVACIA - PRÍSLUŠENSTVO

Č.p.	špecifikácia	
90072	mriežka	1
90071	valčeky kovové	1





ČISTIČ ŠPÁR

Č.p.	špecifikácia
37012	



1



ČISTIČ ŠPÁR

Č.p.	špecifikácia	
37006	30 mm	20
37007	50 mm	20
37008	náhradné ostrie 30 mm	50
37009	náhradné ostrie 50 mm	50



SADA NA APLIKÁCIU A ODSTRÁNENIE SILIKÓNU

3x

Č.p.	špecifikácia
16042	



12



FESTA

APLIKÁTOR SILIKÓNU

Č.p.	špecifikácia
16056	145 mm



50



SADA STIEROK

4x

Č.p.	špecifikácia
37053	



48



STIERKA

Č.p.	špecifikácia
37054	

1



STIERKA

na škárovanie okien

Č.p.	špecifikácia
37055	



1

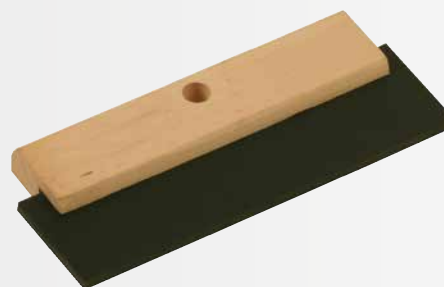

STIERKA DREVENÁ S GUMOU

Č.p.	špecifikácia
37011	180 mm
37021	280 mm

12
12

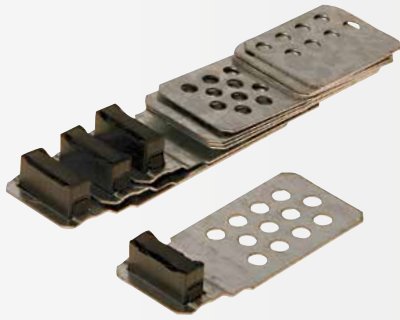

MAGNETY POD OBKLADY



Č.p.
38920

1



MAGNETY NASTAVITELNÉ
POD OBKLADY



Č.p.
38923



24

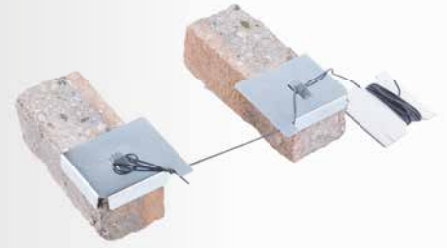

ROŽKY STAVEBNÉ - SADA

Č.p.
38919

50

NEW



FESTA

REZAČKA
VINYLU A LAMINÁTU



Č.p. špecifikácia
36140 210 mm



4



MONTÁŽNA SAĎA NA
PĽAVAJÚCE PODLAHY

24x

Č.p.
52130

1



MONTÁŽNE KLINY - PLAST

50x

Č.p.	špecifikácia	ks
37210	95 x 45 x 15 - 0 mm	50
37211	70 x 30 x 8 - 0 mm	50



VANKÚŠIK MONTÁŽNY,
ROZPÍNACÍ

· rozmery 15x17 cm
· max. výška 5 cm

Č.p.
37220

1

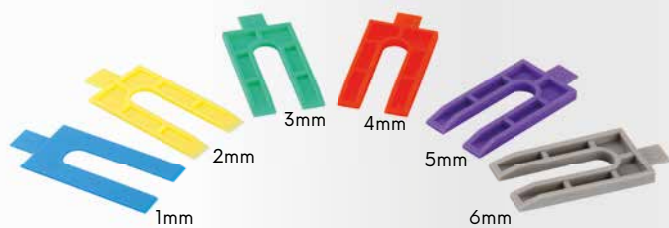

VYMEZOVACIE PODLOŽKY

30x

Č.p.	špecifikácia	ks
37212	1 - 6 mm, 5 ks od každej veľkosti	1



FESTA

MONTÁŽNE KLINIKY - DREVO



Č.p.	špecifikácia	ks
37204	55 x 20 x 0 - 6 mm	20
37203	65 x 18 x 0 - 12 mm	20
37202	80 x 25 x 3 - 10 mm	20
37201	100 x 25 x 1 - 16 mm	14
37200	150 x 25 x 1 - 25 mm	8
37205	55 x 8 x 0 - 10 mm	250

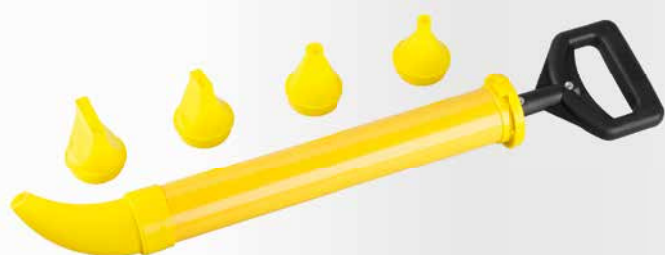

PIŠTOĽ ŠKÁROVACIA



Č.p.	špecifikácia	ks
38026	5x špička	1



VRECE ŠKÁROVACIA



Č.p.	špecifikácia	ks
38042	3x špička	1



NIVELYS KRÍŽIKY DIŠTANČNÉ

· opakovane použiteľné

100x

Č.p.	špecifikácia	ks
37195	1,0 mm	100
37196	1,5 mm	100
37197	2 mm	100
37198	3 mm	100



FESTA

KRÍŽIKY OBKLADAČSKÉ



Č.p.	špecifikácia	ks
37148	1,0 mm	200
37149	1,5 mm	200
37150	2 mm	200
37151	2,5 mm	200
37152	3 mm	150
37153	4 mm	100
37154	5 mm	75
37158	10 mm	30



FESTA

KLINIKY OBKLADAČSKÉ



Č.p.	špecifikácia	ks
37155	0 - 8 mm	30
37156	0 - 4 mm	100
37157	2,5 - 8 mm	30



FESTA

MONTÁŽNE KLINIKY - DREVO

250x



Č.p.	špecifikácia	ks
37205	55 x 8 x 0 - 10 mm	250

NEW



NIVELAČNÝ KLIP SADA

50x

Č.p.	špecifikácia
37199	1,5 mm



40



NIVELYS
DIŠTANČNÝ KLIP SO ZÁVITOM

50x

Č.p.	špecifikácia
37131	1 mm
37132	2 mm



40

NIVELYS
KLOBÚČIK NIVELAČNÝ SO ZÁVITOM

· opakovane použiteľné

50x

Č.p.
37130



15



NIVELYS
LEVELING SYSTEM **FESTA**



NIVELYS DIŠŤANČNÉ SPONY

· nivelačné klinky 37175, 37176

50x



Č.p.	špecifikácia	ks	
37170	1 mm	50	60
37171	2 mm	50	60
37172	3 mm	50	60



NIVELYS DIŠŤANČNÉ SPONY

100x



Č.p.	špecifikácia	ks	
37185	1 mm	100	1
37190	1,5 mm	100	1
37186	2 mm	100	1

Č.p.	špecifikácia	ks	
37187	3 mm	100	1
37188	4 mm	100	1
37189	5 mm	100	1

NEW

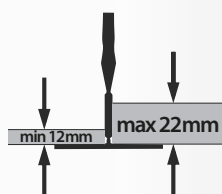

NIVELYS DIŠŤANČNÉ SPONY

100x



Č.p.	špecifikácia	
37162	1,5 mm	1



NIVELYS NIVELAČNÉ KLINKY

Č.p.	ks	
37175	50	40
37176	400	3



NIVELYS DIŠŤANČNÉ SPONY

600x



Č.p.	špecifikácia	ks	krabice	
37125	1 mm	600	38 x 28 x 19 cm	1
37126	1,5 mm	600	38 x 28 x 19 cm	1
37127	2 mm	600	38 x 28 x 19 cm	1



NIVELYS
LEVELING SYSTEM **FESTA**

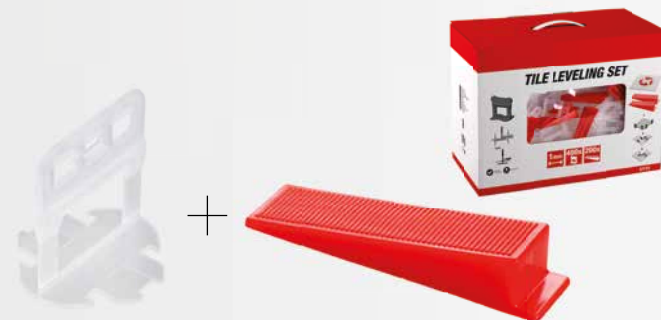

NIVELYS NIVELAČNÁ SADA

Č.p.	špecifikácia	
37173	1 mm, 400 ks + 200 ks	1
37174	1,5 mm, 400 ks + 200 ks	1



NIVELYS
KLIESTE NIVELAČNÉ

Č.p.
37177



NIVELYS
KLIESTE NIVELAČNÉ

Č.p.
37178



NEW



FESTA

DRŽIAK NA DLAŽBU
S INDIKÁTOROM PODTLAKU
drsne a štruktúrované povrchy

Č.p. 36325 Špecifikácia max. 220 kg



FESTA**PÚDER 180 G**

Č.p.	špecifikácia	
37096	modrý	10
37094	svetlo modrý	10
37097	červený	10
37095	svetlo červený	10
37098	čierny	10

**FESTA****SADA NAVÍJAČ 30 M + PÚDER 120 G**

· 6x rýchlejší mechanizmus navíjania
· Funkcie oľovníce

Č.p.
37070



6

**FESTA****SADA NAVÍJAČ 30 M + PÚDER 150 G**

· 5x rýchlejší mechanizmus navíjania

Č.p.
37065



6

**SADA NAVÍJAČ ABS 30 M + PÚDER 180 G**

Č.p.
37069



10

**NAVÍJAČ ABS 30 M**

Č.p.
37067



25

**NAVÍJAČ PLASTOVÝ 30 M**

Č.p.
37066



25

**NAVÍJAČ KOVOVÝ 30 M****ALU**

Č.p.
37068



25



FESTA

POVRÁZOK ČERVENÝ



Č.p.	špecifikácia	
38895	50 m	24
38896	100 m	24

FESTA

POVRÁZOK ŽLTÝ



Č.p.	špecifikácia	
38899	50 m	24
38900	100 m	24



FESTA

POVRÁZOK MURÁRSKY POLYETYLÉN 50 M



Č.p.	špecifikácia	
38907	červený 1,0 mm	100
38908	červený 1,7 mm	100
38909	červený 2,0 mm	100

FESTA

POVRÁZOK MURÁRSKY POLYETYLÉN 50 M



Č.p.	špecifikácia	
38904	žltý 1,0 mm	100
38905	žltý 1,7 mm	100
38906	žltý 2,0 mm	100



FESTA

POVRÁZOK MURÁRSKY POLYETYLÉN 50 M



Č.p.	špecifikácia	
38910	oranžový 1,0 mm	100
38911	oranžový 1,7 mm	100
38912	oranžový 2,0 mm	100

FESTA

POVRÁZOK MURÁRSKY POLYETYLÉN 50 M



Č.p.	špecifikácia	
38901	biely 1,0 mm	100
38902	biely 1,7 mm	100
38903	biely 2,0 mm	100

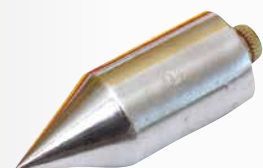

ŠNÚRA VOSKOVANÁ



Č.p.	dĺžka	Ø	
50920	50 m	1 mm	80

FESTA

OLOVNICA S POVRÁZKOM 15 M



Č.p.	špecifikácia	
38916	150 g	10
38917	300 g	6
38918	500 g	5

FESTA

OLOVNICA



Č.p.	špecifikácia	
38913	150 g	10
38914	300 g	10
38915	500 g	10

NEW



FESTA

REZAČKA POLYSTYRÉNU STRUNOVÁ

- Napätie / frekvencia: 230 V/50 Hz
 - Príkon: 160 W
 - Dĺžka rezu: 137 cm
 - Výška rezu: 30 cm
 - Krytie: IP44
 - Uhol rezu: 0° - 90°
- vybavenie: stojan, nožný spínač, držiak na lešenie, 2x Ni-Cr rezací drôt, čistiaca mosadzná kefa, náradie a spojovací materiál, plastový box s kolieskami



Č.p. Špecifikácia

35348



1

NEW



1,7 m

FESTA

NOŽNÝ SPÍNAČ
PRE REZAČKU POLYSTYRÉNU

pre 35330, 35345, 35348

Č.p. Špecifikácia

35334



1

NEW



FESTA

STOJAN
PRE REZAČKU POLYSTYRÉNU

pre 35330, 35345, 35348

Č.p. Špecifikácia

35336



1

NEW



FESTA

NÁHRADNÁ PRUŽINA
PRE REZAČKU POLYSTYRÉNU

pre 35330, 35345, 35348

Č.p. Špecifikácia

35332



1

NEW



FESTA

DRŽIAK NA LEŠENIE
PRE REZAČKU POLYSTYRÉNU

pre 35330, 35345, 35348

Č.p. Špecifikácia

35333



1

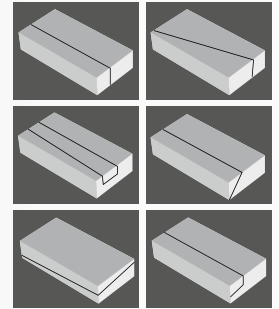
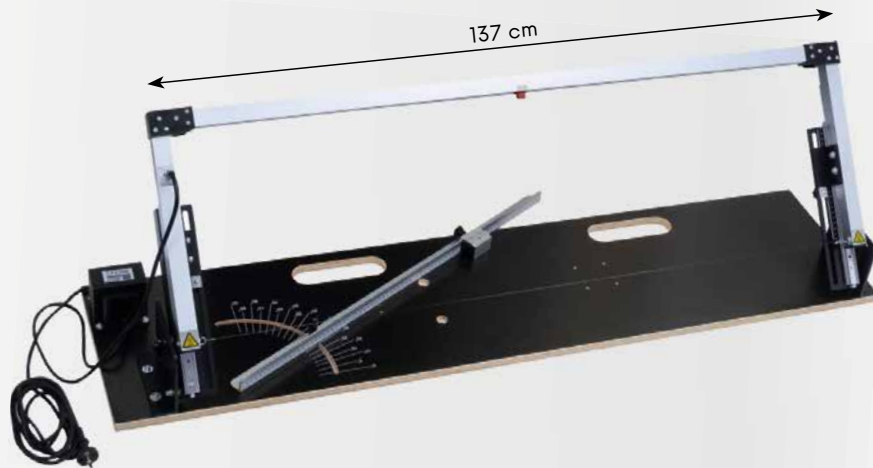

FESTA

REZAČKA POLYSTYRÉNU STRUNOVÁ

- Napätie / frekvencia: 230 V / 50 Hz
- Príkion: 160 W
- Dĺžka rezu: 137 cm
- Výška rezu: 30 cm
- Krytie: IP44
- Uhol rezu: 0° - 90°



• vybavenie: Ni-Cr rezací drôt, čistiaca mosadzná kefa, inbus



Č.p.	špecifikácia	
35345	Rezačka polystyrénu 1500 x 450 mm	1
35346	Náhradná rezná struna Ni-Cr	1
35347	náhradný zdroj	1

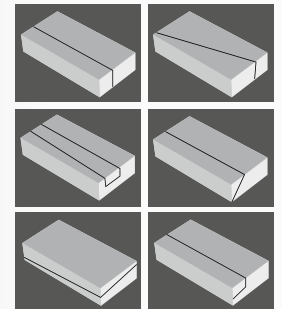
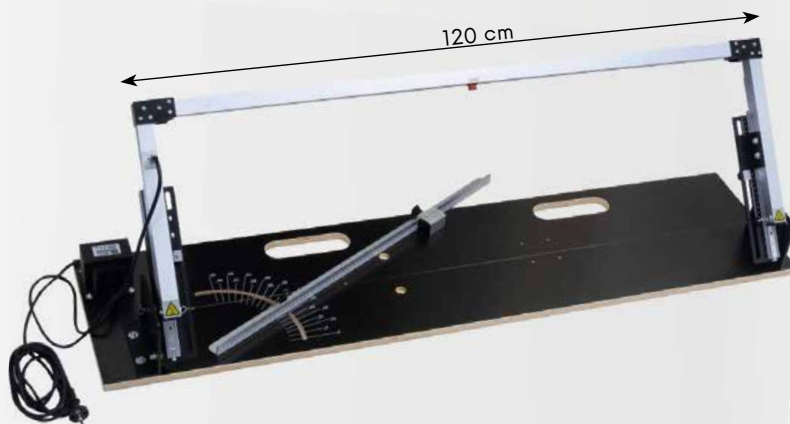

FESTA

REZAČKA POLYSTYRÉNU STRUNOVÁ

- Napätie / frekvencia: 230 V / 50 Hz
- Príkion: 160 W
- Dĺžka rezu: 120 cm
- Výška rezu: 30 cm
- Krytie: IP44
- Uhol rezu: 0° - 90°



• vybavenie: Ni-Cr rezací drôt, čistiaca mosadzná kefa, inbus



Č.p.	špecifikácia	
35330	Rezačka polystyrénu 1350 x 450 mm	1
35331	Náhradná rezná struna Ni-Cr	1
35347	náhradný zdroj	1

**FESTA****REZAČKA POLYSTYRÉNU AKUMULÁTOROVÁ**

- batéria 36 V, 1,5 Ah Li-ion
- výkon 180 W
- teplota max 350 C°
- dĺžka čepele 20 cm



· Vybavenie: 2 ks batérie, nabíjačka, čepeľ, čistiaca mosadzná kefa, inbus

Č.p. špecifikácia
35323



1

**FESTA****REZAČKA POLYSTYRÉNU ELEKTRICKÁ**

- napätie / frekvencia 230 V/50 Hz
- príkon 250 W
- teplota 50-600 C°
- dĺžka čepele 25 cm
- dĺžka privodného kábla 3 m



· Vybavenie: čistiaca mosadzná kefa, inbus, nôž 25 cm, kufo

Č.p.	špecifikácia	
35326	Elektrická rezačka polystyrénu	1
35328	Náhr. nôž do rezačky polystyrénu 14 cm	1
35329	Náhr. nôž do rezačky polystyrénu 25 cm	1

VODIACA LIŠTA PRE REZAČKU

· pre 35323, 35326

Č.p.	špecifikácia	
35327	vodiaca lišta	1
35335	Náhradný nôž - 30 cm	1



1

FESTA**REZAČKA POLYSTYRÉNU ELEKTRICKÁ**

· regulácia teploty

Č.p. špecifikácia
35325 220 W



1



FRÉZKA DO POLYSTYRÉNU



Č.p.	špecifikácia	
24727	Ø 65 mm	1
24729	Ø 68 mm	1
24728	Ø 70 mm	1



NEW

FESTA

FRÉZKA DO POLYSTYRÉNU A VATY

ALU



Č.p.	špecifikácia	
24752	Ø 65 mm	1
24753	Ø 70 mm	1



NEW

HMOŽDINKA FASÁDNÍ

100x

MADE IN EU



Č.p.	špecifikácia		Č.p.	špecifikácia	
39210	Ø 10 x 100 mm	1	39218	Ø 10 x 180 mm	1
39212	Ø 10 x 120 mm	1	39217	Ø 10 x 200 mm	1
39214	Ø 10 x 140 mm	1	39219	Ø 10 x 220 mm	1
39216	Ø 10 x 160 mm	1			

NEW

PODLOŽKA ZATEPLŔOVACIA

pre skrutky Ø 6 a 8 mm

50x

Č.p.	špecifikácia	
39208	Ø 68 mm	1

HMOŽDINKA DO IZOLÁCIE PRE SKRUTKOVACIE OBJÍMKY ZVODU

2x



Č.p.	špecifikácia	
39240	biela M10	1
39241	šedá M10	1
39242	antracit M10	1
39243	hnedá M10	1
39244	čierna M10	1

PODLOŽKA ZATEPLŔOVACIA

MOQ

Č.p.	špecifikácia	
39206	Ø 40 mm	200
39207	Ø 60 mm	100



ROH PLASTOVÝ



Č.p.	špecifikácia	
39238	3 m	25



ROH HLINÍKOVÝ



Č.p.	špecifikácia	
39245	AL 30 m x 5 cm	1



PODLOŽKA RABICOVÁ



Č.p.	špecifikácia	
42420	Ø 30 mm	1



PLETIVO RABICOVÉ



Č.p.	špecifikácia	
42312	1 m 50 bm 16 x 16 mm	1



VALČEK NIVELAČNÝ



Č.p.	priemer	výška hrotů	dĺžka	
38950	Ø 69 mm	12 mm	25 cm	10
38951	Ø 69 mm	12 mm	40 cm	8
38952	Ø 122 mm	34 mm	25 mm	10
38953	Ø 122 mm	34 mm	40 cm	8
38954	Ø 122 mm	34 mm	60 mm	4

PODOŠVY S HROTMI, PÁR



Č.p.	špecifikácia	
38970	hroty 25 mm	1
38971	hroty 30 mm	1





SADA PRE SADROKARTONÁROV

Č.p.	špecifikácia	
34300	sada 9 ks	10
34303	vanička	60



ZDVIHÁK SADROKARTÓNOVÝCH DOSIEK

- zdvih 153 - 344 cm
- maximálne zaťaženie 54 kg

Č.p.	špecifikácia	
26775		1



FESTA

NOSIČ DOSIEK

2x



Č.p.	špecifikácia	
36312		12



FESTA

NOSIČ DOSIEK

Č.p.	špecifikácia	
36308	36 x 16,5 x 7,5 cm	10

NEW



VALČEK NA NANÁŠANIE STIERKY

- rúčka 180 mm - 52630
- rúčka 250 mm - 52625
- násada 52010, 52011, 52012, 52020, 52030



Č.p.	špecifikácia	
52611	250 mm	50
52612	180 mm	10





OMIETAČKA

Zn



1

Č.p.
37114



OMIETAČKA

Zn



1

Č.p.	špecifikácia
37115	

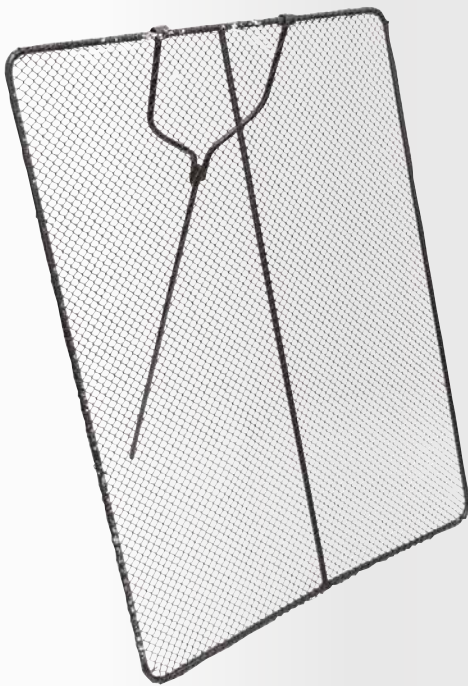

SITO PREHADZOVACIE

Č.p.	šírka	výška	oko síta	
37236	0,8 m	1 m	10 mm	1
37237	0,8 m	1 m	12 mm	1
37238	0,8 m	1 m	16 mm	1
37239	0,8 m	1 m	20 mm	1



SITO NA ŠTUK



Č.p.	šírka	výška	oko síta	
37216	50 mm	50 mm	2 mm	1
37217	50 mm	50 mm	3 mm	1
37218	50 mm	50 mm	4 mm	1



DREVENÝ OMIETNIK



Č.p.	dĺžka	hrúbka	šírka
37120	200 mm	1,7 mm	20 mm
37119	250 mm	1,7 mm	20 mm

MOQ
10

10



SIĚŤ NA LEŠENIE

Č.p.	špecifikácia		
42120	2,5 x 20 m, 80 g/ m ²	zelená	5



KRYT OTVORU MAGNETICKÝ



Č.p.	špecifikácia		
82105	25 x 25 cm	murivo	1



VLÁKNO VÝSTUŽNÉ DO BETÓNU 0,9KG

- +/- 150 g/ 50 kg cementu
- 600 - 900 g/m² betónu alebo malty



Č.p.	váha		
42115	0,9 kg		9



SKOBA MURÁRSKA KOVANÁ



Č.p.	špecifikácia		
37229	14,5 cm		10



SKOBA MURÁRSKA POZINK.



Č.p.	špecifikácia		
37231	14 cm volne		10



SKOBA MURÁRSKA KOVANÁ



Č.p.	špecifikácia		
37232	14,5 cm		5



SKOBA MURÁRSKA, SADA



Č.p.	špecifikácia		
37230	16 cm		6



KRAMĽA POZINKOVANÁ



Č.p.	špecifikácia		
37233	320 x 10 mm		100
37234	320 x 12 mm		100



KRAMĽA



Č.p.	špecifikácia		
37235	250 x 12 mm		1



PB HORÁKY

FESTA

PB HORÁK - SADA

· Ø 17, 22, 40 mm



AK 601423580004

Č.p.

špecifikácia

69918

2 kW, 1,5 m hadica



10

FESTA

PB HORÁK - SADA

· Ø 25, 35, 50 mm



AK 601423580004

Č.p.

špecifikácia

69919

19,5 kW, 1,5 m hadica



10

FESTA

PB HORÁK - SADA

· Ø 55 mm

PIEZO
START

AK 601423580004

Č.p.

špecifikácia

69904

60 kW, 850 mm, 5 m hadica



8



FESTA

SPÁJKOVACIA SÚPRAVA 3 KW



AK 601423580004

Č.p.	špecifikácia
69914	300 mm + 2 m hadica



5



FESTA

PB HORÁK



AK 601423580004

Č.p.	špecifikácia
69900	Ø 35 mm, dĺžka 300 mm, bez hadice
69901	Ø 35 mm, dĺžka 300 mm + 3 m hadica



5



FESTA

PB HORÁK



AK 601423580004

Č.p.	špecifikácia
69902	Ø 55 mm, dĺžka 550 mm, bez hadice



10



FESTA

PB HORÁK



AK 601423580004

Č.p.	špecifikácia
69903	Ø 55 mm, dĺžka 550 mm + 3 m hadica



10



FESTA

PB HORÁK



AK 601423580004

Č.p.	špecifikácia
69905	Ø 55 mm, dĺžka 850 mm, bez hadice



10

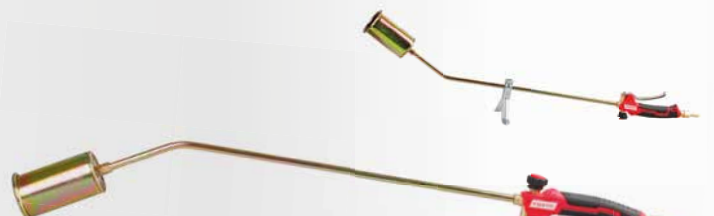

FESTA

PB HORÁK



AK 601423580004

Č.p.	špecifikácia
69906	Ø 55 mm, dĺžka 850 mm + 3 m hadica



5

**FESTA****PB HORÁK - SADA S REDUKČNÝM VENTILOM**

· redukčný ventil pre pripojenie 10 a 33 kg bomby



AK 601423580004

Č. p.	špecifikácia
69917	Ø 60 mm, dĺžka 900 mm + 3 m hadica 3 m



1

FESTA**HADICA PRE PB HORÁK**

AK 601423580004

Č. p.	špecifikácia
69910	3 m s koncovkami
69911	5 m s koncovkami
69912	10 m s koncovkami



20

12

8

**FESTA****HORÁK PLYNOVÝ NA KARTUŠI SO ZÁVITOM**

- max. teplota: 1200 °C
- výkon: 1,7 kW
- priemer horáka: Ø 20 mm



Č. p.	špecifikácia
69930	piezo

20

**FESTA****HORÁK PLYNOVÝ NA PREPICHOVACIU KARTUŠ**

- max. teplota: 1200 °C
- výkon: 1,7 kW
- priemer horáka: Ø 20 mm



Č. p.	špecifikácia
69931	piezo

12



REDUKČNÝ VENTIL PROPÁN BUTÁN



Č.p. 69923
špecifikácia W 21,8; G 3/8; 4 bar

1



REDUKČNÝ VENTIL PROPÁN BUTÁN



Č.p. 69920
špecifikácia výstupný tlak 4,0 bar
menovitý prietok 16 kg | h
pripojenia - vstup W 21,8 x 1 | 14" LH
pripojenie - výstup G3 | 8" LH

25



REDUKČNÝ VENTIL PROPÁN BUTÁN

vstupný tlak 25 bar
výstupný tlak 0,5 - 4,0 bar
menovitý prietok 16 kg | h
pripojenia - vstup W 21,8 x 1 | 14" LH
pripojenie - výstup G3 | 8" LH



Č.p. 69907
špecifikácia

1



JEDNOCESTNÝ UZATVÁRACÍ VENTIL

výstup G 3/8L, pre 2 kg PB f



Č.p. 69928
špecifikácia

1



REGULÁTOR TLAKU



Č.p. 69908
špecifikácia 30 mBar, trn
69909 30 mBar, závit G 1/4L

1

1



MISKA NA SADRU

Č.p.	špecifikácia	
37121	kónická	1



MISKA NA SADRU

Č.p.	špecifikácia	
37122	nízka	1



MISKA NA SADRU



Č.p.	špecifikácia	
33275	nízka gumová	20



VEDRO POZINKOVANÉ

Zn		
Č.p.	špecifikácia	
39000	5 l	40
39001	10 l	30
39002	12 l	20
39003	15 l	20



VEDRO MURÁRSKE



Č.p.	špecifikácia	
39005	5 l	1
39010	10 l	1
39012	12 l	1
39014	15 l s lievikom	1
39020	20 l	1
39021	20 l s lievikom	1



NÁDOBA PLAST - PRUŽNÁ



Č.p.	špecifikácia	
39192	30 l	20
39193	45 l	20



MURÁRSKA NÁDOBA KRUHOVÁ



Č.p.	špecifikácia	
39045	45 l Ø 54 x 27 cm	1
39065	60 l Ø 60 x 35 cm	1
39090	90 l Ø 66 x 35 cm	1



MURÁRSKA NÁDOBA OBDĽŽNIKOVÁ



Č.p.	špecifikácia	
39145	45 l 71 x 40 x 21 cm	1
39165	65 l 71 x 40 x 30 cm	1
39190	85 l 77 x 48 x 30 cm	1

KLDKA MURÁRSKA Z 500



Č.p.	špecifikácia	
26780	0,5 t A s hákom	1
26781	0,5 t B s okom	1
26782	0,5 t C s hákom a chráničom	1
26783	0,5 t D s okom a chráničom	1





FÓLIE ZMRŠŤOVACIE



Č.p.	šírka	dĺžka	hrúbka	farba	ks
38095	500 mm	600 m	8 µm	číra	1
38097	100 mm	150 m	20 µm	číra	1
38096	500 mm	200 m	23 µm	čierna	1

PE VRECI NA SUŤ
TRANSPARENTNÉ



Č.p.	šírka	dĺžka	hrúbka	ks
39194	500 mm	1100 mm	0,16 mm	100 1
39196	600 mm	1200 mm	0,16 mm	110 1
39198	700 mm	1100 mm	0,16 mm	120 1
39200	500 mm	1100 mm	0,20 mm	100 1
39202	600 mm	1200 mm	0,20 mm	110 1
39204	700 mm	1100 mm	0,20 mm	120 1



PE VRECI NA SUŤ
ČIERNE



Č.p.	šírka	dĺžka	hrúbka	ks
39195	500 mm	1100 mm	0,16 mm	100 1
39197	600 mm	1200 mm	0,16 mm	110 1
39199	700 mm	1100 mm	0,16 mm	120 1
39201	500 mm	1100 mm	0,20 mm	100 1
39203	600 mm	1200 mm	0,20 mm	110 1
39205	700 mm	1100 mm	0,20 mm	120 1

VRECI NA ODPAD



Č.p.	šírka	dĺžka	hrúbka	ks
38060	700 mm	1100 mm	0,08 mm	10 1
38063	700 mm	1100 mm	0,10 mm	3 1
38065	700 mm	1100 mm	0,20 mm	3 1

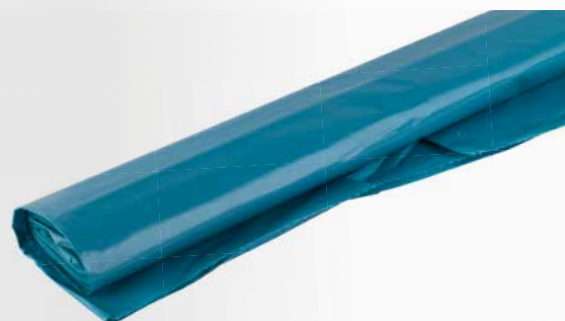

VRECI NA ODPAD



Č.p.	šírka	dĺžka	hrúbka	ks
38050	500 mm	600 mm	0,04 mm	25 1
38052	600 mm	800 mm	0,04 mm	25 1
38054	700 mm	1100 mm	0,04 mm	25 1

PE VRECI NA ODPAD



Č.p.	šírka	dĺžka	hrúbka	ks
38055	1200 mm	1000 mm	0,08 mm	5



ÚVÄZOK FIXAČNÝ



Č.p.	špecifikácia	ks
42365	1,25 100 mm	1
42366	1,25 125 mm	1
42367	1,25 140 mm	1
42368	1,25 160 mm	1

VIAZAČ VRIEC

Č.p.	špecifikácia	ks
50052		12
50050		1

VIAZAČ VRIEC - RÁDLOVAČKA

Č.p.	špecifikácia	ks
50051		2



FÓLIA VÝSTRAŽNÁ - EL. VEDENIE

Č.p.	šírka	dĺžka	
38955	22 cm	20 m	1
38956	22 cm	50 m	1



FOLIA VÝSTRAŽNÁ - VODA

Č.p.	šírka	dĺžka	
38957	22 cm	20 m	1
38958	22 cm	50 m	1



FOLIA VÝSTRAŽNÁ - PLYN

Č.p.	šírka	dĺžka	
38959	22 cm	20 m	1
38960	22 cm	50 m	1



PÁSKA ALARMUJÚCA

Č.p.	špecifikácia	dĺžka	
38944	ZÁKAZ VSTUPU, SK	80 mm 250 m	8
38945	VSTUP ZAKÁZANÝ, CZ	80 mm 250 m	8



PÁSKA ALARMUJÚCA

Č.p.	dĺžka	
38948	80 mm 250 m	8

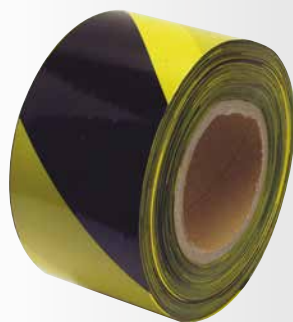

Č.p.	dĺžka	
38946	80 mm 250 m	8



PÁSKA ALARMUJÚCA - SAMOLEPIACA

Č.p.	dĺžka	špecifikácia	
38947	48 mm 33 m	pravá	48
38961	48 mm 33 m	ľavá	48



TRASOVACIA PÁSKA

Č.p.	šírka	dĺžka	hrúbka materiálu	
38949	50 mm	50 m	0,15 mm	36

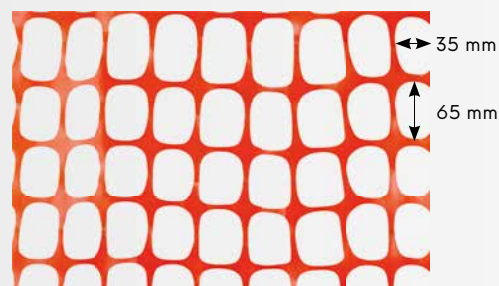

BEZPEČNOSTNÁ SIeŤ



Č.p.	špecifikácia	
42190	1,2 x 50 m HDPE 140g/m ²	1



PÁSKY PVC

5x

Č.p.	šírka	dĺžka	hrúbka materiálu	
38931	19 mm	5 m	0,13 mm	100



PÁSKA PVC - ČIERNA

Č.p.	šírka	dĺžka	hrúbka materiálu	
38932	19 mm	10 m	0,13 mm	10



PÁSKA PVC

Č.p.	šírka	dĺžka	hrúbka materiálu	
38925	19 mm	10 m	0,13 mm	10



PÁSKA PVC - ČIERNA

Č.p.	šírka	dĺžka	hrúbka materiálu	
38968	19 mm	10 m	0,19 mm	10

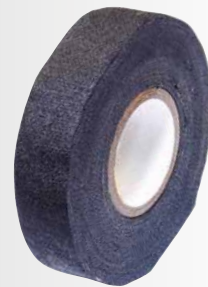

PÁSKA TEXTIL ČIERNA

Č.p.	šírka	dĺžka	
38927	19 mm	10 m	10



PÁSKA TEXTILNÁ, KOBERCOVÁ

Č.p.	šírka	dĺžka	
38980	48 mm	10 m	24
38981	48 mm	20 m	24



PÁSKA LEPIACA OBOJSTRANNÁ S VÝSTUŽOU

Č.p.	šírka	dĺžka	
38924	50 mm	10 m	1
38964	50 mm	25 m	1



PÁSKA LEPIACA OBOJSTRANNÁ, POLYPROPYLÉN

Č.p.	šírka	dĺžka	
38929	50 mm	10 m	1
38966	50 mm	25 m	1



PÁSKA LEPIACA OBOJSTRANNÁ MONTÁŽNA

Č.p.	šírka	dĺžka	
38990	19 mm	5 m	48
38991	25 mm	5 m	36



PÁSKA PROFESIONÁLNA ZOSILNENÁ, VODEODOLNÁ



Č.p.	šírka	dĺžka	
38995	48 mm	25 m	24



PÁSKA TEXTILNÁ, VODEODOLNÁ

Č.p.	šírka	dĺžka	
38965	30 mm	10 m	1
38928	50 mm	10 m	72
38934	50 mm	45 m	24



PÁSKA DUCT TAPE, VODEODOLNÁ



Č.p.	šírka	dĺžka	
37275	48 mm	50 m	24



PÁSKA FASÁDNA NA OMIETKU



Č.p.	šírka	dĺžka	
37271	38 mm	20 m	24
37270	48 mm	20 m	24
37272	48 mm	50 m	24



PÁSKA PE, VONKAJŠIA OCHRANA NA OKNÁ

po dobu 30 dní



Č.p.	šírka	dĺžka	
37273	48 mm	50 m	24



PÁSKA PROFI PAPIEROVÁ MASKOVACIA



Č.p.	šírka	dĺžka	
37263	38 mm	50 m	24
37264	48 mm	50 m	24



PÁSKA PVC MASKOVACIA



Č.p.	šírka	dĺžka	
37266	30 mm	33 m	60
37267	38 mm	33 m	48
37268	50 mm	33 m	36

PÁSKA PAPIEROVÁ MASKOVACIA



Č.p.	šírka	dĺžka	
37255	19 mm	50 m	12
37256	25 mm	50 m	12
37257	30 mm	50 m	7
37258	38 mm	50 m	6
37259	50 mm	50 m	6



PÁSKA BALIACA PVC



Č.p.	šírka	dĺžka	
38942	50 mm	50 m	72



PÁSKA POKOVOVANÁ



Č.p.	šírka	dĺžka	
38972	50 mm	50 m	1
38973	50 mm	100 m	1



FÓLIA HLINÍKOVÁ SAMOLEPIACA



Č.p.	šírka	dĺžka	
38963	48 mm	10 m	1
38943	48 mm	45 m	24



PÁSKA PROTIŠMYKOVÁ

Č.p.	šírka	dĺžka	hrúbka	
37280	25 mm	15 m	0,8 mm	72
37281	50 mm	15m	0,8 mm	36



PÁSKA SAMOVULKANIZAČNÁ

Č.p.	šírka	dĺžka	
38930	19 mm	5 m	100



PÁSKA SADROKARTONÁRSKA SAMOLEPIACA



Č.p.	šírka	dĺžka	
38935	50 mm	20 m	60
38937	50 mm	45 m	36
38939	50 mm	90 m	24
38940	50 mm	153 m	24



PÁSKA SKLOVLÁKNOVÁ



Č.p.	šírka	dĺžka	
38941	50 mm	25 m	40



PÁSKA INŠTALATÉRSKA TEFLONOVÁ



Č.p.	šírka	dĺžka	hrúbka materiálu	
38969	19 mm	15 m	0,2 mm	10



PÁSKA INŠTALATÉRSKÁ TEFLONOVÁ



Č.p.	šírka	dĺžka	hrúbka materiálu	
38933	12 mm	10 m	0,075 mm	10



NIŤ TEFLONOVÁ

· na vodu. a plyn. inštalácie



Č.p.	šírka	dĺžka	
38926	2 mm	150 m	20



ODVÍJAČ PÁSKY

Č.p.	
38985	1



VIAZACIA PÁSKA, SUCHÝ ZIPS

Č.p.	špecifikácia	
45471	12 mm x 5 m	1



PÁSKA NA SUCHÝ ZIPS, 3 KS



Č.p.	šírka	dĺžka	
37295	20 mm	150 mm	1
37296	20 mm	200 mm	1
37297	20 mm	250 mm	1

NEW



- 3 polohy prepínania spätného odskoku



- otočná hlava o 360 °

- nárazuvzdorná rukoväť nylon + sklovlákno



- prepínanie dávkovanie 9:1 / 18:1

**FESTA**

PIŠTOĽ VYTLÁČACIA S PREPÍNAČOM SPÄTNÉHO ODSKOKU A DÁVKOVANIE

Č.p. špecifikácia

38027



1

NEW



- prepínač spätného odskoku

FESTA

PIŠTOĽ VYTLÁČACIA S PREPÍNAČOM SPÄTNÉHO ODSKOKU

Č.p. špecifikácia

38028



1



FESTA

PIŠTOĽ VYTLÁČACIA ZOSILNENÁ

Č.p.	špecifikácia	
38013		12



FESTA

PIŠTOĽ VYTLÁČACIA

Č.p.	špecifikácia	
38001		24



FESTA

PIŠTOĽ VYTLÁČACIA

Č.p.	špecifikácia	
38012		6



FESTA

PIŠTOĽ VYTLÁČACIA

Č.p.	špecifikácia	
38024		1



PIŠTOĽ VYTLÁČACIA SO SPÄTNÝM ODSKOKOM

Č.p.	špecifikácia	
38010	6ti hran	24



PIŠTOĽ VYTLÁČACIA

Č.p.	špecifikácia	
38025		24



FESTA

PIŠTOĽ VYTLÁČACIA NA CHEMICKÉ KOTVY 380 ML

Č.p.	špecifikácia	
38020		12



PIŠTOĽ VYTLÁČACIA - KROKOVÁ

Č.p.	špecifikácia	
38006		12



PIŠTOĽ VYTLÁČACIA

Č.p.	špecifikácia	
38002	6ti hran	24



PIŠTOĽ VYTLÁČACIA - PLASTOVÁ

Č.p.	špecifikácia	
38003	6ti hran	24



PIŠTOĽ VYTLÁČACIA

Č.p.	špecifikácia	
38007		24



PIŠTOĽ VYTLÁČACIA - POLOUZATVORENÁ

Č.p.	špecifikácia	
38008		24



PIŠTOĽ VYTLÁČACIA OZUBENÁ

Č.p.	špecifikácia	
38009		24

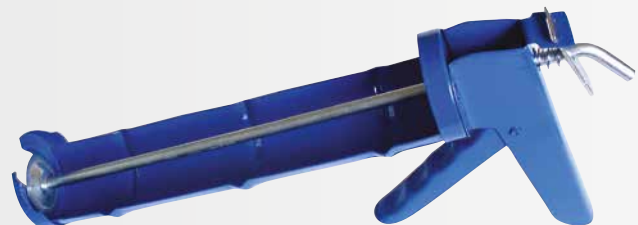

PIŠTOĽ VYTLÁČACIA

Č.p.	špecifikácia	
38000		24

**FESTA**

PIŠTOĽ VYTLÁČACIA

ALU	Č.p.	špecifikácia	
	38005	310 ml	20
	38014	špička 3 ks	100

**FESTA**

PIŠTOĽ VYTLÁČACIA

ALU	Č.p.	špecifikácia	
	38004	600 ml	12
	38014	špička 3 ks	100



FESTA

PIŠTOĽ NA PU PENY S TEFLÓNOVÝM POVRCHOM

TEFLON

Č.p. špecifikácia

38018



20



FESTA

PIŠTOĽ NA PU PENY S TEFLÓNOVÝM POVRCHOM

TEFLON

Č.p. špecifikácia

38017



20



FESTA

PIŠTOĽ NA PU PENY

TEFLON

Č.p. špecifikácia

38016



20



FESTA

PIŠTOĽ NA PU PENY

TEFLON

Č.p. špecifikácia

38015



20



PIŠTOĽ NA PU PENY

Č.p. špecifikácia

38031



20



FESTA

PIŠTOĽ NA PU PENY ABS

Č.p. špecifikácia

38022

ABS



20



PIŠTOĽ NA PU PENY

Č.p. špecifikácia

38021



24



TRYSKA NÁHRADNÁ NA PIŠTOĽ

pre pištole 38015, 38016, 38017, 38018

TEFLON

Č.p. špecifikácia
38030



5

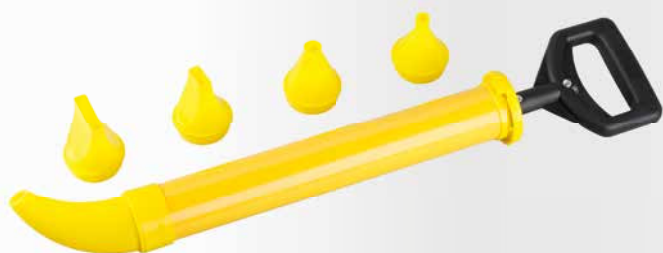

PIŠTOĽE ŠKÁROVACIA

objem 1,5 l



Č.p. špecifikácia
38026 5x špička



25

VRECE ŠKÁROVACIA



Č.p. špecifikácia
38042 3x špička



6



FESTA

PIŠTOĽ TEPOVZDUŠNÁ S REGULÁCIOU TEPLoty A PRÚDU VZDUCHU

digitalný display

FESTA

PIŠTOĽ TEPOVZDUŠNÁ S REGULÁCIOU TEPLoty

napätie / frekvencia	230V / 50Hz
príkon	2000W
poloha spínača	0 - I (350°C) - II (600°C)
príslušenstvo	nerezové nadstavce - 4 ks

napätie / frekvencia	230V / 50Hz
príkon	2000W
poloha spínača	0 - I (50°C) - II (50 - 600°C)
prúd vzduchu	250 - 500 l/min.
príslušenstvo	nerezové nadstavce - 4 ks



Č.p. špecifikácia
35320 2000 W



1



Č.p. špecifikácia
35322 2000 W



1



TAVNÉ PISTOLE

FESTA

PIŠTOĽ TAVNÁ - BEZDRÔTOVÁ

· Ø tavné tyčinky 11,2 mm



Č.p.	špecifikácia
89975	80 W 230 V



PIŠTOĽE TAVNÁ

· Ø tavné tyčinky 7,2 mm



Č.p.	špecifikácia
89970	15 W 230 V



PIŠTOĽE TAVNÁ

· Ø tavné tyčinky 11,2 mm



Č.p.	špecifikácia
89973	60 W 230 V



TYČINKY DO TAVNEJ PIŠTOĽE

Č.p.	Ø tyčinky	dĺžka	ks	kg
89980	7,2 mm	100 mm	12 ks	100
89988	7,2 mm	100 mm	1 kg	25



TYČINKY DO TAVNEJ PIŠTOĽE

Č.p.	Ø tyčinky	dĺžka	ks	kg
89985	11,2 mm	200 mm	10 ks	50
89987	11,2 mm	200 mm	1 kg	25



TYČINKY DO TAVNEJ PIŠTOĽE

Č.p.	Ø tyčinky	dĺžka	ks	kg
89989	7,2 mm	100 mm	12 ks	100
89990	11,2 mm	200 mm	10 ks	50



ŠTETCE A VALČEKY



ŠTETEC PLOCHÝ NATUR

Č.p.	šírka	hrúbka	dĺžka	
52212	20 mm	15 mm	40 mm	12
52213	30 mm	15 mm	45 mm	12
52214	40 mm	15 mm	45 mm	12
52215	50 mm	15 mm	50 mm	12
52216	60 mm	15 mm	60 mm	12
52217	70 mm	15 mm	65 mm	12
52218	80 mm	15 mm	65 mm	12
52220	100 mm	15 mm	70 mm	12



ŠTETEC PLOCHÝ

Č.p.	šírka	hrúbka	dĺžka	
52202	20 mm	12,5 mm	38 mm	12
52203	30 mm	13 mm	38 mm	12
52204	40 mm	14 mm	44 mm	12
52205	50 mm	16 mm	44 mm	12
52206	60 mm	17 mm	52 mm	12
52208	80 mm	17 mm	52 mm	12
52207	100 mm	18 mm	52 mm	12



ŠTETEC ZÁROHOVÝ

Č.p.	šírka	hrúbka	dĺžka	
52283	25 mm	10 mm	44 mm	12
52284	38 mm	10 mm	44 mm	12
52285	50 mm	10 mm	44 mm	12
52286	62 mm	10 mm	50 mm	12
52288	76 mm	10 mm	50 mm	12



SADA ŠTETCOV - PLASTOVÁ RUKOVÄŤ

Č.p.	špecifikácia	
52070	20, 30, 50 mm	50

3x



SADA ŠTETCOV - PLASTOVÁ RUKOVÄŤ

5x



Č.p.	špecifikácia
52071	15 mm, 25 mm, 40 mm, 60 mm, 80 mm

50



ŠKRABKA NA FARBY A LAKY

Č.p.
37005

12



MALIARSKA ŠTETKA PROFÍ



Č.p.	špecifikácia
52075	Ø 90 mm

10



MALIARSKA ŠTETKA PROFÍ



Č.p.	šírka	dĺžka
52076	170 mm	80 mm

10



MALIARSKA ŠTETKA

Č.p.	špecifikácia	dĺžka
52077	Ø 105 mm	70 mm

12



MALIARSKA ŠTETKA

Č.p.	šírka	dĺžka
52078	170 mm	70 mm

12

TABUĽKA POUŽITIA MALIARSKYCH VALČEKOV		FARBY A LAKY												
MATERIÁL	VÝŠKA VLASU MM	DISPERZNÉ	ANTIKÓROZNE	ŽVICOVÉ	OLEJOVÉ	VODOU RIED.	POLYESTEROVÉ	POJIVOVÉ	LAZURY	LATEXOVÉ	EPOXYDOVÉ	2-KOMPO- NENTNÉ	HUSTÉ	AKRYLOVÉ
PES	20	•						•		•			•	
PES	20	•	•			•		•		•				•
PAC	18	•						•		•				
PAC	12, 13	•								•				
PAD	18, 21	•								•				
PAD	13	•	•							•				
BARÁNOK	23	•								•				
NYLON	13		•	•	•	•	•			•	•	•		
VELOUR	4		•	•			•			•	•		•	
MICROFIBRE	10					•			•	•				
MOLITAN				•		•								•



PENETRAČNÁ SÚPRAVA

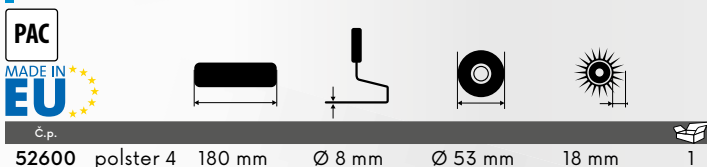

MALIARSKA SÚPRAVA - VESTAN

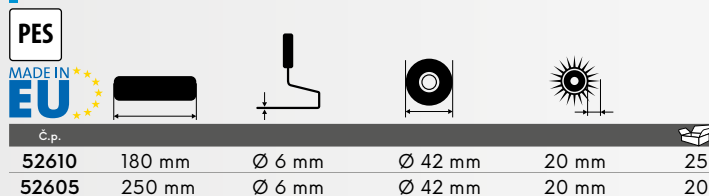

LAKOVACIA SÚPRAVA

- 1x valček PAD 13mm / 10 cm
- 1x valček PAC 12mm / 10 cm
- 1x valček PES 11mm / 10 cm
- držiak
- miska

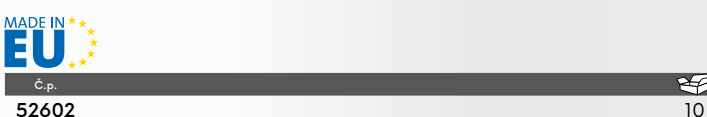

ROHOVÝ VALČEK POLYAKRYL

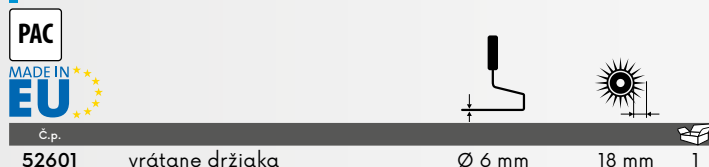



VALČEK POLYAKRYL

PAC MADE IN EU					
Č.p.					
52331	100 mm	Ø 6 mm	Ø 17 mm	12 mm	50
52334	250 mm	Ø 8 mm	Ø 48 mm	12 mm	10



VALČEK POLYAKRYL

PAC MADE IN EU					
Č.p.					
52391	polster 5 250 mm	Ø 8 mm	Ø 54 mm	18 mm	10



VALČEK POLYAKRYL

PAC MADE IN EU					
Č.p.					
52328	polster 5 250 mm	Ø 8 mm	Ø 54 mm	18 mm	10
52456	polster 7 250 mm	Ø 8 mm	Ø 67 mm	18 mm	10



VALČEK POLYAMID

PAD MADE IN EU					
Č.p.					
52428	polster 7 250 mm	Ø 8 mm	Ø 67 mm	18 mm	10



VALČEK POLYESTER

PES MADE IN EU					
Č.p.					
52315	polster 5 180 mm	Ø 8 mm	Ø 54 mm	20 mm	10



VALČEK LAZÚROVACÍ - NYLON

PAD MADE IN EU					
Č.p.					
52421	100 mm	Ø 6 mm	Ø 17 mm	13 mm	50
52424	250 mm	Ø 8 mm	Ø 48 mm	13 mm	10



VALČEK POLYESTER

PES MADE IN EU					
Č.p.					
52305	180 mm	Ø 6 mm	Ø 42 mm	20 mm	10
52306	250 mm	Ø 6 mm	Ø 42 mm	20 mm	10



VALČEK LAKOVACÍ MOLITAN

MADE IN EU					
Č.p.					
52471	rovný 100 mm	Ø 6 mm	Ø 35 mm	50	

NEW



FESTA®

TELESKOPICKÁ TYČ

- závit pre 31610, 34203

Č.p.	špecifikácia	
52011	88 - 140 cm	1



TELESKOPICKÁ TYČ

ALU

Č.p.	dĺžka		
52010	120 cm	ALU	50
52012	240 cm	ALU	25

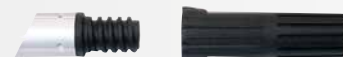

TELESKOPICKÁ TYČ

Č.p.	dĺžka		
52020	300 cm	ocel'	10

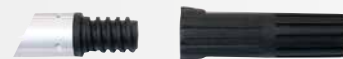

TELESKOPICKÁ TYČ

Č.p.	dĺžka		
52030	240 cm	fiberglass	6

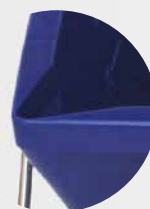
MISKA
MADE IN EU

Č.p.	špecifikácia	
52662	150 x 270 mm 100 mm	1
52666	260 x 290 mm 180 mm	1
52671	330 x 340 mm 250 mm	1

VEDRO NA FARBU
MADE IN EU

Č.p.	objem	
52694	8 l	25
52695	12 l	20

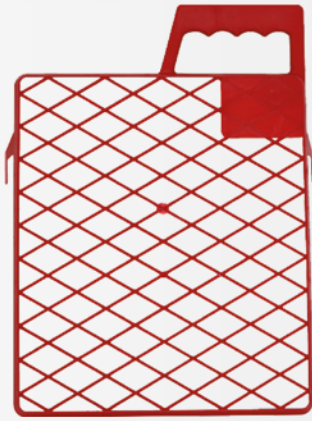

MRIEŽKA



Č.p.	šírka	výška	
52652	230 mm	250 mm	100
52656	270 mm	290 mm	100



DRŽIAK



Č.p.	špecifikácia	
52640	5 cm Ø 6 mm	100
52645	8,5 cm Ø 6 mm x 27 mm	100

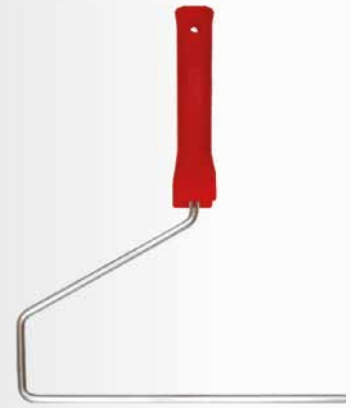

DRŽIAK



Č.p.	špecifikácia	
52630	18 cm Ø 6 mm	100
52635	25 cm Ø 6 mm	100
52620	18 cm Ø 8 mm	50
52625	25 cm Ø 8 mm	50



PÁSKA KRYCIA SAMOLEPIACA S FÓLIOU

Č.p.	šírka	dĺžka	
37243	55 cm	30 m	60
37244	110 cm	30 m	30
37245	140 cm	30 m	30
37246	180 cm	15 m	30
37290	210 cm	20 m	30
37247	240 cm	15 m	30
37291	270 cm	16 m	30



OCHRANNÁ KOMBINÉZA S KAPUCNOU

Č.p.	špecifikácia	
50585	velikost M	1
50586	velikost L	1
50587	velikost XL	1
50588	velikost XXL	1



FÓLIA DO DVERÍ SO ZIPSOM

Č.p.	špecifikácia	
37248	1,2 x 2,2 m páska 100 µm 45 mm x 25 m	25



UNIVERZÁLNA KRYCIA FÓLIA

Č.p.	objem	hrúbka materiálu	
37250	4 x 5 m	0,007 mm	100
37251	4 x 12,5 m	0,007 mm	50
37252	2 x 50 m	0,007 role	20



UNIVERZÁLNA KRYCIA FÓLIA

Č.p.	špecifikácia	hrúbka materiálu	
37253	4 x 5 m	0,03 mm	100



LEPENKA VLNITÁ



Č.p.	šírka	dĺžka	
54008	1 m	10 m	1



EKONOMIK ** STANDARD *** PROFI ****

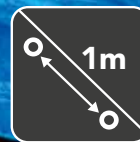

- Zdvojené zvarené lemy s polypropylénovou šnúrou
- Strieborná vrstva pre zvýšený odraz slnečného žiarenia
- ALU oká po 1 m



NEPREMOKAVÁ PLACHTA EKONOMIK

· modrá



Č.p.	špecifikácia	
25369	2 x 2 m	50
25370	2 x 3 m	20
25371	3 x 4 m	10
25372	3 x 5 m	10
25373	4 x 5 m	10

Č.p.	špecifikácia	
25374	4 x 6 m	5
25376	5 x 8 m	5
25378	6 x 10 m	2
25379	8 x 12 m	2
25380	10 x 15 m	2



NEPREMOKAVÁ PLACHTA STANDARD

· modro-strieborná



Č.p.	špecifikácia		Č.p.	špecifikácia	
25155	2 x 2 m	50	25025	5 x 5 m	10
25006	2 x 3 m	50	25030	5 x 6 m	10
25009	3 x 3 m	35	25040	5 x 8 m	5
25012	3 x 4 m	20	25048	6 x 8 m	5
25015	3 x 5 m	10	25060	6 x 10 m	5
25016	4 x 4 m	10	25096	8 x 12 m	2
25020	4 x 5 m	10	25150	10 x 15 m	2
25024	4 x 6 m	10	25153	15 x 20 m	1



NEPREMOKAVÁ PLACHTA STANDARD

· zelená



Č.p.	špecifikácia	
25179	2 x 2 m	50
25180	2 x 3 m	50
25195	2 x 8 m	20
25181	3 x 4 m	20
25182	3 x 5 m	10
25183	4 x 5 m	10

Č.p.	špecifikácia	
25184	4 x 6 m	10
25186	5 x 8 m	5
25188	6 x 10 m	5
25189	8 x 12 m	2
25190	10 x 15 m	2



PE NEPREMOKAVÁ PLACHTA PROFI

· modro-strieborná



Č.p.	špecifikácia		Č.p.	špecifikácia	
25206	2 x 3 m	25	25240	5 x 8 m	4
25212	3 x 4 m	10	25248	6 x 8 m	3
25215	3 x 5 m	8	25260	6 x 10 m	3
25220	4 x 5 m	8	25296	8 x 12 m	2
25224	4 x 6 m	8	25350	10 x 15 m	1
25230	5 x 6 m	8			



PE NEPREMOKAVÁ PLACHTA PROFI

· zeleno-zelená

200 g/m²

Č.p.	špecifikácia		Č.p.	špecifikácia	
25160	2 x 3 m	15	25164	4 x 6 m	3
25171	2 x 8 m	1	25167	6 x 8 m	2
25162	3 x 5 m	5	25169	8 x 12 m	1
25163	4 x 5 m	4	25170	10 x 15 m	1

PE NEPREMOKAVÁ PLACHTA OKRÚHLA

· modro-strieborná

120 g/m²

Č.p.	špecifikácia		Č.p.	špecifikácia	
25003	Ø 3,6 m	15	25004	Ø 4,5 m	5
25005	Ø 5,5 m	4	25002	Ø 6,5 m	3



NAPINÁK PLACHIET

4x

Č.p.	špecifikácia	
25400	20 cm	1



APLIKÁTOR ÔK DO PLACHIET

Č.p.	špecifikácia	
25410	aplikátor ôk + 25 ôk 1	1



ÔKÁ DO PE PLACHIET

10x

Č.p.	špecifikácia	
25001		1



KARABÍNY, REŤAZE A OCEĽOVÉ LANÁ



NAPÍNACIA SKRUTKA

DIN 1480 Zn

Č.p.	špecifikácia	
50100	5 x 70 mm	10
50101	6 x 90 mm	10
50102	8 x 125 mm	10
50103	10 x 150 mm	10

Č.p.	špecifikácia	
50104	12 x 200 mm	10
50106	16 x 230 mm	10
50108	20 x 220 mm	10



KARABÍNA

DIN 5299 C Zn

Č.p.	špecifikácia	
51204	4 mm	10
51205	5 mm	10
51206	6 mm	10
51207	7 mm	10
51208	8 mm	10

Č.p.	špecifikácia	
51209	9 mm	10
51210	10 mm	10
51211	11 mm	10
51212	12 mm	10



ČLÁNOK RAPID

Zn

Č.p.	špecifikácia	
51241	4 mm	10
51242	5 mm	10
51243	6 mm	10
51244	7 mm	10

Č.p.	špecifikácia	
51245	8 mm	10
51246	10 mm	10
51247	12 mm	10



S HÁK

Zn

Č.p.	špecifikácia	
51271	3 mm	10
51272	4 mm	10
51273	5 mm	10
51274	6 mm	10

Č.p.	špecifikácia	
51275	7 mm	10
51276	8 mm	10
51278	10 mm	10



MATICA OČKOVÁ

DIN 5820 Zn

Č.p.	špecifikácia	
51320	6 mm	10
51321	8 mm	10
51322	10 mm	10
51323	12 mm	10

Č.p.	špecifikácia	
51324	14 mm	10
51325	16 mm	10
51327	20 mm	10



SKRUTKA OČKOVÁ

DIN 5820 Zn

Č.p.	špecifikácia	
51300	6 mm	10
51301	8 mm	10
51302	10 mm	10
51303	12 mm	10
51304	14 mm	10

Č.p.	špecifikácia	
51305	16 mm	10
51306	18 mm	10
51307	20 mm	10
51308	22 mm	10

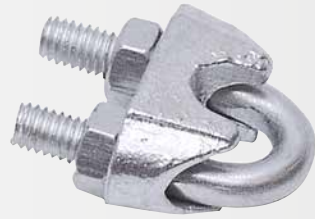

SVORKA LANOVÁ

Zn

Č.p.	špecifikácia	
51280	3 mm	10
51281	5 mm	10
51282	6 mm	10
51283	8 mm	10

Č.p.	špecifikácia	
51284	10 mm	10
51286	12 mm	10
51287	14 mm	10
51288	16 mm	10



KARABÍNA OTOČNÁ

Zn

Č.p.	špecifikácia	
51220	53 mm	10
51221	67 mm	10
51222	76 mm	10



LANOVÁ SVORKA OTOČNÁ

Zn

Č.p.	špecifikácia	
51225	3,8 mm	10
51226	4,5 mm	10
51227	6,0 mm	10



REŤAZ KRÁTKE OKO

DIN 5685 A Zn

Č.p.	veľkosť oka	dĺžka	
51402	2 x 10 mm	110 m	1
51403	3 x 16 mm	60 m	1
51404	4 x 21 mm	40 m	1
51405	5 x 23 mm	30 m	1

Č.p.	veľkosť oka	dĺžka	
51406	6 x 24 mm	18 m	1
51407	7 x 50 mm	16 m	1
51408	8 x 32 mm	10 m	1
51410	10 x 39 mm	10 m	1

REŤAZ UZLOVÁ

DIN 5686 Zn

Č.p.	Ø drótu	dĺžka		Č.p.	Ø drótu	dĺžka	
51430	1,4 mm	150 m	1	51433	2,0 mm	118 m	1
51431	1,6 mm	150 m	1	51435	2,5 mm	70 m	1
51432	1,8 mm	150 m	1	51436	2,8 mm	50 m	1



REŤAZ DLHÉ OKO

DIN 5685 C Zn

Č.p.	veľkosť oka	dĺžka	
51412	2 x 12 mm	80 m	1
51413	3 x 26 mm	60 m	1
51414	4 x 32 mm	38 m	1
51415	5 x 35 mm	32 m	1

Č.p.	veľkosť oka	dĺžka	
51416	6 x 43 mm	18 m	1
51417	7 x 50 mm	16 m	1
51418	8 x 54 mm	10 m	1
51420	10 x 65 mm	10 m	1

REŤAZ PLASTOVÁ



Č.p.	špecifikácia	
51450	6 mm 25 m červeno-biela	1



SPOJKA LANOVÁ DVOJITÁ

DIN 5685 C Zn

Č.p.	špecifikácia	
51348	Ø 10 mm	10



SPOJKA LANOVÁ

DIN 5685 C Zn

Č.p.	špecifikácia	
51338	Ø 5 mm	10
51341	Ø 10 mm	10



OČNICA PRE LANÁ

Zn

Č.p.	špecifikácia	
51257	Ø 14 mm	10
51258	Ø 16 mm	10
51259	Ø 18 mm	10
51260	Ø 20 mm	10
51261	Ø 22 mm	10
51262	Ø 24 mm	10
51263	Ø 26 mm	10
51264	Ø 28 mm	10
51265	Ø 30 mm	10



NAVIJAK S LANOM A HÁKOM

Zn

Č.p.	nosnosť	dĺžka lana	
26720	300 kg	8 m	1
26705	450 kg	8 m	1
26721	500 kg	8 m	1
26722	800 kg	8 m	1
26706	900 kg	8 m	1
26707	1350 kg	8 m	1



STOJAN NA LANKÁ A REŤAZE

Č.p.	špecifikácia	
51196	Stojan na reťaze osadený	10
51197	Stojan na lanká osadený	10
51198	Stojan na reťaze	10
51199	Stojan na lanká	10

LANKO OCEĽOVÉ
POZINKOVANÉ

Zn

Č.p.	průměr lana	dĺžka	
51100	Ø 1 mm	500 m	1
51101	Ø 1,2 mm	500 m	1
51102	Ø 1,5 mm	500 m	1
51103	Ø 2 mm	200 m	1
51104	Ø 3 mm	200 m	1
51105	Ø 4 mm	100 m	1
51106	Ø 5 mm	75 m	1
51107	Ø 6 mm	75 m	1
51130	Ø 8 mm	75 m	1
51131	Ø 10 mm	50 m	1
51132	Ø 12 mm	50 m	1

LANKO OCEĽOVÉ
POZINKOVANÉ V PVC OBALE

Zn

Č.p.	průměr lana	dĺžka	
51108	Ø 2/3 mm	200 m	1
51109	Ø 3/4 mm	100 m	1
51110	Ø 4/5 mm	75 m	1
51111	Ø 5/6 mm	50 m	1



LANKO OCEĽOVÉ NEREZOVÉ

INOX

Č.p.	průměr lana	dĺžka	
51120	Ø 1 mm	300 m	1
51121	Ø 1,2 mm	300 m	1
51122	Ø 1,5 mm	300 m	1
51123	Ø 2 mm	200 m	1
51124	Ø 3 mm	200 m	1
51125	Ø 4 mm	100 m	1
51126	Ø 5 mm	75 m	1
51127	Ø 6 mm	75 m	1



FESTA

SVETLO STAVEBNÉ LED



Č.p.	špecifikácia
37611	

1

SVETLO STAVEBNÉ HALOGÉNOVÉ



Č.p.	špecifikácia	
37600	120 W	1
37601	400 W	1

HALOGÉNOVÁ ŽIAROVKA

Č.p.	špecifikácia	
37604	120 W	1
37606	250 W	1
37605	400 W	1



FESTA

SVETLO STAVEBNÉ LED

· maximálna výška 180 cm



Č.p.	špecifikácia
37615	20 W
37616	2 x 20 W

1

1

SVETLO STAVEBNÉ HALOGÉNOVÉ

· maximálna výška 180 cm



Č.p.	špecifikácia	
37602	400 W	2
37603	2 x 400 W	2

2

2



REBRÍK TELESKOPICKÝ

· max. nosnosť 150 kg



Č.p.	špecifikácia	
48410	3,2 m 11 priečok	1
48411	3,8 m 13 priečok	1

REBRÍK TELESKOPICKÝ SKLADACÍ

· max. nosnosť 150 kg



Č.p.	špecifikácia	
48415	1,9 / 3,8 m 6/12 priečok	1



PLOŠINA PRACOVNÁ SKLADACIA

· max. nosnosť 150 kg

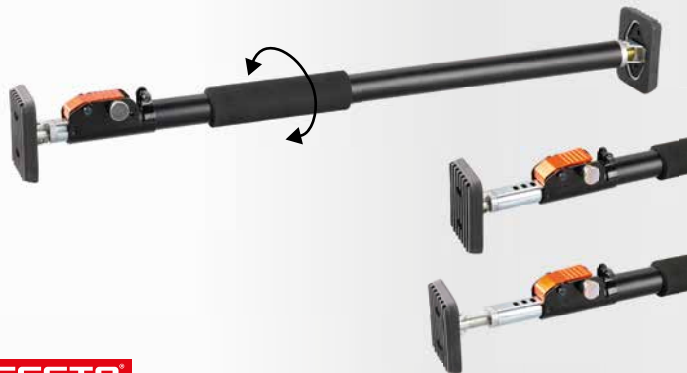

Č.p.	špecifikácia	
48420		1

**FESTA**

TYČ ROZPÍNACIA, PODPERNÁ

· max. nosnosť 40 kg



Č.p.	špecifikácia	
52060	66 - 115 cm	1
52065	160 - 290 cm	1



STOJKA DEBNIACA

· 48449 klietka na debniace stojky



Č.p.	špecifikácia	
48452	160 - 290 cm	1
48453	180 - 320 cm	1
48454	200 - 360 cm	1
48455	250 - 440 cm	1
48456	260 - 380 cm	1
48457	220 - 400 cm	1



TYČ ROZPÍNACIA, PODPERNÁ



Č.p.	špecifikácia	
52050	50 - 115 cm	1
52055	115 - 290 cm	1



SKRUTKY DO DREVA, BOX

ks	obsah balenia
60	3,0 x 12 mm
50	3,0 x 16 mm
40	3,0 x 20 mm
50	3,5 x 20 mm
40	3,5 x 30 mm
25	4,0 x 30 mm
20	4,0 x 40 mm
15	5,0 x 50 mm
10	5,0 x 60 mm

310x

Č.p. 55642 špecifikácia



1

SKRUTKY DO DREVA + HMOŽDINKY, BOX

skrutky do dreva		hmoždinky	
ks	obsah balenia	ks	obsah balenia
40	3,5 x 30 mm	40	5 x 25 mm
25	4,0 x 40 mm	25	6 x 30 mm
12	5,0 x 50 mm	12	8 x 40 mm
8	6,0 x 60 mm	8	10 x 50 mm

170x

Č.p. 55645 špecifikácia



1

SKRUTKY DO DREVA, BOX

ks	obsah balenia
350	3,0 x 16 mm
280	3,0 x 20 mm
220	3,0 x 25 mm
250	3,5 x 20 mm
240	3,5 x 25 mm
180	3,5 x 3, mm
280	4,0 x 16 mm
80	4,0 x 30 mm
40	4,0 x 40 mm
30	4,0 x 50 mm
25	5,0 x 50 mm
25	5,0 x 60 mm

2000x

Č.p. 55640 špecifikácia



1



DVIERKA KOMÍNOVÉ PLECHOVÉ



Č.p. 65062 špecifikácia



1



DVIERKA KOMÍNOVÉ KOMAX



Č.p. 65063 špecifikácia
65063 sivá
65064 biela



1



DVIERKA KOMÍNOVÉ ZINKOVANÉ



Č.p. 65065 špecifikácia



1



332

WINLAND ZÁHRADNÍCKE
NOŽNICE

338

ZÁHRADNÍCKE NOŽNICE



339

ZÁHRADNÉ PÍLY



340

MAČETY A ZÁHRADNÍCKE
NÁRADIE

341

ZÁHRADNÍCKE NÁRADIE



343

STRUNY DO KOSAČKY



344

BRÚSKY



345

PARADAJKOVÉ
A ZÁHRADNÉ TYČE

346

MULČOVACIE TEXTÍLIE



348

ZAVLAŽOVANIE AQUATIC,
ROSA

360

VOZÍKY A DRŽIAKY
NA HADICE

362

HADICOVÉ SPOJKY
MOSADZ



364

HADICOVÉ SPOJKY



365

POSTREKOVÁČE
A KOMPRESORY

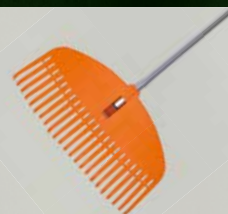

367

HRABLE



372

RÝLE, LOPATY A VIDLY



378

MOTYKY A KROMPÁČE



381

ZMETÁKY

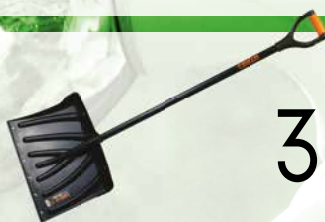

384

ZHRŇOVAČE SNEHU



386

NÁSADY DREVENÉ, ALU
A FIBERGLASS



387

SIETE PROTI HMYZU

ZÁHRADNÉ NÁRADIE
A PLETIVÁ

330 - 397



389

PLETIVÁ A VIAZACIE DRÔTY



392

KOTVIACE PÄTKY A ZEMNÉ
SKRUTKY



394

TIENIACE TKANINY,
TRSTINA, BAMBUS



395

GRILOVACIE NÁRADIE



ZÁHRADNÍCKE NOŽNICE

- Profesionálne záhradné nožnice
- Vysoká kvalita použitých materiálov
- Kvalitné spracovanie
- Ergonomické rukoväte



ZÁHRADNÍCKE NOŽNICE

· čepeľ HCS SK - 5, japonská oceľ

SK5



Č.p.	specifikace	
45020	205 mm	10
44980	náhradná pružina	1



ZÁHRADNÍCKE NOŽNICE

· čepeľ HCS SK - 5, japonská oceľ

SK5



Č.p.	specifikace	
45023	205 mm	10
44980	náhradná pružina	1



ZÁHRADNÍCKE NOŽNICE

· čepeľ HCS SK - 5, japonská oceľ

SK5



Č.p.	specifikace	
45063	215 mm	10
44981	náhradná pružina	1



ZÁHRADNÍCKE NOŽNICE

· čepeľ HCS SK - 5, japonská oceľ

SK5

TEFLON



Č.p.	specifikace	
44972	215 mm	10
44981	náhradná pružina	1



ZÁHRADNÍCKE NOŽNICE

SK5

Č.p.	specifikace	
45099	190 mm	10
44983	náhradná pružina	1



ZÁHRADNÍCKE NOŽNICE

SK5

Č.p.	specifikace	
45098	220 mm	10
44983	náhradná pružina	1



ZÁHRADNÍCKE NOŽNICE

SK5

TEFLON

Č.p.	specifikace	
45095	200 mm	10
44982	náhradná pružina	1



ZÁHRADNÍCKE NOŽNICE

• čepeľ HCS SK - 5, japonská oceľ

SK5 TEFLON

Č.p.	specifikace	
45096	220 mm	6
44982	náhradná pružina	1



ZÁHRADNÍCKE NOŽNICE

• čepeľ HCS SK - 5, japonská oceľ

SK5 TEFLON

Č.p.	specifikace	
45097	250 mm	10
44981	náhradná pružina	1



ZÁHRADNÍCKE NOŽNICE

INOX

Č.p.	specifikace	
45089	160 mm	10



ZÁHRADNÍCKE NOŽNICE

INOX

Č.p.	specifikace	
45088	160 mm	10



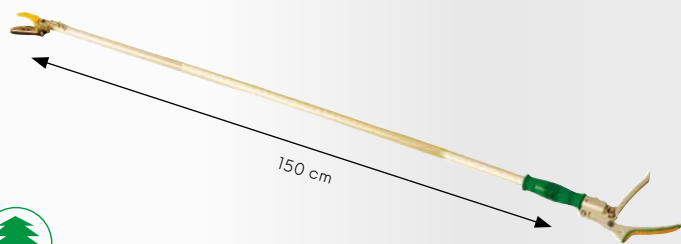

WINLAND®

ZÁHRADNÍCKE NOŽNICE PREDĹŽENÉ



10

Č.p. špecifikace

45017



WINLAND®

NÁHRADNÝ BRIT

* pre nožnice 45095, 45027

SK5 TEFLON



20

Č.p. špecifikace

45094



WINLAND®

NOŽNICE NA KONÁRE

* čepeľ HCS SK - 5, japonská oceľ

max. 45mm SK5 TEFLON



12

Č.p. špecifikace

44991 76 cm



WINLAND®

NOŽNICE NA KONÁRE TELESKOPICKÉ

* čepeľ HCS SK - 5, japonská oceľ

max. 45mm SK5 TEFLON



10

Č.p. špecifikace

44992 70 - 103 cm



WINLAND®

NÁHRADNÁ PRUŽINA

Č.p.	pre nožnice	
44981	45021, 45025, 45063, 45097	1
44980	45020, 45023	1
44983	45098, 45099	1
44982	45027, 45095, 45096	1
44984	45110, 45014, 45026	1
44985	45018	1
44986	45019, 45029, 44970	1
44987	45021	1
44988	44971	1
44989	45015, 45016	1

NOŽNICE NA KONÁRE



WINLAND®

NOŽNICE

TEFLON

Č.p.	špecifikace	
44996	61 cm, vlnité ostří	12



NOŽNICE

TEFLON



Č.p.	specifikace	
44997	61 cm, rovné ostří	12



NOŽNICE NA TRÁVU OTOČNÉ 360°



Č.p.	specifikace	
44998		6



BRÚSIČ NA NOŽE A NOŽNICE 6 V 1



Č.p.	specifikace	
45068		10



BRÚSIČ NA NOŽE A NOŽNICE



Č.p.	specifikace	
45048		20

NOŽNICE

INOX



Č.p.	specifikace	
45010	190 mm	12
44984	náhradná pružina	1

NOŽNICE

INOX



Č.p.	specifikace	
45014	190 mm	12
44984	náhradná pružina	1

NOŽNICE

INOX



Č.p.	specifikace	
45026	150 mm	12
44985	náhradná pružina	1

NOŽNICE ZÁHRADNÍCKE



Č.p.	specifikace	
45018	210 mm kované	10



ZÁHRADNÍCKE NOŽNICE

SKS TEFLON



Č.p.	specifikace
45019	210 mm

10



FESTA

ZÁHRADNÍCKE NOŽNICE

· nylonová rukoväť

SKS TEFLON NYLON



Č.p.	specifikace
45021	200 mm

6



ZÁHRADNÍCKE NOŽNICE

ALU



Č.p.	specifikace
45025	200 mm

12



ZÁHRADNÍCKE NOŽNICE

INOX



Č.p.	specifikace
44970	210 mm

10



ZÁHRADNÍCKE NOŽNICE

TEFLON



Č.p.	specifikace
45027	200 mm

10



ZÁHRADNÍCKE NOŽNICE

INOX ALU



Č.p.	specifikace
45029	200 mm

24



ZÁHRADNÍCKE NOŽNICE

INOX



Č.p.	specifikace
44971	160 mm

10



ZÁHRADNÍCKE NOŽNICE



Č.p.	specifikace
45016	180 mm

12



ZÁHRADNÍČKE NOŽNICE



PUZDRO NA ZÁHRADNÍČKÉ NOŽNICE

Č.p. 45015 specifikace 190 mm, rovné

12

Č.p. 37317 specifikace

1



NOŽNICE NA TRÁVU



NOŽNICE NA TRÁVU OTOČNÉ



Č.p. 45011 specifikace 300 mm

1

Č.p. 45012 specifikace 370 mm, otočné 180°

1



NOŽNICE NA KONÁRE

· nylonová rukoväť



Č.p. 44999 specifikace 540 mm, oblé

12



FESTA

NOŽNICE NA KONÁRE



Č.p. 45000 specifikace 750 mm, oblé

6

FESTA

NOŽNICE NA KONÁRE



Č.p. 45001 specifikace 710 mm, oblé

6

**FESTA**

NOŽNICE NA KONÁRE

TEFLON

Č.p.	specifikace	
45002	750 mm, račňové	12

**FESTA**

NOŽNICE NA KONÁRE TELESKOPICKÉ

TEFLON

Č.p.	specifikace	
45003	660-900 mm, teleskopické	6



NOŽNICE

TEFLON NYLON

Č.p.	specifikace	
44995	440 160 mm	12

**FESTA**

NOŽNICE NA KONÁRE

TEFLON

Č.p.	specifikace	
45005	580 230 mm, vlnité ostrie	6



NOŽNICE

Č.p.	specifikace	
45009	500 190 mm, vlnité ostrie	6

**FESTA**

NOŽNICE

TEFLON

Č.p.	specifikace	
45006	580 230 mm, rovné ostrie	6



NOŽNICE

Č.p.	specifikace	
45008	500 190 mm, rovné ostrie	6

**FESTA**

NOŽNICE TELESKOPICKÉ

TEFLON

Č.p.	specifikace	
45007	670-870 230 mm, vlnité ostrie	6



FESTA

PÍLA ZATVÁRACIA



· 3 x brúsené a kalené zuby



Č.p.	specifikace
45061	150 mm

12



FESTA

PÍLA ZATVÁRACIA



· 3 x brúsené a kalené zuby



Č.p.	specifikace
45060	180 mm

6



FESTA

PÍLA S PUZDROM



· 3 x brúsené a kalené zuby



Č.p.	specifikace
45062	260 mm

24



FESTA

PÍLA PREREZÁVACIA



· 3 x brúsené a kalené zuby



Č.p.	specifikace
24152	300 mm

12



FESTA

PÍLA TELESKOPICKÁ PREREZÁVACIA



· 3 x brúsené a kalené zuby

Č.p.	specifikace
45033	230 - 490 cm 340 mm

1



HÚSENICA S PÍLKOU

Č.p.	specifikace
45030	pílka 300 mm teleskopická tyč 240 cm
45031	pílka 300 mm

6

6



HÚSENICA

Č.p.	specifikace
45032	kovová húsenica bez píly

10

10



FESTA
MAČETA

TEFLON

Č.p.	specifikace	
45069	440 mm	6



FESTA
MAČETA

TEFLON

Č.p.	specifikace	
44950	490 mm	4



MAČETA NEREZ

INOX

Č.p.	specifikace	
45083	430 mm	12
45084	600 mm	6



MAČETA

rukoväť vyrobená z jaseňového dreva

Č.p.	specifikace	
45081	510 mm	36
45082	710 mm	36



LOPATKA ŠIROKÁ NEREZ

INOX

Č.p.	specifikace	
45056	360 mm	12



LOPATKA ÚZKA NEREZ

INOX

Č.p.	specifikace	
45057	350 mm	12



MOTYČKA NEREZ

INOX

Č.p.	specifikace	
45058	270 mm	12



VYPICHOVAČ BURINY S KOLÍSKOU, NEREZ

INOX

Č.p.	specifikace	
45059	370 mm	12



LOPATKA ŠIROKÁ NYLON

NYLON

Č.p.	specifikace	
45065	280 mm	1



LOPATKA ÚZKA NYLON

NYLON

Č.p.	specifikace	
45066	310 mm	1



KULTIVÁTOR RUCNÝ NYLON

NYLON

Č.p.	specifikace	
45067	290 mm	1



SADA NÁRADIA

HOBBY

4x

NYLON

Č.p.	specifikace	
45035	240 mm	35



KOLÍK SÁDZACÍ "T"

Č.p.	specifikace	
45038	280 mm	60



VYTRHÁVAČ BURINY

Č.p.	specifikace	
44955	950 mm	16



NŮŽ NA BURINU

Č.p.	specifikace	
45079	200 mm	1



NŮŽ NA BURINU

Č.p.	specifikace	
45080	200 mm „L“	1



LOPATKA SKLADACIA 3 V 1

Č.p.	specifikace	
61085	410 mm	6



SADZAČ CIBUĽOVÍN

INOX

Č.p.	specifikace	
45040	230 mm	60



ČESÁČIK NA OVOCIE

Č.p.	specifikace	
45041		75



ČESÁČIK NA OVOCIE

Č.p.	specifikace	
45039		50
45034	170 - 300 cm, teleskopická násada	5

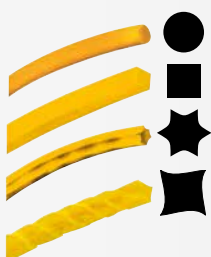

STRUNA DO KOSAČKY S NYLONOVÝM STREDOM



Č.p.	specifikace	
45530	2 mm x 15 m	1
45531	2,4 mm x 15 m	1
45532	3 mm x 15 m	1
45533	3,15 mm x 15 m	1
45534	4 mm x 15 m	1

STRUNA DO KOSAČKY



Č.p.	specifikace	
45500	1,3 mm x 15 m	30
45502	1,3 mm x 15 m	30
45503	1,6 mm x 15 m	20
45505	1,6 mm x 15 m	20
45506	2 mm x 15 m	12
45508	2 mm x 15 m	12
45517	2 mm x 15 m	10
45509	2,4 mm x 15 m	12
45511	2,4 mm x 15 m	12
45512	2,4 mm x 15 m	12
45518	2,4 mm x 15 m	10
45523	2,7 mm x 15 m	10
45524	2,7 mm x 15 m	10
45513	3 mm x 15 m	10
45515	3 mm x 15 m	10
45516	3 mm x 15 m	10
45519	3 mm x 15 m	10



STRUNA DO KOSAČKY

Č.p.	specifikace	
45520	2 mm x 162 m	10
45521	2,4 mm x 112 m	10
45528	2,7 mm x 90 m	10
45522	3 mm x 72 m	10
45525	2 mm x 162 m	10
45526	2,4 mm x 112 m	10
45529	2,7 mm x 90 m	10
45527	3 mm x 72 m	10



BRÚSKA NA KOSU-OSLA

Č.p.	specifikace	
45046	205 x 15 mm	100



BRÚSIK OVÁLNA-OSLA

Č.p.	specifikace	
45370	250 x 33 x 18 mm	20



BRÚSKA-OSLA

Č.p.	specifikace	
45045	150 x 50 x 30 mm	10

BRÚSIČ NA NOŽE
A NOŽNICE 6 V 1

Č.p.	specifikace	
45068		10

BRÚSIČ NA NOŽE
A NOŽNICE

Č.p.	specifikace	
45048		20

BRÚSIČ NA NOŽE
A NOŽNICE

Č.p.	specifikace	
16990	Ø 50 mm	50

BRÚSIČ NA NOŽE A
NOŽNICE

Č.p.	specifikace	
16991		20



VIAZACIE PÁSKY

Č.p.	specifikace	
45472	3 cm x 3 m, 3 ks	36



VIAZACIA PÁSKA

Č.p.	specifikace	
45473	3 cm x 50 m	60



VIAZACIA PÁSKA, SUCHÝ ZIPS

Č.p.	specifikace	
45471	12 mm x 5 m	1



DRÔT VIAZACÍ, PVC

Č.p.	specifikace	
45043	30 m	30

DRÔT VIAZACÍ
POGUMOVANÝ

Č.p.	specifikace	
23845	3 mm x 8 m	30
23846	4 mm x 6 m	30
23847	5 mm x 4 m	30



TYČ SKLOVLÁKNOVÁ

Č.p.	specifikace	
45036	180 cm Ø 7,9 mm	100



PÁSIK VIAZACÍ ZUBATÝ

50x

Č.p.	specifikace	
23840		20



TYČ ŠPIRÁLOVÁ K PARADAJKÁM

Č.p.	specifikace	
44041	1,2 m, Ø 5,5 mm komaxit - zelená	10
44042	1,5 m, Ø 6 mm komaxit - zelená	10
44043	1,8 m, Ø 6 mm komaxit - zelená	10
45049	1,8 m, Ø 7 mm komaxit - zelená	10
45044	1,8 m, Ø 7 mm komaxit - strieborná	10
44050	2,2 m, Ø 7 mm komaxit - zelená	10



SPOJKA PLASTOVÁ

Č.p.	specifikace	
45670	8 mm	10
45671	11 mm	10
45672	16 mm	10
45673	20 mm	10

MOQ 10



TYČ ZÁHRADNÁ POPLASTOVANÁ

Č.p.	specifikace		Č.p.	specifikace		Č.p.	specifikace	
45650	90 cm Ø 8 mm	25	45655	150 cm Ø 11 mm	25	45659	180 cm Ø 16 mm	25
45651	120 cm Ø 8 mm	25	45656	180 cm Ø 11 mm	25	45660	210 cm Ø 16 mm	25
45652	150 cm Ø 8 mm	25	45661	210 cm Ø 11 mm	25	45662	150 cm Ø 20 mm	10
45653	90 cm Ø 11 mm	25	45657	120 cm Ø 16 mm	25	45663	180 cm Ø 20 mm	10
45654	120 cm Ø 11 mm	25	45658	150 cm Ø 16 mm	25	45664	210 cm Ø 20 mm	10

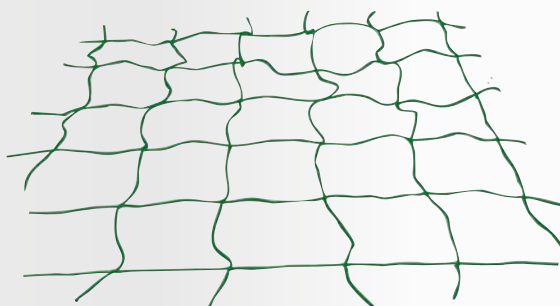

SIEŤ NA UHORKY

Č.p.	specifikace	veľkosť oka	
45560	2 x 10 m	10 x 10 cm	100

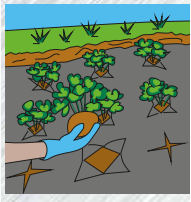

TEXTÍLIA NETKANÁ S VÝSEKMI NA VÝSADBU JAHÔD

uv STABLE 45 g/m²

Č.p.	specifikace	
45535	1,6 x 5 m	18



TEXTÍLIA NETKANÁ MULČOVACIA ČIERNA

uv STABLE 50 g/m²

Č.p.	specifikace	
45550	1,6 x 5 m	50
45551	1,6 x 10 m	20
45564	3,2 x 10 m	20
45552	1,6 x 50 m	v úlohe 1
45553	1,6 x 100 m	v úlohe 1
45562	3,2 x 50 m	v úlohe 1
45563	3,2 x 100 m	v úlohe 1



TEXTÍLIA NETKANÁ MULČOVACIA HNEDÁ

uv STABLE 50 g/m²

Č.p.	specifikace	
45556	1,6 x 5 m	50
45557	1,6 x 10 m	20
45565	3,2 x 10 m	20
45558	1,6 x 50 m	v úlohe 1
45559	1,6 x 100 m	v úlohe 1



TEXTÍLIA NETKANÁ BIELA

uv STABLE 17 g/m²

Č.p.	specifikace	
45540	1,6 x 5 m	40
45541	1,6 x 10 m	40
45542	1,6 x 50 m	v úlohe 1
45543	1,6 x 100 m	v úlohe 1



KOLÍK KOTVIACÍ NA UPEVNENIE NETKANEJ TEXTÍLIE

10x

Č.p.	specifikace	
45555	11,5 cm	1



STOLIČKA ZÁHRADNÁ, SKLADACIA

• obojstranná - kľakadlo, sedátko

Č.p.	specifikace	
45074	58 x 48 x 28 cm	4



PODLOŽKA KĽAKACIA

Č.p.	specifikace	
45086	40 x 18 x 2 cm	50



VOZÍK SYPACÍ

ROZMERY

výška	111 cm
šírka	55 cm
objem zásobníka	12 l

KULTIVÁTOR



Č.p.	specifikace	
45042	160 x 132 cm	12

KULTIVÁTOR



Č.p.	specifikace	
44053		12
61251	160 cm násada	1

Č.p.	specifikace	
45085	12 l	1



NÁDOBA PLAST - PRUŽNÁ



Č.p.	specifikace	
39192	30 l	20
39193	45 l	20

KÔŠ NA LÍSTIE, SKLADACIE

Č.p.	specifikace	
45047	55 x 70 cm, 3 držadla	20



KÔŠ SKLADACÍ

Č.p.	specifikace	
45093	40 x 25 x 23 cm	10

VAK NA LÍSTIE

Č.p.	specifikace	
44960	200 l 60 x 60 x 55 cm	50

- PROFESIONÁLNY ZAVLAŽOVACÍ SORTIMENT
- KVALITNÉ MATERIÁLY A SPRACOVANIE
- MODERNÝ DIZAJN
- KOMPATIBILNÉ S RADOU PRODUKTU ROSA

FESTA®
AQUATIC



FESTA®
AQUATIC

PIŠTOĽ

- 7 funkcií
- predná spúšť s poistkou
- ľahká regulácia prietoku



Č.p. špecifikace

45386



12



FESTA®
AQUATIC

PIŠTOĽ

- plynulá regulácia prúdu
- predná spúšť s poistkou
- ľahká regulácia prietoku



Č.p. špecifikace

45388



12



FESTA®
AQUATIC

ROZSTREKOVACĎ

- plynulá regulácia prúdu



Č.p. špecifikace

45389



24



FESTA®
AQUATIC

SADA S ROZSTREKOVACĎOM

- plynulá regulácia prúdu



Č.p. špecifikace

45385

4 ks



12



FESTA
AQUATIC
SPOJKA



1/2"

Č.p. specifikace

45390



24

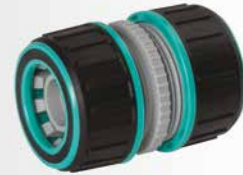

FESTA
AQUATIC
SPOJKA



3/4"

Č.p. specifikace

45391



24



FESTA
AQUATIC
RÝCHLOSPOJKA



1/2"

Č.p. specifikace

45392



24



FESTA
AQUATIC
RÝCHLOSPOJKA



3/4"

Č.p. specifikace

45393



24



FESTA
AQUATIC
STOP RÝCHLOSPOJKA



1/2"

Č.p. specifikace

45394



24



FESTA
AQUATIC
STOP RÝCHLOSPOJKA



3/4"

Č.p. specifikace

45395



24



FESTA
AQUATIC
ADAPTÉR



1/2"

3/4"

Č.p. specifikace

45396



24



FESTA
AQUATIC
ADAPTÉR



3/4"

1"

Č.p. specifikace

45397



24

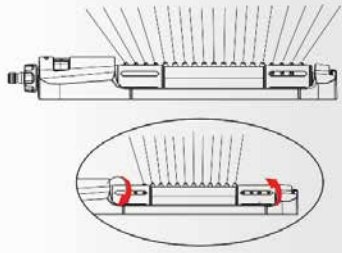

FESTA
AQUATIC

ZAVLAŽOVAČ

· 19 trysiek, z toho 8 vypínateľných

2bar min 4bar max	Max 27L/min	318 m ²
----------------------	----------------	--------------------

Č.p. špecifikace

45398



6

FESTA
AQUATIC

ZAVLAŽOVAČ

· nastaviteľné ramená s tryskami

4bar max	Max 30L/min	360°	R 6m 113m ²
----------	----------------	------	---------------------------

Č.p. špecifikace

45399



12



FESTA
AQUATIC

ROZDEĽOVAČ

· plynulá regulácia prietoku

3/4"	1"
------	----

Č.p. špecifikace

45400



6



FESTA
AQUATIC

ROZDEĽOVAČ

· plynulá regulácia prietoku

3/4"	1"
------	----

Č.p. špecifikace

45401



6



ROSA

Watering system



ROSA PIŠTOĽ

- 10 funkcií
- predná spúšť s pojistkou

0,7 bar min
5,5 bar max



Č.p. specifikace

45124

12



ROSA PIŠTOĽ

- 10 funkcií
- spúšť s poistkou
- ľahká regulácia prietoku

0,7 bar min
5,5 bar max



Č.p. specifikace

45125

12



ROSA PIŠTOĽ

- 7 funkcií
- spúšť s poistkou

0,7 bar min
5,5 bar max



Č.p. specifikace

45126

12



ROSA PIŠTOĽ DELUX

- 7 funkcií
- spúšť s poistkou
- ľahká regulácia prietoku

0,7 bar min
5,5 bar max



Č.p. specifikace

45123

kovová

12



ROSA PIŠTOĽ

- 6 funkcií
- spúšť s poistkou
- ľahká regulácia prietoku

0,7 bar min
5,5 bar max



Č.p. specifikace

45117

12



ROSA PIŠTOĽ DELUX

- 6 funkcií
- spúšť s poistkou
- ľahká regulácia prietoku

0,7 bar min
5,5 bar max



Č.p. specifikace

45118

kovová hlavica

12



ROSA PIŠTOĽ

- 5 funkcií
- spúšť s poistkou
- ľahká regulácia prietoku

0,7 bar min
5,5 bar max

Č.p. specifikace

45110



12



ROSA PIŠTOĽ

- pištoľ ružicová
- ľahká regulácia prietoku

0,7 bar min
5,5 bar max

Č.p. specifikace

45116



12



ROSA PIŠTOĽ

- kovová hlavica
- spúšť s poistkou
- ľahká regulácia prietoku

0,7 bar min
5,5 bar max

Č.p. specifikace

45120



12



ROSA PIŠTOĽ

- spúšť s poistkou
- ľahká regulácia prietoku

0,7 bar min
5,5 bar max

Č.p. specifikace

45115



12



ROSA PIŠTOĽ

- kovová
- spúšť s poistkou
- ľahká regulácia prietoku

0,7 bar min
5,5 bar max

Č.p. specifikace

45122

kovová



12



ROSA PIŠTOĽ SADA

- spúšť s poistkou
- ľahká regulácia prietoku

0,7 bar min
5,5 bar max

1/2"

2x

Č.p. specifikace

45114

1/2 rýchlospojka



12



ROSA PIŠTOĽ

- spúšť s poistkou
- ľahká regulácia prietoku

0,7 bar min
5,5 bar max

Č.p. specifikace

45111



12



ROSA ROZSTREKOVÁČ

- plynulá regulácia prúdu

0,7 bar min
5,5 bar max

Č.p. specifikace

45113



60



ROSA
ROZSTREKOVÁČ
· prúdnicový, klasické pripojenie

0,7 bar min
5,5 bar max



Č.p. specifikace
45112

32



ROSA
PIŠŤOĽ SADA

- 6 funkcií
- spúšť s poistkou
- jednoduchá regulácia prietoku

0,7 bar min
5,5 bar max

1/2"

4x



Č.p. specifikace
45181

12



ROSA
SÚPRAVA S ROZSTREKOVÁČOM
· plynulá regulácia prúdu

0,7 bar min
5,5 bar max

1/2"

4x



Č.p. specifikace
45180

12



ROSA
ROZDVOJKA - Y
· s ventilom

0,7 bar min
5,5 bar max



Č.p. specifikace
45134

12



ROSA
SPOJKA

10 bar max

1/2"

Č.p. specifikace

45140

60



ROSA
SPOJKA

10 bar max

1/2"

Č.p. specifikace

45296

MOQ 20



ROSA
RÝCHLOSPOJKA

10 bar max

1/2"

Č.p. specifikace

45142

60



ROSA
RÝCHLOSPOJKA

10 bar max

1/2"

Č.p. specifikace

45298

MOQ 20





ROSA

STOP RÝCHLOSPOJKA



Č.p. specifikace

45138

60



ROSA

STOP RÝCHLOSPOJKA



Č.p. specifikace

45294

MOQ
20



MOQ 20



ROSA

SPOJKA



Č.p. specifikace

45141

60



ROSA

SPOJKA



Č.p. specifikace

45297

MOQ
20



MOQ 20



ROSA

RÝCHLOSPOJKA



Č.p. specifikace

45143

60



ROSA

RÝCHLOSPOJKA



Č.p. specifikace

45299

MOQ
20



MOQ 20



ROSA

STOP RÝCHLOSPOJKA



Č.p. specifikace

45139

60



ROSA

STOP RÝCHLOSPOJKA



Č.p. specifikace

45295

MOQ
20



MOQ 20



ROSA

ADAPTÉR



Č.p.	specifikace	
45130	1/2" + 3/4"	60
45131	3/4" + 1"	60

ROSA

ADAPTÉR



Č.p.	specifikace	
45289	1/2" + 3/4"	MOQ 20
45290	3/4" + 1"	MOQ 20

MOQ 20



ROSA

RÝCHLOSPOJKA SADA



2x



Č.p.	specifikace	
45144		60



ROSA

REDUKCIA 1/2" - 3/4"



Č.p.	specifikace	
45213	1/2" - 3/4"	60



ROSA

SPOJOVACÍ VENTIL

* s ventilem



Č.p.	specifikace	
45135		60



ROSA

ADAPTÉR



Č.p.	specifikace	
45145		60



ROSA

ADAPTÉR



Č.p.	specifikace	
45132		60

ROSA

ADAPTÉR



Č.p.	specifikace	
45291		MOQ 20

MOQ 20





ROSA
ADAPTÉR



Č.p. specifikace
45133

60



ROSA
ADAPTÉR



Č.p. specifikace
45292

MOQ 20



ROSA
ADAPTÉR



Č.p. specifikace
45136

60



ROSA
ADAPTÉR



Č.p. specifikace
45293

MOQ 20



ROSA
ADAPTÉR



Č.p. specifikace
45137



60

ROSA
ADAPTÉR



Č.p. specifikace
45215



48



ROSA
SPOJKA



Č.p. specifikace
45218



48



ROSA
RÝCHLOSPOJKA



Č.p. specifikace
45219



48



ROSA

REDUKCIA 3/4" - 1"



Č.p. specifikace

45216

48



ROSA

ADAPTÉR



Č.p. specifikace

45217

48

ROSA

PREDAJNÁ SADA

· obsah sady

- 45113 15 ks
- 45117 10 ks
- 45120 15 ks
- 45132 40 ks
- 45131 40 ks
- 45133 40 ks
- 45142 25 ks
- 45143 20 ks
- 45140 20 ks

225x



Č.p. specifikace

45146



1



ROSA

POSTREKOVACIA HUBICA

· plynulá regulácia prúdu



Č.p. specifikace

45214

48

ROSA

**ZAVLAŽOVAČ
IMPULZNÝ**

· impulzný



Č.p. specifikace

45162

24



ROSA

ZAVLAŽOVAČ

· 8 funkcií



Č.p. specifikace

45154

48



ROSA

ZAVLAŽOVAČ

· rotačný
· 2 ramená



Č.p. specifikace

45153

24



ROSA

ZAVLAŽOVAČ

· rotačný
· 3 ramená



Č.p. specifikace

45152

24





ROSA

ZAVLAŽOVAČ VÝKYVNÝ

· 17 trysiek

0,7 bar min
5,5 bar max

ALU



Č.p. specifikace

45158

6



ROSA

ZAVLAŽOVAČ

· pyramídový

0,7 bar min
5,5 bar max



Č.p. specifikace

45167

12



ROSA

ZAVLAŽOVAČ

· hrotový

0,7 bar min
5,5 bar max



Č.p. specifikace

45160

25



ROSA

ZAVLAŽOVAČ

· konvicový s ventilom

0,7 bar min
5,5 bar max



Č.p. specifikace

45156

12



ROSA

PODSTAVEC PRE IMPULZNÝ ZAVLAŽOVAČ

· na trojnožke

0,7 bar min
5,5 bar max

3/4"



Č.p. specifikace

45155

24



ROSA

ZAVLAŽOVAČ IMPULZNÝ

· na trojnožke

0,7 bar min
5,5 bar max



Č.p. specifikace

45163 impulzný na trojnožke

20



ROSA

ČASOVAČ

· 0 - 120 min.

0,7 bar min
5,5 bar max

3/4"



Č.p. specifikace

45147

24



ROSA

ZAVLAŽOVAČ IMPULZNÝ

· mosadzný

0,7 bar min
5,5 bar max

3/4"



Č.p. specifikace

45150

12



ROSA

ZAVLAŽOVAČ IMPULZNÝ



Č.p.	specifikace	
45151		12



ROSA

ZAVLAŽOVAČ IMPULZNÝ, HROTOVÝ



Č.p.	specifikace	
45168	plastový hrot	12
45169	kovový hrot	12



ROSA

ZAVLAŽOVAČ IMPULZNÝ, HROTOVÝ



Č.p.	specifikace	
45161	plastový hrot	20



ROSA

ZAVLAŽOVAČ ROTAČNÝ, HROTOVÝ

- 3 ramená
- dvojcestný



Č.p.	specifikace	
45164	plastový hrot	12



ROSA

HROTOVÝ PODSTAVEC



Č.p.	specifikace	
45159		12



ROSA

HROTOVÝ PODSTAVEC



Č.p.	specifikace	
45179		12



ROSA

VODIČ HADICE

Č.p.	specifikace	
45186		48



ROSA

ZAVLAŽOVAČ IMPULZNÝ



Č.p.	specifikace	
45185		20

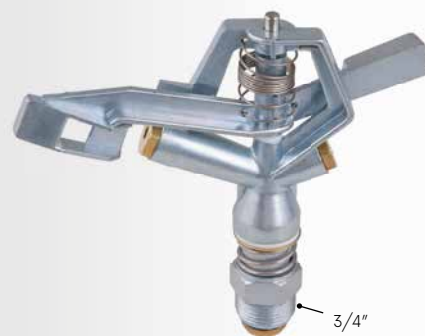

ROSA

ZAVLAŽOVAČ IMPULZNÝ



Č.p.	specifikace	
45184		20

ROSA

SADA TESNENÍ

· pre položky

45110, 45111, 45118,
45120, 45121, 45123,
45125, 45126, 45130,
45131, 45132, 45134,
45135, 45152, 45153,
45154, 45155, 45156,
45162, 45177, 45178,
45180, 45196, 45197,
45198



ROSA

TESNENIE NA SPOJKY A KONEKTORY

50x

Č.p.	specifikace	
45175		1

Č.p.	specifikace	
45187		1



ROSA

NAVÍJAČ NA HADICU

· vrátane hadice 1/2", 20 m



ROSA

DRŽIAK NA HADICU



Č.p.	specifikace	
45182	1/2" 40 m	4



Č.p.	specifikace	
45176		1



ROSA

VOZÍK NA HADICU KOVOVÝ



Č.p.	specifikace	
45183	1/2" 60 m	5

ROSA

VOZÍK NA HADICU



Č.p.	specifikace	
45177	1/2" 60 m	5

ROSA

DRŽIAK NA HADICU



Č.p.	specifikace	
45178	1/2" 60 m	5



ROSA
SPRCHA

0,7 bar min
5,5 bar max

Č.p.	specifikace	
45171	nastavitelná	12



ROSA
SPRCHA

0,7 bar min
5,5 bar max

Č.p.	specifikace	
45170	3 nohy	6



ROSA
SPRCHA - RUČNÁ

0,7 bar min
5,5 bar max

Č.p.	specifikace	
45172	s ventilom	12
45173	10 funkcií	12



ROSA
DRŽIAK HADÍC

Č.p.	specifikace	
45174		60



HADICA ZÁHRADNÁ
PRIEHĽADNÁ



Č.p.	specifikace	
45345	1/2" 25 m	1
45349	3/4" 25 m	1
45353	1" 25 m	1



HADICA ZÁHRADNÁ
NEPRIEHĽADNÁ



Č.p.	specifikace	
45360	1/2" 25 m	1
45364	3/4" 25 m	1
45366	1" 25 m	1



ROSA
ŠPIRÁLOVÁ HADICA
SADA

0,7 bar min
5,5 bar max

Č.p.	specifikace	
45300	7,5 m	6
45301	15 m	8



NOSIČ HADÍC

• max. 30 m, 1/2" záhradné hadice

Č.p.	specifikace	
45350	max. nosnosť 20 kg	1



ROSA
SPOJKA MOSADZ



Č.p. 45192 specifikace 48



ROSA
RÝCHLOSPOJKA MOSADZ



Č.p. 45194 specifikace 48



ROSA
STOP RÝCHLOSPOJKA
MOSADZ



Č.p. 45190 specifikace 48



ROSA
SPOJKA MOSADZ



Č.p. 45193 specifikace 48



ROSA
RÝCHLOSPOJKA MOSADZ



Č.p. 45195 specifikace 48



ROSA
STOP RÝCHLOSPOJKA
MOSADZ



Č.p. 45191 specifikace 48



ROSA
ADAPTÉR MOSADZ



Č.p. 45196 s vnútorným závitom 1/2" + 3/4" 48



ROSA
ADAPTÉR MOSADZ



Č.p. 45197 s vnútorným závitom 3/4" 48



ROSA
ADAPTÉR MOSADZ



Č.p. 45199 s vnútorným závitom 1" 48



ROSA
ADAPTÉR MOSADZ



Č.p. 45198 s vnútorným závitom 3/4 + 1" 48



ROSA
ADAPTÉR MOSADZ



Č.p. 45200 s vonkajším závitom 3/4" 48



ROSA
POSTREKOVACIA HUBICA MOSADZ



Č.p. 45206 nastaviteľná 48



ROSA

ADAPTÉR MOSADZ



Č.p.	specifikace	
45203	medzikus pre 2 rýchlospojky	48



ROSA

ADAPTÉR MOSADZ



Č.p.	specifikace	
45204	medzikus pre 3 rýchlospojky	48



ADAPTÉR



Č.p.	specifikace	
45211	vnútorný závit 1"	25



HADICOVÁ SPOJKA

Č.p.	specifikace	
45220	1/2" závit 3/4"	10
45221	3/4" závit 1"	10
45222	1" závit 1"	10



HADICOVÁ KONCOVKA

Č.p.	specifikace	
45223	1/2" závit 3/4"	10
45224	3/4" závit 1"	10
45225	1" závit 1"	10



HADICOVÁ REDUKCIA

Č.p.	specifikace	
45226	1/2" - 3/4" závit 1"	10
45227	1" - 3/4" závit 1"	10
45228	1" - 1/2" závit 1"	10



ROZPRAŠOVAČ

Č.p.	specifikace	
45229		10



SPONA HADICOVÁ

Zn		MOQ 2
Č.p.	priemer	
45600	8 - 12 mm	2
45601	10 - 16 mm	2
45602	12 - 20 mm	2

Č.p.	priemer	
45603	16 - 25 mm	2
45604	20 - 32 mm	2
45605	25 - 40 mm	2
45606	30 - 45 mm	2
45607	32 - 50 mm	2
45608	40 - 60 mm	2
45609	50 - 70 mm	2
45610	60 - 80 mm	2
45611	70 - 90 mm	2
45612	80 - 100 mm	2
45613	90 - 110 mm	2
45614	100 - 120 mm	2
45615	110 - 130 mm	2
45616	120 - 140 mm	2
45617	130 - 150 mm	2
45618	140 - 160 mm	2
45619	150 - 170 mm	2



SPONA HADICOVÁ

INOX		MOQ 2
Č.p.	priemer	šírka
45620	8 - 12 mm	9 mm
45621	10 - 16 mm	9 mm
45622	12 - 20 mm	9 mm

Č.p.	priemer	šírka	
45623	16 - 25 mm	9 mm	2
45624	20 - 32 mm	9 mm	2
45625	25 - 40 mm	12 mm	2
45626	30 - 45 mm	12 mm	2
45627	32 - 50 mm	12 mm	2
45628	40 - 60 mm	12 mm	2
45629	50 - 70 mm	12 mm	2
45630	60 - 80 mm	12 mm	2
45631	70 - 90 mm	12 mm	2
45632	80 - 100 mm	12 mm	2
45633	90 - 110 mm	12 mm	2
45634	100 - 120 mm	12 mm	2
45635	110 - 130 mm	12 mm	2
45636	120 - 140 mm	12 mm	2
45637	130 - 150 mm	12 mm	2
45638	140 - 160 mm	12 mm	2
45639	150 - 170 mm	12 mm	2



VENTILY A ZAVLAŽOVACIE KRHLY



VENTIL ZÁHRADNÝ DVOJITÝ

č.p.	specifikace	
45105		8



VENTIL ZÁHRADNÝ

č.p.	specifikace	
45100	1/2"	12
45101	3/4"	10
45102	1"	6



VENTIL GUĽOVÝ

č.p.	specifikace	
45106	1/2"	12
45107	3/4"	10
45108	1"	8



ROHÁČIK

č.p.	specifikace	
45104	1/2" x 3/8"	10



KRHLA PLASTOVÁ



č.p.	specifikace	
45280	2,5 l	10
45283	5 l	10
45285	10 l	10
45286	12 l	10
45287	15 l	10



FESTA

POSTREKOVACĎ TLAKOVÝ ZÁHRADNÝ 12 L

max. tlak	2,5 Bar
objem	12 l
dĺžka hadice	3 m
rozmery	32 x 25 x 59 cm



Č.p.	specifikace	
45249	postrekovač tlakový záhradný 12 l	1
45273	pištoľ náhradná	1
45274	tlaková hadica náhradná	1

FESTA

ČISTIČ VYSOKOTLAKOVÝ

napätie / frekvencia	230 V/50 Hz
príkon	1500 W
maximalný tlak	120 Bar
pracovný tlak	80 Bar
prietok vody	6 l
dĺžka hadice	5 m
krytie	IPX5
funkcie	Auto Stop



Č.p.	specifikace	
45270	čistič vysokotlakový	1
45271	pištoľ náhradná	1
45272	tlaková hadica náhradná	1



FESTA

POSTREKOVACĎ TLAKOVÝ ZÁHRADNÝ

Č.p.	specifikace	
45247	12 l	1
45248	16 l	1



Č.p.	specifikace	
45263	náhradná hadička k postrekovaču	1
45251	náhradná sada tesnení	1
45254	náhradná tryska	1
45257	náhradná rukoväť	1
45260	náhradná tyč - 370 mm	1
45267	náhradná tyč 45 - 250 cm	1
45268	náhradná tyč 65 - 260 cm	1



FESTA

POSTREKOVACĎ TLAKOVÝ ZÁHRADNÝ

Č.p.	specifikace	
45244	3 l	6
45245	5 l	6
45246	8 l	6



Č.p.	specifikace	
45262	náhradná hadička k postrekovaču	1
45250	náhradná sada tesnení	1
45253	náhradná tryska	1
45256	náhradná rukoväť	1
45261	náhradná tyč - 370 mm	1

**FESTA****POSTREKOVACĽ RUČNÝ TLAKOVÝ**

Č.p.	typ	
45242	1,5 l	20
45241	2 l	20

**TYČ K POSTREKOVACĽU TELESKOPICKÁ**

Č.p.	typ	
45267	45 - 250 cm	inox 1
45268	65 - 260 cm	fiberglass 1

**NÁHRADNÁ HADIČKA K POSTREKOVACĽU**

Č.p.	typ	
45263	pre postrekovač 45247, 45248	1
45262	pre postrekovač 45244, 45245, 45246	1

**POSTREKOVACĽ RUČNÝ**

Č.p.	typ	
45239	0,5 l	1
45240	0,7 l	1

**TYČ K POSTREKOVACĽU TELESKOPICKÁ**

Č.p.	specifikace	
45269		1

**ZVON HERBICIDNÝ**

Č.p.	velikost	dĺžka	šírka	výška	
45265	malý	230 mm	90 mm	130 mm	1
45266	veľký	370 mm	140 mm	200 mm	1

HRABLE

FESTA[®]



FESTA

HRABLE PLASTOVÉ

Č.p.	počet lamel	šírka	výška	
45327	13	240 mm	200 mm	12

system click
ON - OFF



FESTA

SET HRABLE PLASTOVÉ,
HLINÍKOVÁ NÁSADA

MOQ
3

Č.p.	počet lamel	dĺžka násady	
61136	13	160 cm	3
61147	13	100 cm	3



FESTA

HRABLE PLASTOVÉ

Č.p.	počet lamel	šírka	výška	
45328	23	480 mm	280 mm	12

system click
ON - OFF



FESTA

SET HRABLE PLASTOVÉ,
HLINÍKOVÁ NÁSADA

MOQ
3

Č.p.	počet lamel	dĺžka násady	
61137	23	160 cm	3
61148	23	100 cm	3



FESTA

HRABLE PLASTOVÉ

Č.p.	počet lamel	šírka	výška	
45329	35	760 mm	310 mm	1

system click
ON - OFF



FESTA

SET HRABLE PLASTOVÉ,
HLINÍKOVÁ NÁSADA

MOQ
3

Č.p.	počet lamel	dĺžka násady	
61138	35	160 cm	3

**FESTA**

HRABLE PLASTOVÉ

Č.p.	počet lamel	šírka	
45325	12	410 mm	12

**FESTA**SET HRABLE PLASTOVÉ,
HLINÍKOVÁ NÁSADAMOQ
3

Č.p.	počet lamel	dĺžka násady	
61139	12	160 cm	3

**FESTA**

HRABLE PLASTOVÉ

Č.p.	počet lamel	šírka	
45326	18	580 mm	12

**FESTA**SET HRABLE PLASTOVÉ,
HLINÍKOVÁ NÁSADAMOQ
3

Č.p.	počet lamel	dĺžka násady	
61140	18	160 cm	3



ULICOVÝ ZMETÁK

Č.p.	špecifikace	
45323	37 cm	16



SET ULICOVÝ ZMETÁK, NÁSADA

MOQ
3

Č.p.	špecifikace	dĺžka násady	
61149	37 cm	160 cm (45330)	3

**FESTA**

HRABLE KOVOVÉ NASTAVITELNÉ, TELESKOPICKÉ

Zn

Č.p.	počet lamel	rozsah	
44965	15	200 - 590 mm	12



HRABLE KOVOVÉ NASTAVITELNÉ

Zn

Č.p.	počet lamel	váha	rozsah	
45050	15	1200 g	200 - 590 mm	25



FESTA

HRABLE KOVOVÉ LAMELOVÉ

· pružinová ocel

Č.p.	šírka	počet lamel	
45071	55 cm	22	1



FESTA

HRABLE KOVOVÉ LAMELOVÉ, S NÁSADOU

MOQ
3

Č.p.	šírka	dĺžka násady	
61150	55 cm	160 cm	3



HRABLE KOVOVÉ LAMELOVÉ

Č.p.	šírka	počet lamel	
45051	40 cm	22	60



HRABLE KOVOVÉ LAMELOVÉ, S NÁSADOU

MOQ
3

Č.p.	šírka	dĺžka násady	
61130	40 cm	160 cm	3



HRABLE KOVOVÉ DRÔTOVÉ

Č.p.	šírka	počet lamel	
45052	45 cm	22	36



HRABLE KOVOVÉ S NÁSADOU

MOQ
3

Č.p.	šírka	dĺžka násady	
61131	45 cm	160 cm	3



HRABLE PLASTOVÉ

MADE IN
EU

Č.p.	šírka	počet lamel	
45320	60 cm	24	10



HRABLE PLASTOVÉ S NÁSADOU

MOQ
3

Č.p.	šírka	počet lamel	dĺžka násady	
61132	60 cm	24	160 cm	3



HRABLE PLASTOVÉ

MADE IN
EU

Č.p.	šírka	počet lamel	
45055	50 cm	22	10



HRABLE PLASTOVÉ S NÁSADOU

MOQ
3

Č.p.	šírka	počet lamel	dĺžka násady	
61133	50 cm	22	160 cm	3

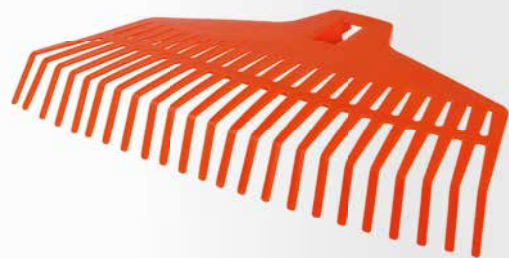

HRABLE PLASTOVÉ



Č.p.	šírka	počet lamel	
45321	40 cm	23	20



HRABLE PLASTOVÉ S NÁSADOU

MOQ
3

Č.p.	počet lamel	dĺžka násady	
61134	23	160 cm	3



HRABLE PLASTOVÉ



Č.p.	šírka	počet lamel	
45054	40 cm	23	10



HRABLE PLASTOVÉ S NÁSADOU

MOQ
3

Č.p.	šírka	počet lamel	dĺžka násady	
61135	40 cm	23	160 cm	3



HRABLE PLASTOVÉ



Č.p.	šírka	počet lamel	
45053	58 cm	16	35



HRABLE PLASTOVÉ S NÁSADOU

MOQ
3

Č.p.	šírka	počet lamel	dĺžka násady	
61141	58 cm	16	160 cm	3



HRABLE PLASTOVÉ, SO ZAROVNÁVACOU HRANOU



Č.p.	šírka	počet zubov	
45070	41 cm	14	4



HRABLE PLASTOVÉ, SO ZAROVNÁVACOU HRANOU, S NÁSADOU

MOQ
3

Č.p.	šírka	počet zubov	dĺžka násady	
61142	41 cm	14	160 cm	3

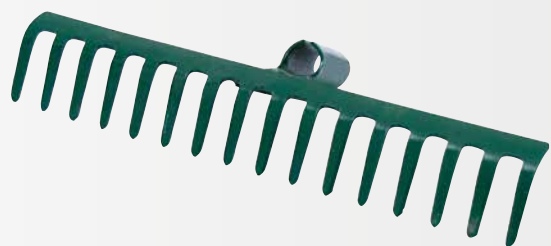

HRABLE KOVOVÉ

Č.p.	šírka	počet zubov	
61030	24 cm	10	24
61031	29 cm	12	24
61032	34 cm	14	24
61033	40 cm	16	24



HRABLE KOVOVÉ S NÁSADOU

MOQ
3

Č.p.	šírka	počet zubov	dĺžka násady	
61060	24 cm	10	160 cm	3
61061	29 cm	12	160 cm	3
61062	34 cm	14	160 cm	3
61063	40 cm	16	160 cm	3



HRABLE VERTIKUTAČNÉ KOVOVÉ

· kladivkový lak

Č.p.	šírka	počet zubov	
61045	30 cm	12	25
61046	39 cm	14	25
61047	45 cm	16	25



HRABLE VERTIKUTAČNÉ KOVOVÉ S NÁSADOU

· kladivkový lak

MOQ
3

Č.p.	šírka	počet zubov	dĺžka násady	
61143	30 cm	12	160 cm	3
61144	39 cm	14	160 cm	3
61145	45 cm	16	160 cm	3



HRABLE VERTIKUTAČNÉ

Č.p.	šírka	počet zubov	
61048	35 cm	11 21	12



HRABLE VERTIKUTAČNÉ S NÁSADOU

MOQ
3

Č.p.	šírka	počet zubov	dĺžka násady	
61146	35 cm	11 21	160 cm	3



HRABLE KOVOVÉ S NÁSADOU, FIBERGLASS

MOQ
3

Č.p.	šírka	počet zubov	dĺžka násady	
61034	34 cm	14	160 cm	3



RÝLE A LOPATY

FESTA®

FESTA

RÝĽ ŠPICATÝ MALÝ

vhodný pre prácu v skleníku

Č.p.	specifikace	dĺžka násady	
61008	19 x 28 cm	85 cm	5



FESTA

RÝĽ OBLÝ

Č.p.	specifikace	dĺžka násady	
61005	20 x 29 cm	120 cm	5

FESTA

RÝĽ ŠPICATÝ

Č.p.	specifikace	dĺžka násady	
61006	19 x 28 cm	120 cm	5

FESTA

RÝĽ OBLÝ, PREDĹŽENÝ

pre postavy vyšší 180 cm

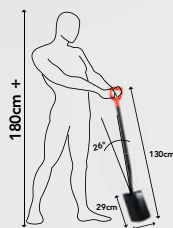

Č.p.	specifikace	dĺžka násady	
61157	20 x 29 cm	130 cm	5

FESTA

RÝĽ ŠPICATÝ, PREDĹŽENÝ

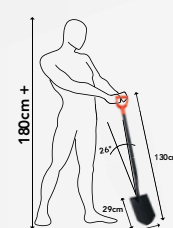

Č.p.	specifikace	dĺžka násady	
61158	19 x 28 cm	130 cm	5



FESTA

LOPATA STANDARD

Č.p.	specifikace	dĺžka násady	
61155	24 x 29 cm	120 cm	5

FESTA

VIDLE

Č.p.	specifikace	dĺžka násady	
61156	19 x 28 cm	130 cm	5



FESTA

RYČIE VIDLY

Č.p.	specifikace	dĺžka násady	
61007	18 x 28 cm	130 cm	5



RYČIE VIDLY, NÁSADA FIBERGLASS

Č.p.	specifikace	dĺžka násady	
61010	18 x 30 cm	95 cm	12



RÝĽ ŠPICATÝ, NÁSADA FIBERGLASS

Č.p.	specifikace	dĺžka násady	
61029	19 x 30 cm	95 cm	12



RÝĽ OBLÝ, NÁSADA FIBERGLASS

Č.p.	specifikace	dĺžka násady	
61015	19 x 30 cm	95 cm	12



LOPATA HLINÍKOVÁ



Č.p.	specifikace	
61026	26 x 29 cm	10
61025	34 x 30 cm	10



LOPATA HLINÍKOVÁ S NÁSADOU

· buková násada kolienko



MOQ
3

Č.p.	specifikace	dĺžka násady	
61057	26 x 29 cm	130 cm	3
61056	34 x 30 cm	130 cm	3



LOPATA UHOĽNÁ

Č.p.	specifikace	
61021	35 x 35 cm	10



LOPATA UHOĽNÁ S NÁSADOU

MOQ
3

Č.p.	specifikace	dĺžka násady	
61089	35 x 35 cm	130 cm	3



LOPATA SRDCOVKA S NÁSADOU

- kladivkový lak
- buková násada kolienko

MOQ
3

Č.p.	specifikace	dĺžka násady	
61050	26 x 28 cm	130 cm	3

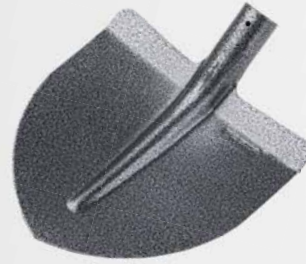

LOPATA SRDCOVKA

- kladivkový lak

Č.p.	specifikace	
61000	26 x 28 cm	12



LOPATA SRDCOVKA S NÁSADOU

- buková násada kolienko

MOQ
3

Č.p.	specifikace	dĺžka násady	
61088	26 x 28 cm	130 cm	3



LOPATA SRDCOVKA

Č.p.	specifikace	
61020	26 x 28 cm	12



LOPATA ŠTANDARD S NÁSADOU

- kladivkový lak
- buková násada kolienko

MOQ
3

Č.p.	specifikace	dĺžka násady	
61051	24 x 29 cm	130 cm	3



LOPATA ŠTANDARD

- kladivkový lak

Č.p.	specifikace	
61001	24 x 29 cm	12



LOPATA ŠTANDARD S NÁSADOU

- buková násada kolienko

MOQ
3

Č.p.	specifikace	dĺžka násady	
61090	24 x 29 cm	130 cm	3
61053	24 x 29 cm	130 cm "T _n " násada	3



LOPATA ŠTANDARD

Č.p.	specifikace	
61022	24 x 29 cm	12





LOPATA HOLŠTÝNSKA

Č.p.	specifikace	
61058	25 x 27 cm	12



LOPATA HOLŠTÝNSKA S NÁSADOU

• buková násada kolienko

MOQ
3

Č.p.	specifikace	dĺžka násady	
61059	25 x 27 cm	130 cm	3



LOPATA ÚZKA

• kladivkový lak

Č.p.	specifikace	
61002	19 x 27 cm	12



LOPATA ÚZKA S NÁSADOU

• kladivkový lak
• buková násada kolienko

MOQ
3

Č.p.	specifikace	dĺžka násady	
61052	19 x 27 cm	130 cm	3



LOPATA ÚZKA

Č.p.	specifikace	
61024	19 x 27 cm	12



LOPATA ÚZKA S NÁSADOU

• buková násada kolienko

MOQ
3

Č.p.	specifikace	dĺžka násady	
61054	19 x 27 cm	130 cm	3



RÝĽ ŠPICATÝ

• kladivkový lak

Č.p.	specifikace	
61004	22 x 30 cm	12



RÝĽ ŠPICATÝ S "T" NÁSADOU

• kladivkový lak

MOQ
3

Č.p.	specifikace	dĺžka násady	
61161	22 x 30 cm	90 cm	3



RÝĽ ŠPICATÝ S "T" NÁSADOU

MOQ
3

Č.p.	specifikace	dĺžka násady	
61097	19 x 30 cm	90 cm	3



RÝĽ ŠPICATÝ

Č.p.	specifikace	
61019	22 x 30 cm	12



RÝĽ KOVANÝ, ŠPICATÝ, S "T" NÁSADOU

Č.p.	specifikace	dĺžka násady	MOQ
61162	22 x 25 cm	90 cm	3
61223	násada	90 cm	1



RÝĽ KOVANÝ, ŠPICATÝ

Č.p.	specifikace	
61013	22 x 25 cm	12



RÝĽ OBLÝ S "T" NÁSADOU

· kladivkový lak

MOQ
3

Č.p.	specifikace	dĺžka násady	
61163	21 x 30 cm	90 cm	3



RÝĽ OBLÝ

· kladivkový lak

Č.p.	specifikace	
61003	21 x 30 cm	12



RÝĽ OBLÝ S "T" NÁSADOU

MOQ
3

Č.p.	specifikace	dĺžka násady	
61098	21 x 30 cm	90 cm	3



RÝĽ OBLÝ

Č.p.	specifikace	
61018	21 x 30 cm	12





RÝĽ ŠTYCHAR

Č.p.	specifikace	
61014	14 x 37 cm	12



RÝĽ ŠTYCHAR S "T" NÁSADOU

Č.p.	specifikace	dĺžka násady	
61164	14 x 37 cm	90 cm	MOQ 3
61203	násada	90 cm	1



VIDLY NA SENO

Č.p.	specifikace	
61009	20 x 32 cm	12



VIDLY NA SENO S NÁSADOU

Č.p.	specifikace	dĺžka násady	
61165	20 x 32 cm	90 cm	MOQ 3



VIDLY RYCIE KOVANÉ

Č.p.	specifikace	
61012	22 x 30 cm	12



VIDLY RYCIE KOVANÉ S "T" NÁSADOU

Č.p.	specifikace	dĺžka násady	
61166	22 x 30 cm	90 cm	MOQ 3
61222	násada	90 cm	1



VIDLY RYCIE

Č.p.	specifikace	
61044	20 x 30 cm	12



VIDLY RYCIE S "T" NÁSADOU

Č.p.	specifikace	dĺžka násady	
61028	20 x 30 cm	90 cm	MOQ 3
61209	násada	90 cm	1

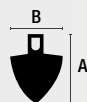

MOTYKA KOVANÁ, ŠPICATÁ, S NÁSADOU

Č.p.	specifikace	dĺžka násady	MOQ	
61111	0,4 kg	120 cm	3	
61112	0,6 kg	120 cm	3	
61224	násada	120 cm	1	

MOTYKA KOVANÁ, ŠPICATÁ

Č.p.	specifikace	A	B	
61035	0,4 kg	180 mm	125 mm	1
61036	0,6 kg	230 mm	160 mm	30

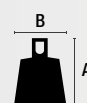

MOTYKA PLOCHÁ, KOVANÁ, S NÁSADOU

Č.p.	specifikace	dĺžka násady	MOQ	
61114	0,6 kg	120 cm	3	
61224	násada	120 cm	1	

MOTYKA KOVANÁ, PLOCHÁ

Č.p.	specifikace	A	B	
61038	0,6 kg	165 mm	135 mm	20



MOQ
3

KROMPÁČ KOVANÝ S NÁSADOU

Č.p.	specifikace	dĺžka násady	MOQ	
61121	1,5 kg	95 cm	3	
61042	2,5 kg	95 cm	3	

KROMPÁČ KOVANÝ

Č.p.	specifikace	MOQ	
61120	1,5 kg	6	
61040	2,5 kg	6	





MOTYKA

Č.p.	specifikace	
61067	75 mm	1
61068	125 mm	1
61069	175 mm	1



MOTYKA S NÁSADOU

MOQ
3

Č.p.	specifikace	délka násady	
61290	75 mm	120 cm	3
61291	125 mm	120 cm	3
61292	175 mm	120 cm	3



MOTYKA SRDCOVÁ

Č.p.	specifikace	
61070	140 mm	40



MOTYKA SRDCOVÁ S NÁSADOU

MOQ
3

Č.p.	specifikace	délka násady	
61293	140 mm	120 cm	3



MOTYKA PLOCHÁ S NÁSADOU

Č.p.	specifikace	délka násady	
61294	140 mm	27 cm	MOQ 3
61221	násada	27 cm	1



MOTYKA SRDCOVÁ S NÁSADOU

Č.p.	specifikace	délka násady	
61295	140 mm	27 cm	MOQ 3
61221	násada	27 cm	1



MOTYKA PLEČKA S NÁSADOU

Č.p.	specifikace	délka násady	
61296	175 mm	27 cm	MOQ 3
61221	násada	27 cm	1



KYPRIČ TROJ (3) HROTÝ S NÁSADOU

Č.p.	specifikace	délka násady	
61297		27 cm	MOQ 3
61221	násada	27 cm	1



120 cm

80 cm



• ilustračné foto

REKLAMNÝ STOJAN NA LOPATY A RÝLE

Č.p.	specifikace	
61077	stojan osadený	1
61079	stojan na palete	1



• ilustračné foto

DRŽIAK ZÁHRADNÉHO NÁRADIA

Č.p.	specifikace	
51185	45 cm	15



• otočné gumové valčeky

DRŽIAK ZÁHRADNÉHO NÁRADIA

5x		
Č.p.	specifikace	
51184		12



KOSÁK

Č.p.	specifikace	
45490	450 mm	1



FESTA

KEFA OCEĽOVÁ

Č.p.	specifikace		
22135	6 x 19 cm	bez násady	8
22137	6 x 19 cm	s násadou 140 cm	MOQ 3



FESTA

KEFA NYLONOVÁ

Č.p.	specifikace		
22136	6 x 19 cm	bez násady	8
22138	6 x 19 cm	s násadou 140 cm	MOQ 3



KEFA OCEĽOVÁ NA ČISTENIE ŠKÁR S NÁSADOU

Č.p.	dĺžka násady		
52198	140 cm		1



METLIČKA



Č.p.	specifikace		
52119	29 cm		24



METLIČKA S LOPATKOU



Č.p.	specifikace		
52168			26



METLIČKA S LOPATKOU



Č.p.	specifikace		
52173			26



FESTA

LOPATKA PLECHOVÁ - ZOSILNENÁ

Č.p.	specifikace		
52176	22 x 23 cm		24

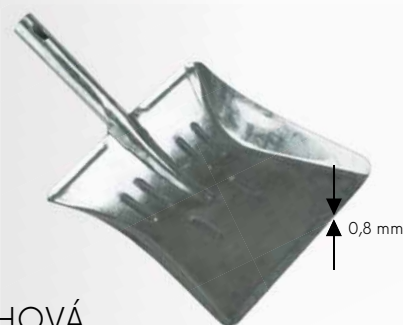

LOPATKA PLECHOVÁ

Zn

Č.p.	specifikace		
52175	22 x 23 cm		50

ZMETÁK S NÁSADOU



Č.p.	specifikace	MOQ
52197	30 cm 120 cm drevená	3



ZMETÁK



Č.p.	specifikace	MOQ
52108	30 cm hrubý závit	25
61172	násada 120 cm hrubý závit	1



SET ZMETÁK S NÁSADOU

Č.p.	specifikace	dĺžka násady	MOQ
61149	37 cm	160 cm	3

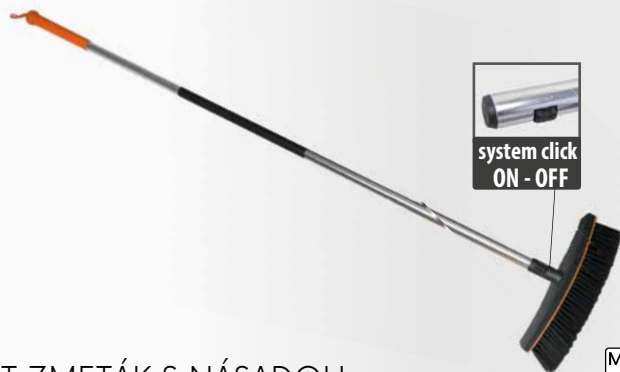

ZMETÁK

Č.p.	specifikace	MOQ
45323	37 cm	16



ZMETÁK S NÁSADOU



Č.p.	specifikace	dĺžka násady	MOQ
52190	30 cm	150 cm	3
52191	40 cm	150 cm	3
52192	50 cm	150 cm	3
52193	60 cm	150 cm	3
52194	80 cm	150 cm	3



ZMETÁK



Č.p.	specifikace	MOQ
52101	30 cm	10
52102	40 cm	10
52103	50 cm	10
52104	60 cm	10
52105	80 cm	10



SÁLOVÝ ZMETÁK S NÁSADOU



Č.p.	specifikace	dĺžka násady	MOQ
52185	40 cm	150 cm	3
52186	50 cm	150 cm	3
52187	60 cm	150 cm	3
52188	70 cm	150 cm	3
52189	80 cm	150 cm	3



SÁLOVÝ ZMETÁK



Č.p.	specifikace	MOQ
52160	40 cm	10
52161	50 cm	10
52162	60 cm	10
52163	70 cm	10
52164	80 cm	10





ZMETÁK



Č.p.	specifikace		
52114	28 cm	hrubý závit	1



ZMETÁK S NÁSADOU



Č.p.	specifikace	délka násady	
52116	28 cm	s násadou 130 cm	3

MOQ
3



ZMETÁK



Č.p.	specifikace		
52113	30 cm	hrubý závit	26
52115	30 cm	bez závitů	26



ZMETÁK S NÁSADOU



Č.p.	specifikace		
52195	30 cm	150 cm dřevěná	3
52196	30 cm	130 cm ALU	3

MOQ
3



Ø 23 mm

STIERKA S GUMOU

Č.p.	specifikace		
15886	450 mm	násada Ø 23 mm	48
15887	600 mm	násada Ø 23 mm	48
15888	750 mm	násada Ø 23 mm	32



ULICOVÝ ZMETÁK S NÁSADOU



Č.p.	specifikace		
52109	25 cm	120 cm dřevěná	12

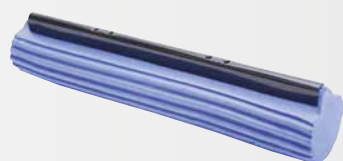

NÁHRADNÝ MOP

Č.p.	specifikace		
52111	30 cm		1



ČISTIACI MOP

Č.p.	specifikace		
52110	30 cm		16



ZHRŇOVAČE SNEHU

**FESTA**

ZHRŇOVAČ SNEHU

Č.p.	specifikace	
60006	46 x 34 cm	12
60206	46 x 34 cm, zložený	1

**FESTA**

ZHRŇOVAČ SNEHU

Č.p.	specifikace	
60008	50 x 34 cm	12
60208	50 x 34 cm, zložený	1



ZHRŇOVAČ SNEHU

MADE IN
EU

Č.p.	specifikace	
60001	48 x 40 cm	10
60201	48 x 40 cm, zložený	1



ZHRŇOVAČ SNEHU

ALU

Č.p.	specifikace	
60012	50 x 38 cm	12
60212	50 x 38 cm, zložený	1



SEKÁČ NA ĽAD

MOQ
3

Č.p.	specifikace	
60022	20 cm	3



SEKÁČ NA ĽAD

Č.p.	specifikace	
60018	15 cm	20
60019	20 cm	24
60020	30 cm	20
61201	násada 130 cm	10



POSYPOVÁ SOĽ

Č.p.	specifikace	
43300	10 kg	1
43301	25 kg	1



NÁSADA NA ZMETÁK

ALU

Č.p.	specifikace	
52125	130 cm, jemný závit	1
52126	130 cm, hrubý závit	1

NÁSADA NA ZMETÁK

MADE IN EU

Č.p.	specifikace	
61172	120 cm drevená násada s hrubým závitom	1
61192	150 cm drevená násada	pro 52195 1
61193	150 cm drevená násada	pro 52185 - 94 1
61194	140 cm drevená násada s hrubým závitom	1



Ø 22 mm

NÁSADA NA ZMETÁK

MADE IN EU

Č.p.	specifikace		Č.p.	specifikace	
61171	1,2 m	1	61175	1,6 m	1
61173	1,4 m	1	61176	1,7 m	1
61174	1,5 m	1	61177	1,8 m	1



NÁSADA NA VIDLY A LOPATU - KOLIENKO



Č.p.	specifikace	
61200	130 cm	10



NÁSADA NA LOPATU



Č.p.	specifikace	
61201	130 cm, rovná	10

FESTA

system click
ON - OFF

NÁSADA HLINÍKOVÁ

ALU

Č.p.	specifikace	
45330	161 cm	24
45331	100 cm	24



NÁSADA NA RÝĽ "T"



Č.p.	specifikace	
61208	90 cm	10



NÁSADA NA LOPATU "T"



Č.p.	specifikace	
61202	130 cm, rovná	10



NÁSADA NA MURÁRSKU NABERAČKU



Č.p.	specifikace	
61215	160 cm	10



NÁSADA NA RÝĽ "Y,"



Č.p.	specifikace	
61207	100 cm	10



NÁSADA NA KROMPÁČ



Č.p.	specifikace	
61204	95 cm, úzká (pro 61120)	10
61205	95 cm	10



NÁSADA NA MOTYKU



Č.p.	specifikace	
61219	120 cm	10



NÁSADA NA ŽELEZNÉ HRABLE



Č.p.	specifikace	
61183	150 cm	10
61184	160 cm	10
61189	170 cm	10
61190	180 cm	10



NÁSADA NA PLASTOVÉ HRABLE



Č.p.	specifikace	
61195	120 cm	10



NÁSADA NA HRABLE



Č.p.	specifikace	vhodné pro	
61250	160 cm	45051, 61048	20
61251	160 cm	45052	20
61252	160 cm	45320	20
61253	160 cm	45053	20
61254	160 cm	45054	20
61255	160 cm	45070	20
61256	160 cm	45055	20



PLASTOVÁ RÚČKA "Y" NA NÁSADU

Č.p.	specifikace	
61230		10

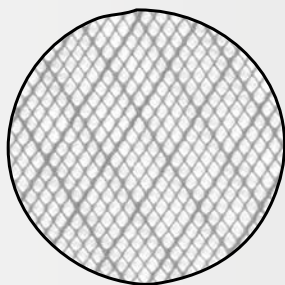

SIEŤ PROTI HMYZU

Č.p.	specifikace	
40100	1 x 25 m - PE biela	1
40120	1,2 x 25 m - PE biela	1

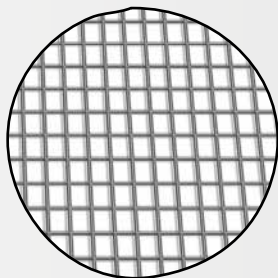

SIEŤ PROTI HMYZU

ALU Zn

Č.p.	specifikace	
42101	1 x 30 m - ALUMINIUM	2
42103	1 x 30 m - galvanizovaný drôt	2

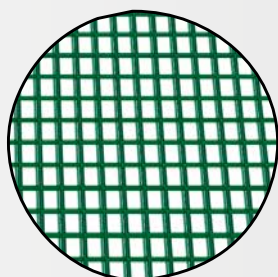

SIEŤ PROTI HMYZU

Č.p.	specifikace	
42102	1 x 30 m - zelený lakovaný oceľový drôt	2

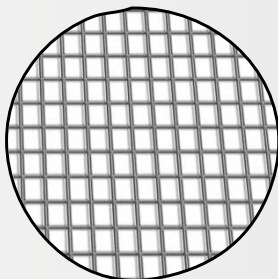

SIEŤ PROTI HMYZU - SKLOVLÁKNO

Č.p.	specifikace	
41083	0,8 x 30 m biela	6
41103	1 x 30 m biela	6
41123	1,2 x 30 m biela	6
41153	1,5 x 30 m biela	6

Č.p.	specifikace	
41082	0,8 x 30 m biela-sivá	6
41102	1 x 30 m biela-sivá	6
41122	1,2 x 30 m biela-sivá	6
41152	1,5 x 30 m biela-sivá	6

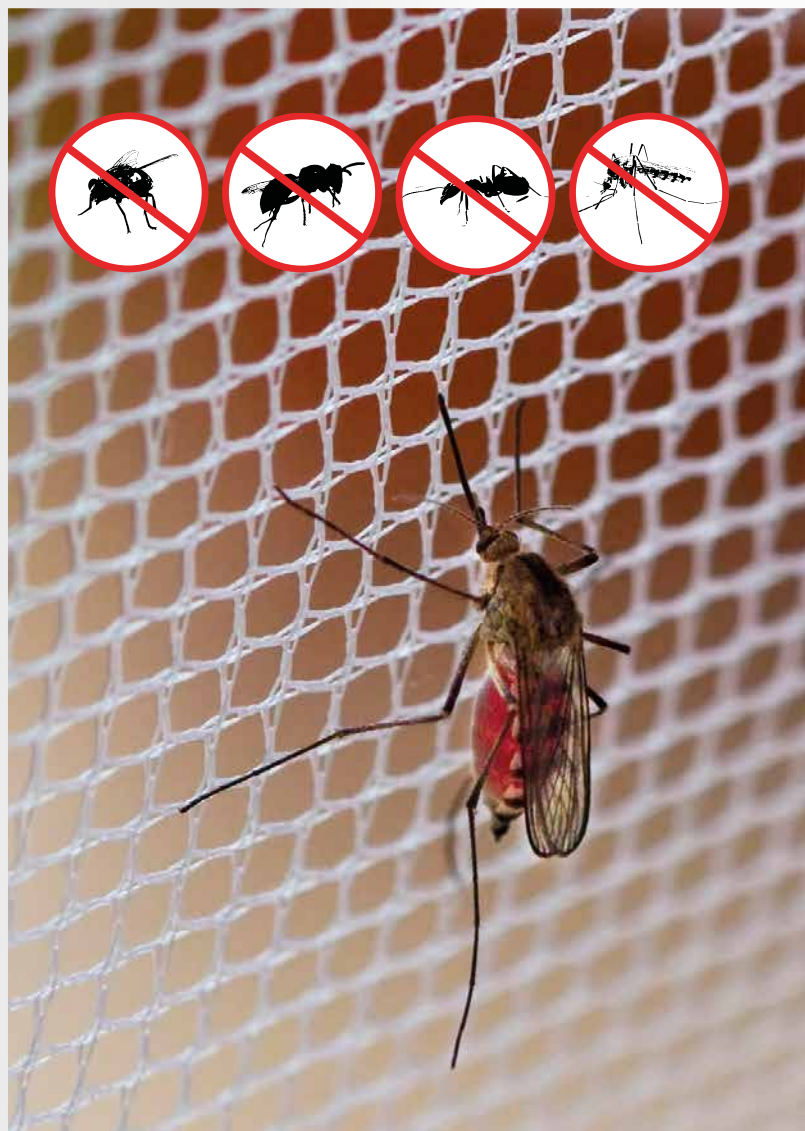

SIETE PROTI HMYZU

Č.p.	specifikace	
41050	0,5 x 30 m sivá	6
41080	0,8 x 30 m sivá	6
41100	1 x 30 m sivá	6
41120	1,2 x 30 m sivá	6
41150	1,5 x 30 m sivá	6

Č.p.	specifikace	
41081	0,8 x 30 m čierna	6
41101	1 x 30 m čierna	6
41121	1,2 x 30 m čierna	6
41151	1,5 x 30 m čierna	6

NEW



DVERNÝ ZÁVES PROTI HMYZU MAGNETICKÝ, ANTRACIT



Č.p.	specifikace	
40077	100 x 220 cm	1



DVERNÝ ZÁVES PROTI HMYZU

· variabilný rozmer 60 - 120 cm

Č.p.	specifikace	
40075	4 x 35 x 220 cm biela	20
40076	4 x 35 x 220 cm čierna	20



OKENNÁ SIEŤ SO SUCHÝM ZIPSOM - BIELA



Č.p.	specifikace	
40050	150 x 130 cm	5,6 m
40052	150 x 180 cm	6,6 m
40054	150 x 90 cm	4,8 m
40056	220 x 75 cm 2 ks	5,8 m

OKENNÁ SIEŤ SO SUCHÝM ZIPSOM - ŠEDÁ



Č.p.	specifikace	
40051	150 x 130 cm	5,6 m
40053	150 x 180 cm	6,6 m
40055	150 x 90 cm	4,8 m



OKENNÁ SIEŤ SO SUCHÝM ZIPSOM - ČIERNA



Č.p.	specifikace	
40057	150 x 130 cm	5,6 m
40058	150 x 180 cm	6,6 m
40059	150 x 90 cm	4,8 m

SUCHÝ ZIPS SAMOLEPIACI PRE OKENNÉ SIEŤE

Č.p.	specifikace	
40060	9 mm 7 m	1



PLETIVO HEX

zinkované pred spletením

Zn

Č.p.	specifikace	
42150	13 0,7 x 1000 mm - 50 m	1
42151	16 0,7 x 1000 mm - 50 m	1
42152	20 0,7 x 1000 mm - 50 m	1
42153	25 0,8 x 1000 mm - 50 m	1

PLETIVO HEX

Zn

Č.p.	specifikace	
42155	13 0,7 x 1000 mm - 50 m	1
42156	16 0,7 x 1000 mm - 50 m	1
42157	20 0,7 x 1000 mm - 50 m	1
42158	25 0,8 x 1000 mm - 50 m	1

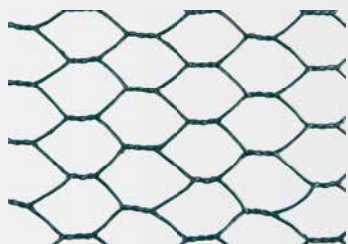

PLETIVO HEX POPLASTOVANÉ

Zn

Č.p.	specifikace	
42160	13 1 x 1000 mm - 25 m	1
42161	16 1 x 1000 mm - 25 m	1
42162	20 1 x 1000 mm - 25 m	1
42163	25 1 x 1000 mm - 25 m	1

OKRASNÉ PLETIVO POPLASTOVANÉ

Č.p.	veľkosť oka	Ø drátu	výška	length	
42175	15 x 9 mm	2 mm	40 cm	25 m	1
42176	15 x 9 mm	2 mm	65 cm	25 m	1
42177	15 x 9 mm	2 mm	90 cm	25 m	1
42178	15 x 9 mm	2 mm	120 cm	25 m	1
42179	15 x 9 mm	2 mm	25 cm	25 m	1

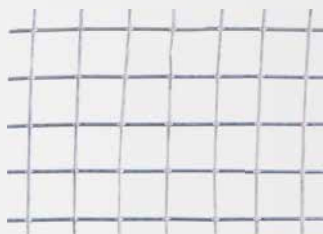

PLETIVO ŠTVOREC

Zn

Č.p.	specifikace		Č.p.	specifikace	
42185	6 0,65 x 1000 mm - 25 m	1	42174	25 1,4 x 1000 mm - 25 m	1
42170	10 0,8 x 100 mm - 25 m	1	42186	13 1,05 x 1000 mm - 25 m	1
42171	13 0,8 x 1000 mm - 25 m	1	42187	25 2,0 x 1000 mm - 25 m	1
42172	16 1,2 x 1000 mm - 25 m	1	42188	50 2,0 x 1000 mm - 25 m	1
42173	19 1,4 x 1000 mm - 25 m	1			

PLETIVO ŠTVOREC - POPLASTOVANÉ

Č.p.	specifikace	
42180	13 1,2 x 1000 mm - 25 m	1
42181	16 1,2 x 1000 mm - 25 m	1
42182	25 2,3 x 1000 mm - 25 m	1

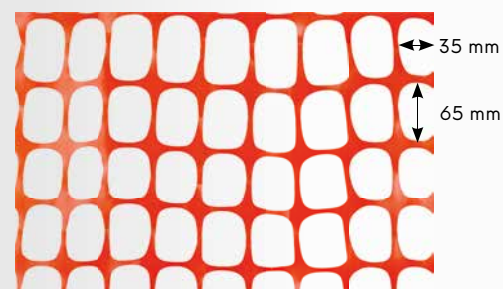

SIĚŤ PROTI VTÁKOM



Č.p.	specifikace	
45570	2 x 5 m 18 x 18 mm	45
45571	2 x 10 m 18 x 18 mm	28
45572	4 x 5 m 18 x 18 mm	24
45573	4 x 10 m 18 x 18 mm	15

BEZPEČNOSTNÁ SIĚŤ



Č.p.	specifikace	
42190	1,2 x 50 m HDPE 140g/m ²	1

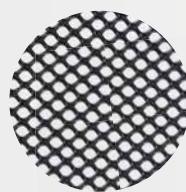

PLETIVO RABICOVÉ



Č.p.	specifikace	
42312	1 m 50 bm, 16 x 16 mm	1

OCHRANA STROMOV PROTI OHRYZENIU

* samosvorná



Č.p.	specifikace	
45580	Ø 11 x 80 cm	1



VIAZACÍ DRÔT

Zn

Č.p.	Ø drátu	délka drátu	
42203	0,6 mm	30 m	50

VIAZACÍ DRÔT

Zn

Č.p.	Ø drátu	délka drátu	
42207	0,8 mm	50 m	40
42208	0,8 mm	100 m	20
42209	0,9 mm	100 m	20
42240	1,0 mm	50 m	40
42210	1,0 mm	100 m	20
42211	1,2 mm	50 m	40
42212	1,2 mm	100 m	20
42213	1,4 mm	30 m	40
42214	1,4 mm	50 m	20
42217	1,8 mm	30 m	40
42218	1,8 mm	50 m	20

NAPÍNACÍ DRÔT

Zn

Č.p.	Ø drátu	délka drátu	
42219	2,0 mm	26 m	20
42220	2,0 mm	52 m	20
42221	2,0 mm	78 m	20
42228	3,15 mm	26 m	10
42229	3,15 mm	52 m	10
42230	3,15 mm	78 m	10

DRÔT VIAZACÍ

Č.p.	Ø drátu	délka drátu	povrch	
42201	0,6 mm	30 m	PVC	50
42202	0,9 mm	30 m	PVC	50



DRÔT VIAZACÍ

Č.p.	Ø drátu	délka drátu	
42244	1,4 mm	50 m	20
42248	1,8 mm	50 m	20
42249	2,0 mm	50 m	20



DRÔT NAPÍNACÍ

Č.p.	Ø drátu	délka drátu	
42251	2,6 mm	26 m	20
42252	2,6 mm	52 m	20
42253	2,6 mm	78 m	20
42255	3,4 mm	26 m	10
42256	3,4 mm	52 m	10
42257	3,4 mm	78 m	10





OSTNATÝ DRÔT

Zn			
Č.p.	Ø drátu	dĺžka drátu	
42260	1,7 mm	50 m	1
42261	1,7 mm	100 m	1

SVORKA NAPÍNACIEHO DRÔTU

INOX			MOQ 50
Č.p.	specifikace		
50040	nerez hrot, zelená	50	
50041	nerez hrot, čierna	50	

SVORKA NAPÍNACIEHO DRÔTU

10x		
Č.p.	specifikace	
50042		10



PLOTOVÝ NAPINÁK MALÝ

Zn		
Č.p.	specifikace	
50030	pozink malý	50
50032	PVC malý	50

PLOTOVÝ NAPINÁK VEĽKÝ

Zn		
Č.p.	specifikace	
50031	pozink	50
50033	PVC	50



PLOTOVÝ NAPINÁK MALÝ LT

Zn		
Č.p.	specifikace	
50037	pozink	50
50038	PVC	50

NAPÍNACIE ZARIADENIE

Č.p.	specifikace	
50035	2 t	6
50036	4 t	4

NEW

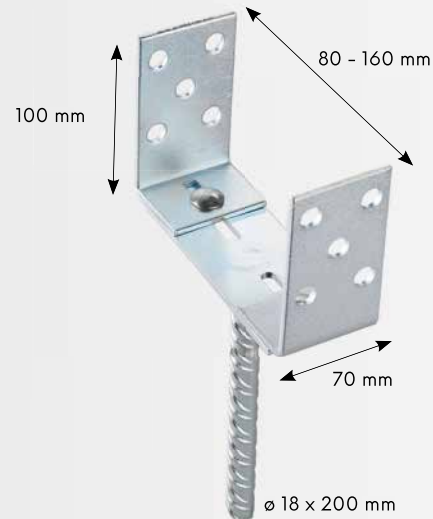

KOTVIACA PÄTKA STĽPIKA STAVITELNÁ

Zn

Č.p.	specifikace	tl.		
55465	80 - 160 x 70 mm	100 mm	4 mm	1



Ø 18 x 200mm

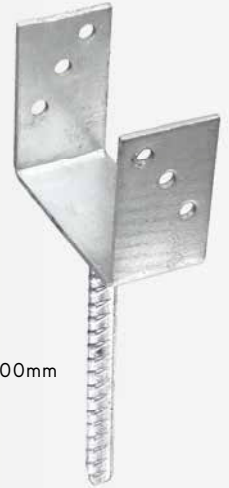

Ø 18 x 200mm

KOTVIACA PÄTKA STĽPIKA

Zn

Č.p.	specifikace	tl.	
55436	70 x 75 mm	110 mm	4 mm
55437	80 x 90 mm	130 mm	4 mm

KOTVIACA PÄTKA STĽPIKA

Zn

Č.p.	specifikace	tl.	
55429	70 x 60 mm	100 mm	4 mm
55433	81 x 60 mm	100 mm	4 mm
55430	91 x 60 mm	100 mm	4 mm
55431	101 x 60 mm	100 mm	4 mm
55432	121 x 60 mm	100 mm	4 mm



KOTVIACA PÄTKA STĽPIKA

Zn

Č.p.	Ø pätky	dĺžka pätky	hrúbka materiálu	
55400	71 x 71 mm	750 mm	2 mm	1
55401	91 x 91 mm	750 mm	2 mm	1
55406	81 x 81 mm	750 mm	2 mm	1
55402	91 x 91 mm	900 mm	2 mm	1
55403	101 x 101 mm	900 mm	2 mm	1
55404	121 x 121 mm	900 mm	2 mm	1
55405	151 x 151 mm	900 mm	2 mm	1



KOTVIACA PÄTKA STĽPIKA

Zn

Č.p.	Ø pätky	dĺžka pätky	hrúbka materiálu	
55420	71 x 71 mm	150 mm	2 mm	1
55425	81 x 81 mm	150 mm	2 mm	1
55421	91 x 91 mm	150 mm	2 mm	1
55422	101 x 101 mm	150 mm	2 mm	1
55423	121 x 121 mm	150 mm	2 mm	1
55424	151 x 151 mm	150 mm	2 mm	1

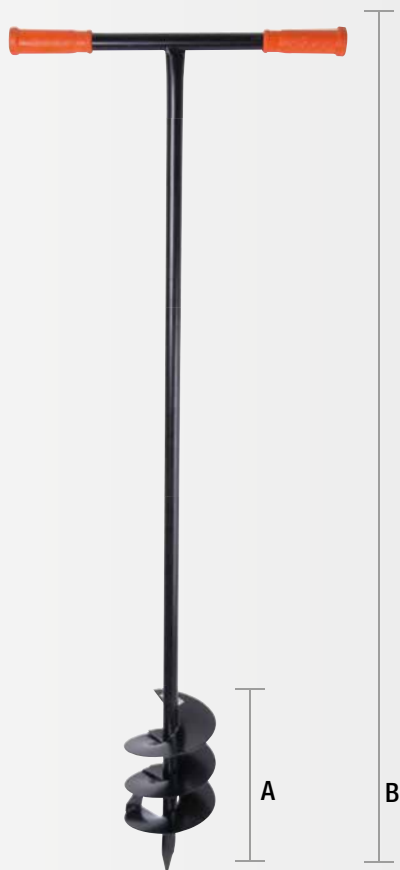

PŮDNÝ VRTÁK

Č.p.	Ø	A	B	
61299	110 mm	270 mm	1200 mm	1
61300	140 mm	270 mm	1200 mm	1
61301	170 mm	270 mm	1200 mm	1
61302	200 mm	270 mm	1200 mm	1

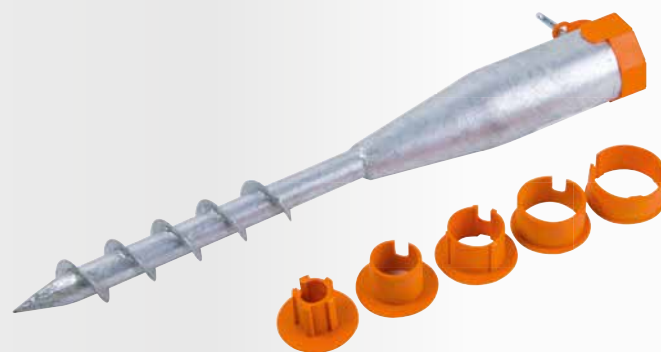

ZEMNÝ VRUT

· redukcia

- Ø 24 mm
- Ø 35 mm
- Ø 40 mm
- Ø 48 mm
- Ø 55 mm

Zn 6x

Č.p.	Ø pätky	dĺžka pätky	specifikace	
55450	60 mm	550 mm	1 ks + 5x redukcia	8

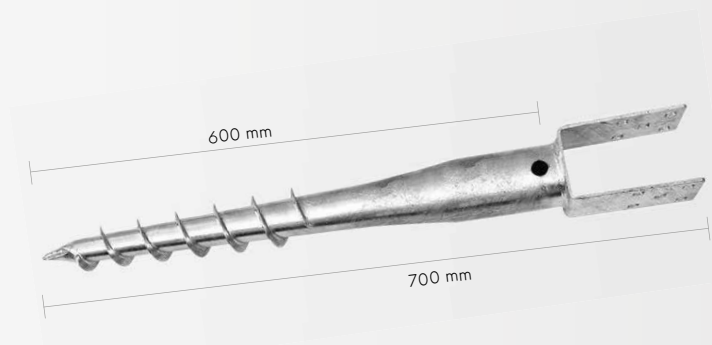

ZEMNÝ VRUT "U"

Zn

Č.p.	Ø pätky	dĺžka pätky	hrúbka materiálu	
55455	71 x 60 mm	100 mm	4 mm	1
55452	81 x 60 mm	100 mm	4 mm	1
55456	90 x 60 mm	100 mm	4 mm	1
55453	101 x 60 mm	100 mm	4 mm	1
55457	110 x 60 mm	100 mm	4 mm	1
55454	121 x 60 mm	100 mm	4 mm	1



PÄTKA STĽPIKA S NASTAVITEĽNOU SKRUTKOU

Zn

Č.p.	Ø pätky	výška pätky	závit	
55460	80 x 80 mm	150 mm	M16	10
55461	100 x 100 mm	150 mm	M16	10
55462	150 x 150 mm	150 mm	M24	10

BAMBUSOVÉ ZÁSTENY A TIENIACE TKANINY

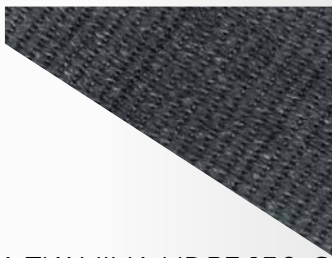
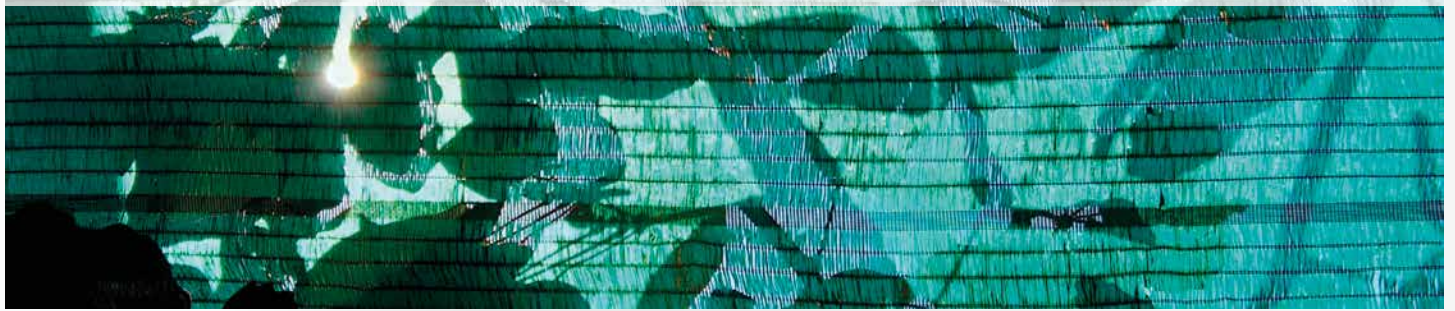
TIENIACA TKANINA HDPE 150 G / M² ANTRACIT

* tienenie 85%

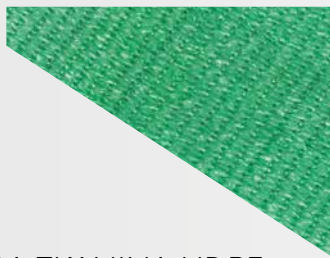

Č.p.	specifikace	
45496	1 x 10 m	1
45497	1,5 x 10 m	1
45498	1,8 x 10 m	1
45499	2 x 10 m	1

TIENIACA TKANINA HDPE 150 G / M²

* tienenie 85%

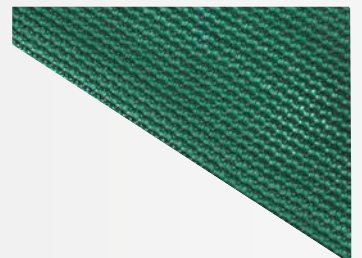

Č.p.	specifikace	
45460	1 x 10 m	1
45461	1,5 x 10 m	1
45463	1,8 x 10 m	1
45462	2 x 10 m	1

TIENIACA TKANINA HDPE 220 G / M²

* tienenie 95%

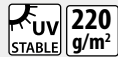

Č.p.	specifikace	
45465	1 x 10 m	1
45466	1,5 x 10 m	1
45467	2 x 10 m	1

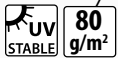
TIENIACA TKANINA HDPE 80 G / M²

Č.p.	specifikace	
45450	1 x 10 m	1
45451	1,5 x 10 m	1
45453	1,8 x 10 m	1
45452	2 x 10 m	1

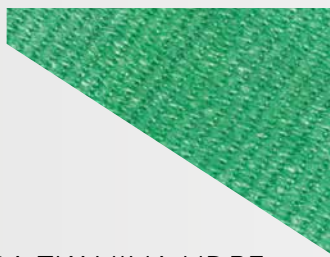
TIENIACA TKANINA HDPE 150 G / M²

* tienenie 85%



Č.p.	specifikace	
45480	1,5 x 50 m	1

TIENIACA TKANINA HDPE 220 G / M²

* tienenie 95%



Č.p.	specifikace	
45485	1,5 x 50 m	1

NEW



PÁSKY VÁZACÍ ZELENÉ

· EN 50146
· nylon

50x

Č.p.	specifikace	
23875	120 mm 4,8 mm	1



SPONA TIENIACEJ TKANINY

20x

Č.p.	specifikace	
45470		1



GRILOVANIE



SADA GRILOVACIEHO NÁRADIA

INOX 18x

Č.p. specifikace
43077



6



SADA GRILOVACIEHO NÁRADIA

INOX 3x

Č.p. specifikace
43071 380 mm



16



GRILOVACIE KLIŠŤE

INOX

Č.p. specifikace
43072 360 mm



25



GRILOVACIA TÁČKA

4x

Č.p. specifikace
43050 300 x 200 mm

50

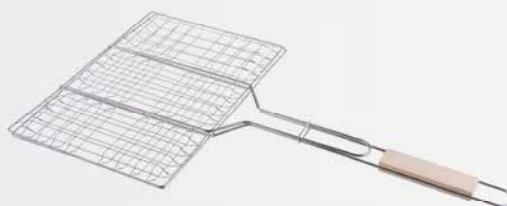
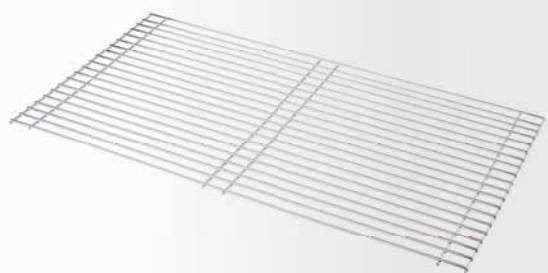

GRILOVACÍ ROŠT

Č.p.	specifikace	
43058	58 x 30 mm	20
43060	60 x 40 mm	20
43068	68 x 40 mm	16

OPEKACIA MRIEŽKA

Č.p.	specifikace	
43084	330 x 290 mm	50

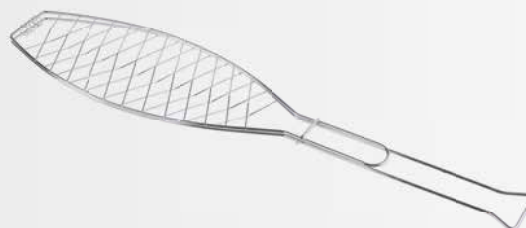

OPEKAČ RÝB

Č.p.	specifikace	
43082	280 x 276 mm	50

OPEKAČ RÝB

Č.p.	specifikace	
43083	360 x 130 mm	12

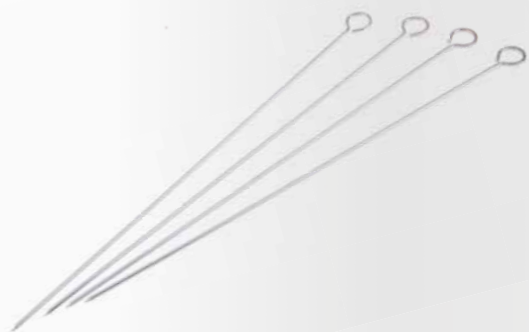

ŠAŠLÍKOVÉ IHLICE

4x

Č.p.	specifikace	
43086	Ø 3 x 380 mm	80

GRILOVACIA VIDLICA

· grilovacia vidlica s hygienickým atestom

Č.p.	specifikace	
43097	100 cm	100



GRILOVACÍ MOTOR 230V



Č.p. specifikace
43090



24



GRILOVACÍ MOTORČEK BATÉRIOVÝ
· batéria typ D



Č.p. specifikace
43089

48



KEFA NA ČISTENIE 2 V 1

Č.p. specifikace
43098 30 cm

10



KEFA 3 V 1

Č.p. specifikace
43099

40



MECHANICKÉ DÚCHADLO

Č.p. specifikace
43087



1



400

ZÁMKY VISAČE A ZÁMKY
NA BICYKLE

404

POKLADNE A POŠTOVÉ
SCHRÁNKY

406

UPÍNACIE POPRUHY



409

POVRAZY, MOTÚZY A
VIAZACIE PÁSKY

411

TAVNÉ PIŠTOLE



413

DRŽIAKY A NOSIČE

415

ČISTIČE ODPADU



417

DOMÁCE POTREBY



418

SVETLÁ



421

PAPIEROVÉ PREZENTAČNÉ
STOJANY



422

REGÁLOVÝ SYSTÉM SU-5



426

MURÁRSKE NÁRADIE
KUBALA

ŽELEZIARSKY TOVAR **398 - 431**



ZÁMKY

**FESTA**TREZOR
S ELEKTRONICKÝM ZÁMKOM

4x AA

- typ zámku: elektronický, mechanický
- bezpečnostný kľúč
- rozmery 350x250x250mm
- hmotnosť 10kg

 Č.p. špecifikácia
 23270

1

**FESTA**

VLOŽKA ZÁMKU MOSADZNÁ

3x

 Č.p. špecifikácia
 23001 65 mm · 175 g

10

FESTA

VLOŽKA ZÁMKU POMOSADZENÁ

3x

 Č.p. špecifikácia
 23000 65 mm · 75 g

15



FESTA

ZÁMOK VISIACI



Č.p.	špecifikácia		Č.p.	špecifikácia	
23261	25 mm	6	23264	45 mm	6
23262	32 mm	12	23265	52 mm	12
23263	38 mm	6	23266	63 mm	6

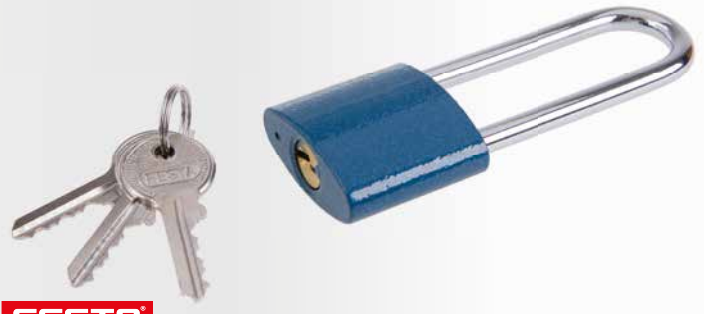

FESTA

ZÁMOK VISIACI PREDĹŽENÝ



Č.p.	špecifikácia		Č.p.	špecifikácia	
23211	25 mm	12	23214	45 mm	6
23212	32 mm	12	23215	52 mm	6
23213	38 mm	6			



FESTA

ZÁMOK VISIACI MOSADZNÝ
POPLASTOVANÝ



Č.p.	špecifikácia	
23310	30 mm	10
23311	40 mm	10
23312	50 mm	6



FESTA

ZÁMOK MOSADZNÝ ZOSILNENÝ



Č.p.	špecifikácia		Č.p.	špecifikácia	
23125	25 mm	12	23140	40 mm	12
23130	30 mm	12	23150	50 mm	12
23135	35 mm	12	23160	60 mm	12



FESTA

ZÁMOK VISIACI



Č.p.	špecifikácia	
23274	60 mm	6
23275	70 mm	12



ZÁMOK VISIACI



Č.p.	špecifikácia		Č.p.	špecifikácia	
23220	25 mm	6	23240	40 mm	6
23225	30 mm	6	23250	50 mm	6
23232	32 mm	6	23260	60 mm	6



ZÁMOK POMOSADZENÝ



Č.p.	špecifikácia		Č.p.	špecifikácia	
23020	20 mm	12	23040	40 mm	12
23025	25 mm	12	23050	50 mm	12
23030	30 mm	12	23060	60 mm	12
23035	35 mm	12			

ZÁMOK POMOSADZENÝ PREDĽŽENÝ



Č.p.	špecifikácia	
23070	40 mm	12



ZÁMOK VISIACI



Č.p.	špecifikácia	
23010	50 mm	6

ZÁMOK VISIACI



Č.p.	špecifikácia	
23005	40 mm	6
23006	50 mm	6

FESTA

ZÁMOK NA BICYKEL S ČÍSELNÝM KÓDOM



Č.p.	špecifikácia	
23288	120 cm x Ø 10 mm	1

FESTA

ZÁMOK NA BICYKEL S ČÍSELNÝM KÓDOM



Č.p.	špecifikácia	
23287	65 cm x Ø 10 mm	1



FESTA

ZÁMOK NA BICYKEL S ÚCHYTM



Č.p.	špecifikácia	
23290	120 cm x Ø 8 mm	1
23291	150 cm x Ø 8 mm	20
23292	180 cm x Ø 8 mm	1



ZÁMOK NA BICYKEL S ÚCHYTM



Č.p.	špecifikácia	
23297	180 cm x Ø 8 mm	25



ZÁMOK NA BICYKEL



Č.p.	špecifikácia	
23282	55 cm x Ø 8 mm	50
23284	65 cm x Ø 8 mm	50



ZÁMOK VISACÍ S ČÍSELNÝM KÓDOM

Č.p.	
23281	20



FESTA

VISAČKY KE KLÚČOM

100x

· zosilnený krúžok

Č.p.	
23391	50



VISAČKY KE KLÚČOM

100x

Č.p.	
23390	1



PETLICA

Č.p.	špecifikácia	
51514	100 mm	25
51515	120 mm	25
51516	140 mm	25
51517	160 mm	25



ZÁSTRČ

Č.p.	špecifikácia	
51510	100 mm	12
51511	120 mm	12
51512	140 mm	12
51513	160 mm	12



POKLADNE A POŠTOVÉ
SCHRÁNKY



SCHRÁNKA NA KLÚČE



Č.p.	špecifikácia	
70140	250 x 180 x 80 mm - pre 48 kľúčov	12
70141	300 x 230 x 90 mm - pre 90 kľúčov	8



POKLADŇA



Č.p.	šírka	hĺbka	výška	
70120	125 mm	95 mm	60 mm	1



POKLADŇA



Č.p.	šírka	hĺbka	výška	
70121	152 mm	118 mm	80 mm	36



POKLADŇA



Č.p.	šírka	hĺbka	výška	
70122	200 mm	160 mm	90 mm	20



POKLADŇA



Č.p.	šírka	hĺbka	výška	
70123	250 mm	180 mm	90 mm	16



POKLADŇA



Č.p.	šírka	hĺbka	výška	
70124	300 mm	240 mm	90 mm	10



POKLADŇA



Č.p.	šírka	hĺbka	výška	
70125	370 mm	280 mm	90 mm	8



SCHRÁNKA POŠTOVÁ



Č.p.	barva	šírka	hlbka	výška	
70101	biela	290 mm	360 mm	105 mm	5
70100	hnedá	290 mm	360 mm	105 mm	5



SCHRÁNKA POŠTOVÁ



Č.p.	barva	šírka	hlbka	výška	
70102	biela	310 mm	260 mm	90 mm	10
70103	hnedá	310 mm	260 mm	90 mm	10



SCHRÁNKA POŠTOVÁ



Č.p.	barva	šírka	výška	hlbka	
70104	biela	310 mm	360 mm	90 mm	6
70105	hnedá	310 mm	360 mm	90 mm	5



SCHRÁNKA POŠTOVÁ



Č.p.	barva	šírka	hlbka	výška	
70108	biela	370 mm	134 mm	364 mm	5



SCHRÁNKA POŠTOVÁ



Č.p.	materiál	šírka	hlbka	výška	
70107	nerez	360 mm	100 mm	520 mm	6



SCHRÁNKA POŠTOVÁ



Č.p.	materiál	šírka	hlbka	výška	
70106	nerez	360 mm	100 mm	360 mm	5



SCHRÁNKA POŠTOVÁ



Č.p.	materiál	šírka	hlbka	výška	
70109	nerez	310 mm	90 mm	260 mm	6



SCHRÁNKA POŠTOVÁ



Č.p.	materiál	šírka	hlbka	výška	
70110	nerez	310 mm	90 mm	360 mm	6



UPÍNACIE POPRUHY



FESTA

POPURHY UPÍNACIE SAMONAVÍJACIE



2x



Č.p.	šírka	dĺžka	nosnosť	ks	
51070	18 mm	2 m	100 kg	2	12



FESTA

POPURH UPÍNACÍ SAMONAVÍJACÍ



Č.p.	šírka	dĺžka	nosnosť	ks	
51071	25 mm	3,5 m	300 kg	1	8



FESTA

POPURH UPÍNACÍ SAMONAVÍJACÍ



Č.p.	šírka	dĺžka	nosnosť	ks	
51072	35 mm	4 m	500 kg	1	6



FESTA

POPURHY UPÍNACIE



Č.p.	šírka	dĺžka	nosnosť	ks	
51040	25 mm	6 m	1000 kg	1	1
51041	35 mm	8 m	2000 kg	1	1
51042	35 mm	8 m	3000 kg	1	1
51043	50 mm	10 m	5000 kg	1	1



FESTA

POPURHY UPÍNACIE



2x



Č.p.	šírka	dĺžka	nosnosť	ks	
51060	25 mm	5 m	750 kg	2	5



FESTA

POPURH UPÍNACÍ



Č.p.	šírka	dĺžka	nosnosť	ks	
51065	50 mm	10 m	960 kg	1	6



FESTA

POPURH UPÍNACÍ



Č.p.	šírka	dĺžka	nosnosť	ks	
51026	75 mm	5 m	3000 kg	1	4

NEW

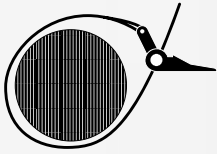

FESTA

POPRUH UPÍNACÍ



Č.p.	šírka	dĺžka	nosnosť	ks
51032	25 mm	5 m	500 kg	1

FESTA

POPRUH UPÍNACÍ



Č.p.	šírka	dĺžka	nosnosť	ks
51017	50 mm	6 m	480 kg	2
51018	50 mm	6 m	480 kg	1



PÁS UPÍNACÍ



Č.p.	šírka	dĺžka	špecifikácia	ks
51022	25 mm	5 m	s hákmi	40
51023	50 mm	5 m	s hákmi	12

FESTA

PÁS UPÍNACÍ

PE

• mäkká EVA podložka



Č.p.	šírka	dĺžka	ks
51046	38 mm	4 m	1



PÁS UPÍNACÍ



Č.p.	šírka	dĺžka	špecifikácia	ks
51030	50 mm	6 m	s hákmi	20
51034	50 mm	8 m	s hákmi	10



PÁS UPÍNACÍ

2x



Č.p.	šírka	dĺžka	ks
51020	25 mm	2,5 m	2



PÁS UPÍNACÍ

PE



Č.p.	šírka	dĺžka	ks
51045	25 mm	4 m	1



GUMA UPÍNACIA NASTAVITEĽNÁ

2x



Č.p.	dĺžka	Ø	ks
51013	1,2 m	8 mm	2



GUMA UPÍNACIA

2x

Č.p.	dĺžka	ks	
51008	1 m	2	25



GUMA UPÍNACIA S KARABÍNAMI



Č.p.	dĺžka	Ø	ks	
51009	1 m	10 mm	1	25



SADA UPÍNACÍCH POPRUHOV

8x

- 2 x 0,4 m
- 2 x 0,6 m
- 1 x 0,8 m
- 1 x 1,0 m

Č.p.	dĺžka	Ø	ks	
51011	1 m	8 mm	8	10



GUMY UPÍNACIE S HÁKMI

2x

Č.p.	dĺžka	Ø	ks	
51007	1 m	8 mm	2	25



GUMY UPÍNACIE - PAVÚK

Č.p.	dĺžka	Ø	špecifikácia	
51010	80 cm	8 mm	8 ramen	50



PRUŽNÁ UPEVŇOVACIA SIEŤ S HÁKMI

Č.p.	dĺžka	šírka	
51015	80 cm	120 cm	20



POPRUH ELASTICKÝ



Č.p.	dĺžka	Ø	
51036	20 m	8 mm	10
51037	20 m	10 mm	6



HÁČIKY NA UPÍNACIE GUMY

20x

Č.p.	dĺžka	
51038	8 mm	30



LANO PRIEMYSELNÉ



Č.p.	dĺžka	Ø	
50915	5 m	8 mm	1
50916	25 m	8 mm	1
50917	25 m	10 mm	1
50918	25 m	12 mm	1
50919	25 m	14 mm	1



KARABÍNA

ALU

MOQ
2

Č.p.	Ø	dĺžka	
51187	5 mm	50 mm	2
51200	6 mm	60 mm	2
51202	7 mm	70 mm	2

Č.p.	Ø	dĺžka	
51201	8 mm	80 mm	2
51203	10 mm	100 mm	2



LANO SILÓNOVÉ

Č.p.	dĺžka	Ø	
51050	50 m	8 mm	10
51051	50 m	10 mm	4



POVRÁZOK SILÓNOVÝ

Č.p.	dĺžka	Ø	
51055	80 m	1,5 mm	50
51056	50 m	2 mm	50
51057	20 m	4 mm	50



MOTOUZ POLYPROPYLEN

Č.p.	špecifikácia	
50905	80 g	80
50906	100 g	100
50907	200 g	50

ŠPAGÁT POLYPROPYLÉN

Č.p.	špecifikácia	
50909	500 g (250 m)	1
50910	1000 g (500 m)	1
50911	5000 g (2500 m)	1



ŠPAGÁT JUTA

Č.p.	špecifikácia	
50900	80 g (61 m)	1
50901	100 g (76 m)	1
50902	200 g (153 m)	1

ŠNÚRA VOSKOVANÁ



Č.p.	dĺžka	Ø	
50920	50 m	1 mm	80



NEW



PÁSKY VÁZACÍ ZELENÉ

· EN 50146
· nylon

50x

Č.p. / No.	Špecifikácia / Specification	
23875	120 mm 4,8 mm	1



PÁSKY VIAZACIE FAREBNÉ

100x

· EN 50146
· nylon

Č.p.	dĺžka	šírka	
23880	100 mm	2,5 mm	1
23882	150 mm	2,5 mm	1
23884	200 mm	3,6 mm	1



Ø 15 - 32 mm

PÁSKY VIAZACIE S ÚCHYTMOM

10x

UV STABLE

Č.p.	dĺžka	šírka	
23865	160 mm	7,5 mm	1



FESTA

PÁSKA NA SUCHÝ ZIPS 3 KS

3x

Č.p.	šírka	dĺžka	
37295	20 mm	150 mm	1
37296	20 mm	200 mm	1
37297	20 mm	250 mm	1



VIAZACIA PÁSKA, SUCHÝ ZIPS

Č.p.	špecifikácia	
45471	12 mm x 5 m	1



PÁSKY VIAZACIE BIELE

50x

· EN 50146
· nylon

Č.p.	dĺžka	šírka	
23850	120 mm	2,5 mm	1
23854	200 mm	3,6 mm	1
23856	250 mm	3,6 mm	1
23858	250 mm	4,8 mm	1
23860	300 mm	4,8 mm	1
23864	400 mm	4,8 mm	1
23866	500 mm	4,8 mm	1
23868	400 mm	7,6 mm	1
23870	500 mm	7,6 mm	1



PÁSKY VIAZACIE ČIERNE

50x

· EN 50146
· nylon

Č.p.	dĺžka	šírka	
23810	120 mm	2,5 mm	1
23814	200 mm	3,6 mm	1
23816	250 mm	3,6 mm	1
23818	250 mm	4,8 mm	1
23820	300 mm	4,8 mm	1
23824	400 mm	4,8 mm	1
23826	500 mm	4,8 mm	1
23828	400 mm	7,6 mm	1
23830	500 mm	7,6 mm	1





FESTA

PIŠTOĽ TAVNÁ - BEZDRÔTOVÁ



Č.p.	špecifikácia		
89975	80 W 230 V	Ø tavné tyčinky 11,2 mm	20



PIŠTOĽ TAVNÁ



Č.p.	špecifikácia		
89973	60 W 230 V	Ø tavné tyčinky 11,2 mm	20



PIŠTOĽ TAVNÁ



Č.p.	špecifikácia		
89970	15 W 230 V	Ø tavné tyčinky 7,2 mm	25



TYČINKY DO TAVNEJ PIŠTOĽE - ČÍRE

Č.p.	Ø tyčinky	dĺžka	počet ks v balení	
89985	11,2 mm	200 mm	10	50
89987	11,2 mm	200 mm	1 kg	25



TYČINKY DO TAVNEJ PIŠTOĽE - ČÍRE

Č.p.	Ø tyčinky	dĺžka	počet ks v balení	
89980	7,2 mm	100 mm	12	100
89988	7,2 mm	100 mm	1 kg	25



TYČINKY DO TAVNEJ PIŠTOĽE - FAREBNÉ

Č.p.	Ø tyčinky	dĺžka	počet ks v balení	
89990	11,2 mm	200 mm	10	50



TYČINKY DO TAVNEJ PIŠTOĽE - FAREBNÉ

Č.p.	Ø tyčinky	dĺžka	počet ks v balení	
89989	7,2 mm	100 mm	12	100

**FESTA****PIŠTOĽ HORKOVZDUŠNÁ
S REGULACÍU TEPLoty**

napätie / frekvencia	230V / 50Hz
príkion	2000W
poloha spínača	0 - I (350°C) - II (600°C)
príslušenstvo	nerezové nadstavce - 4 ks



Č.p. špecifikácia
35320 2000 W

5

FESTA**PIŠTOĽ TEPLOVZDUŠNÁ
S REGULACÍU TEPLoty A PRÚDU VZDUCHU**

napätie / frekvencia	230V / 50Hz
príkion	2000W
poloha spínača	0 - I (50°C) - II (50 - 600°C)
prúd vzduchu	250 - 500 l/min.
príslušenstvo	nerezové nadstavce - 4 ks
	· digitálny display



Č.p. špecifikácia
35322 2000 W

5

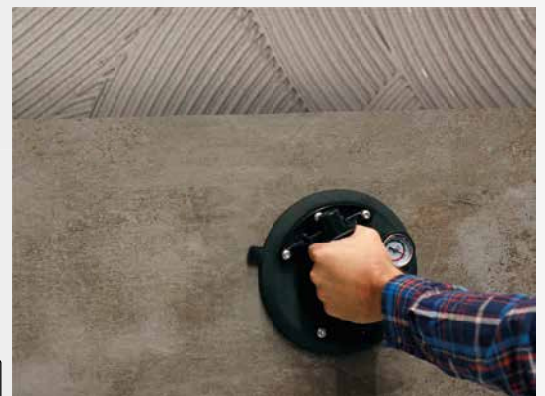
NEW**FESTA****DRŽIAK NA DLAŽBU
S INDIKÁTOROM PODTLAKU**

drsne a štruktúrované povrchy

Č.p. špecifikácia
36325 max. 220 kg



1



FESTA

SKLENÁRSKY DRŽIAK

poloha	max. nosnosť
horizontálna poloha	50 kg
vertikálna poloha	50 kg

ALU

Č.p.	špecifikácia
36314	jednoduchý



20

SKLENÁRSKY DRŽIAK

Č.p.	špecifikácia
36305	jednoduchý



60



FESTA

SKLENÁRSKY DRŽIAK

poloha	max. nosnosť
horizontálna poloha	80 kg
vertikálna poloha	100 kg

ALU

Č.p.	špecifikácia
36313	dvojitý



20

SKLENÁRSKY DRŽIAK

Č.p.	špecifikácia
36306	dvojitý



20



FESTA

SKLENÁRSKY DRŽIAK

poloha	max. nosnosť
horizontálna poloha	120 kg
vertikálna poloha	150 kg

ALU

Č.p.	špecifikácia
36318	trojitý



10

SKLENÁRSKY DRŽIAK

poloha	max. nosnosť
horizontálna poloha	80 kg
vertikálna poloha	100 kg

Č.p.	špecifikácia
36319	trojitý



10



MINCIAR ANALÓGOVÝ

Č.p.	maximálna nosnosť
24260	50 kg



10

MINCIAR

Č.p.	maximálna nosnosť	
24212	12,5 kg	48
24225	25 kg	6
24250	50 kg	6
24255	100 kg	6
24258	150 kg	6



PINZETA S LED SVETLOM



Č.p.	špecifikácia
50005	95 mm



8



SADA PINZIET NEREZ

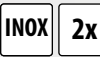

Č.p.	špecifikácia
50004	



1

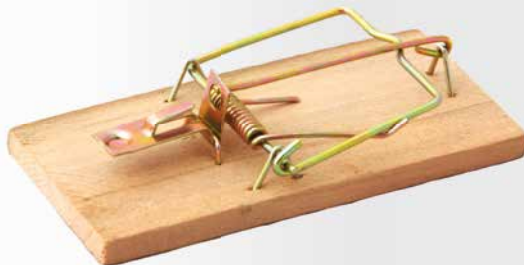

PASCA NA MYŠI

2x

Č.p.	špecifikácia
70221	90 x 45 mm drevená



1



PASCA NA MYŠI

2x

Č.p.	špecifikácia
70220	97 x 47 mm plastová



48

NEW



KLÚČ NA ODVZDUŠŇOVANIE RADIÁTOROV S NÁDOBOU



Č.p.	špecifikácia
17459	50 ml

1



Ø 15 mm

ČISTIČ ODPADU

· možnosť použitia s vŕtačkou

Č.p.	dĺžka	Ø
50014	6 m	6 mm



6



Ø 5mm

Ø 10mm

Ø 20mm

ČISTIČ ODPADU

Č.p.	dĺžka	Ø
50010	3 m	10
50011	5 m	5
50012	10 m	3
50013	15 m	4

ČISTIČ ODPADU

Č.p.	dĺžka	Ø
50009	3 m	5 mm



40



PUMPA NA ČISTENIE ODPADU

Č.p.	dĺžka	Ø
50015	385 mm	65 mm



30



ELEKTRIKÁRSKA PREŤAHOVACIA PRUŽINA

Č.p.	dĺžka	Ø
51181	8 m	5 mm
51182	10 m	5 mm



25

25

NEW

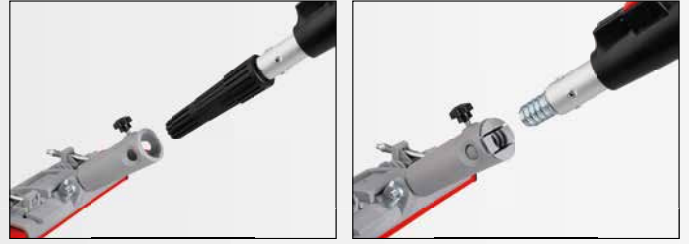

FESTA

TELESKOPICKÁ TYČ

· závit pre 31610, 34203

Č.p.	Špecifikácia	
52011	88 - 140 cm	1



TELESKOPICKÁ TYČ

ALU

Č.p.	dĺžka		
52010	120 cm	ALU	50
52012	240 cm	ALU	25



TELESKOPICKÁ TYČ

Č.p.	dĺžka		
52020	300 cm	ocel	10



TELESKOPICKÁ TYČ

Č.p.	dĺžka		
52030	240 cm	fiberglass	6

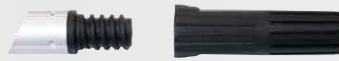

ZBERAČ ODPADKOV

· otočný o 90°

Č.p.	dĺžka	
61235	81 cm	12

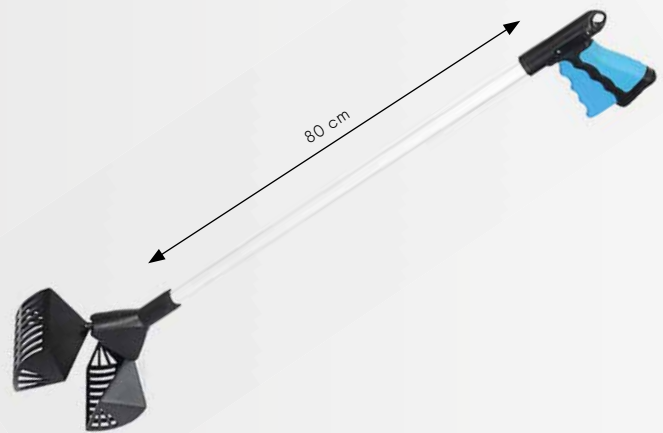

ZBERAČ ODPADKOV

· max. 4 kg

Č.p.	
61236	12



OLEJNIČKA

Č.p.	špecifikácia	
50020	300 ml	10

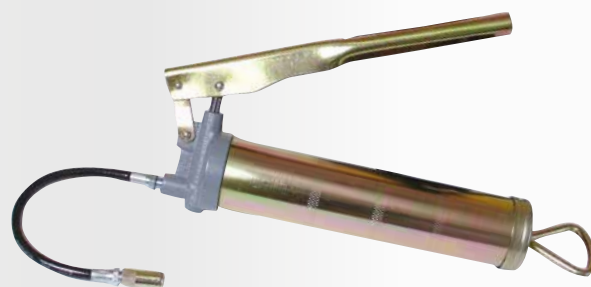

MAZNICA

- priame plnenie
- plnenie kartušou
- plnenie čerpadlom

Č.p.	špecifikácia	
50022	400 ml	20



BARELOVÁ PUMPA

Č.p.	špecifikácia	
50017		10



OLEJNIČKA

Č.p.	špecifikácia	
50019	90 ml	1



POVOĽOVAČ FILTROV

Č.p.	špecifikácia	
50021	60 x 140 mm	6



LIEVIK

Č.p.	špecifikácia	
50025	60 x 140 mm	50



HADICA PREČERPÁVACIA SO SAMONASÁVACÍM VENTILOM

Č.p.	dĺžka	Ø	
50026	180 cm	15 mm	24

SVIEDIDLÁ

**FESTA**

LED SVIETIDLO



Č.p.	špecifikácia
37645	200 mm 3 x AAA

MOQ
12

12

FESTA

LED ČELOVKA

váha	42 g
zdroj svetla	1 x 1 W white LED + 2x red LED
batérie	3 x AAA
rozmery	40 x 59 x 32 mm
doba svietenia	45 h
tok svetla	120 lumen
dosvit	60 m (100% battery)
režimy svietenia	4

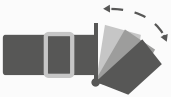

5 pozícií vyklopenie



Č.p.	špecifikácia
37641	120 lumen + červené svetlo



1

FESTA

LED ČELOVKA



Č.p.	špecifikácia
37640	120 lumen + červené svetlo



6



FESTA

LED SVIETIDLO

LED light 3x AA

Č.p.

37650



12



FESTA

LED SVIETIDLO

ALU LED light 2xAA 80 lumen

Č.p.

37630

špecifikácia

185 mm

2 x AA



20

LED SVIETIDLO

výkon	0,6 W
farebná teplota	700k
batérie	2xD
váha	138g
dĺžka dosvitu	30 m
svietivosť	50 lm



ALU LED light 2xAA 80 lumen

Č.p.

37621

špecifikácia

185 mm



6



KONZOLA BIELA

 MOQ
2

Č.p.	špecifikácia	
81100	100 x 75 mm	24
81101	125 x 100 mm	24
81102	150 x 125 mm	24
81103	200 x 150 mm	24
81104	250 x 200 mm	24
81105	300 x 250 mm	24
81106	350 x 300 mm	24



REGÁLOVÁ STOJKA JEDNODUCHÁ

Č.p.	špecifikácia	
81053	50 cm	10
81054	80 cm	10
81056	150 cm	10
81057	200 cm	10



REGÁLOVÝ HÁK JEDNODUCHÝ

Č.p.	špecifikácia	
81070	10 cm	10
81071	15 cm	10
81072	20 cm	10
81074	30 cm	10
81075	35 cm	10
81077	50 cm	10



PAPIEROVÝ PREZENTAČNÝ STOJAN FESTA

Č.p. špecifikácia
18601 60 x 40 x 175 cm - SK



PAPIEROVÝ PREZENTAČNÝ STOJAN FESTA POWER TOOLS

Č.p. špecifikácia
81603 60 x 40 x 175 cm



PAPIEROVÝ PREZENTAČNÝ STOJAN NA NIVELAČNÉ SYSTÉMY

Č.p. špecifikácia
37169 60 x 40 x 175 cm - SK



REGÁLOVÝ SYSTÉM SU - 5

RADI VÁM UROBÍME PONUKU NA POŽADOVANÚ
REGÁLOVÚ ZOSTAVU

STOJAN FESTA + PRÍSLUŠENSTVO

Č.p.	špecifikácia		
81011	stojan FESTA 220 x 100 cm	1	
81011A	stojan 81011 + samolepka AQUATIC	1	
81011F	stojan 81011 + samolepka FESTA CZ	1	
81011G	stojan 81011 + samolepka FESTA GB	1	
81011H	stojan 81011 + samolepka FESTA SK	1	
81011R	stojan 81011 + samolepka ROSA	1	
81012	polica FESTA 100 x 40 cm	8	
81013	háčik 10 cm	10	
81014	háčik 16 cm	10	
81015	háčik 20 cm	10	
81035	háčik s visačkou 20 cm	10	
81016	háčik 30 cm	10	
81036	háčik s visačkou 30 cm	10	
81022	kôš na hladítka - veľký, 50 cm	1	
81023	kôš na hladítka - malý, 40 cm	1	
81024	priečka ku košu - veľká, 50 cm	1	
81025	priečka ku košu - malá, 40 cm	1	



REGÁLOVÝ SYSTÉM SU - 5



RADI VÁM UROBÍME PONUKU NA POŽADOVANÚ REGÁLOVÚ ZOSTAVU

Č.p.	špecifikácia	
81200	Stojka 40/2400 mm kotvená	1
81201	Stojka 80/1108 mm	1
81202	Stojka 80/1208 mm	1
81203	Stojka 80/1408 mm	1
81204	Stojka 80/1608 mm	1
81205	Stojka 80/1808 mm	1
81206	Stojka 80/2000 mm	1
81207	Stojka 80/2108 mm	1
81208	Stojka 80/2208 mm	1
81209	Stojka 80/2308 mm	1
81210	Stojka 80/2408 mm	1
81211	Stojka 80/2600 mm	1
81212	Stojka 60/1000 mm	1
81213	Stojka 60/1208 mm	1
81214	Stojka 60/1408 mm	1
81215	Stojka 60/1608 mm	1
81216	Stojka 60/1808 mm	1
81217	Stojka 60/2108 mm	1
81218	Stojka 60/2208 mm	1
81225	Stojka 30/2108 mm predná	1
81486	Stojka 60/2000 mm	1
81219	Nástavec stojky 80x30/100mm	1
81220	Nástavec stojky 80x30/400 mm	1
81221	Nástavec stojky 80x30/600 mm	1
81222	Nástavec stojky 60x30/400 mm	1
81223	Stojka rohová 90st. 2100mm	1
81224	Stojka rohová 90st. 2200mm	1
81226	podpera 80	1
81227	podpera 60	1
81228	Spojka gondoly s regálom 80	1
81229	Kotevná lišta	1
81230	Kotevný hák	1
81231	kotvenie ľahké	1
81232	kotvenie vrchné	1
81233	Výplň 400	1
81234	Výplň 500	1
81235	Výplň 600	1
81236	Výplň 700	1
81237	Výplň 800	1
81238	Konzola nízka 200	1
81239	Konzola nízka 300	1
81240	Konzola nízka 400	1
81241	Konzola nízka 500	1
81242	Konzola vysoká 400	1
81243	Konzola vysoká 500	1
81244	Konzola vysoká 600	1
81245	Konzola vysoká 700	1
81246	Konzola nízka 300 dvojité	1
81247	Konzola nízka 400 dvojité	1
81248	Konzola nízka 300 dvojité	1
81251	Konzola RR 80	1
81249	Konzola vysoká dvojité 500	1
81250	Nosník vys. vitríny 400/2000	1
81252	Delítka korytovkej police	1
81253	Delítka nízke 300	1
81254	Delítka nízke 400	1
81255	Delítka nízke 500	1
81256	Delítka nízke 300 sklo	1
81257	Delítka nízke 400 sklo	1
81258	Delítka nízke 500 sklo	1
81259	Delítka vysoké 300 sklo	1
81262	Delítka vysoké 300 plexi	1
81263	Delítka vysoké 400 plexi	1
81264	Delítka vysoké 500 plexi	1
81260	Delítka vysoké 400 sklo	1
81261	Delítka vysoké 500 sklo	1
81265	Bok vys. vitríny 400/2000	1
81266	Bočnica zastrešenie RR 80	1
81267	Bočnica zásobníka 500mm	1
81268	Bočnica vitríny 500	1
81269	Nosník hornej vitríny 500	1
81271	Bočnica police nízka 300 plast	1
81272	Bočnica police nízka 400 plast	1
81273	Bočnica police nízka 500 plast	1
81274	Bočnica vysoká sklo 300/250	1
81275	Poistka Bočnica	1
81276	Bočnica vysoká sklo 500/250	1
81277	Bočnica police vysoká 400	1
81278	Bočnica police vysoká 500	1
81270	Nosník zastrešenie RR 80	1
81279	Nosník zastrešenie	1
81280	Bočnica zastrešenie ľavá	1
81281	Bočnica zastrešenie pravá	1
81282	Závesové rameno	1
81284	Rameno dvojité 400/10	1
81285	Rameno dvojité 300/8	1
81286	Rameno jednoduché 350	1
81287	Rameno jednoduché 500	1
81288	Rameno jednoduché 250	1
81289	Záves dvojité 100	1
81290	Záves dvojité 200	1
81291	Záves dvojité 300	1
81292	Záves 130 V	1

Č.p.	špecifikácia	
81293	Záves jednoduchý 100	1
81294	Záves jednoduchý 200	1
81295	Záves jednoduchý 300	1
81296	Jednoháčik s hrazdou 200	1
81297	Jednoháčik s hrazdou 300	1
81298	Zámok vitríny	1
81299	Delítka drôtené 360mm vysoké	1
81300	Delítka drôtené 460 mm vysoké	1
81301	Delítka drôtené 560 mm vysoké	1
81302	Delítka drôtené 560 mm nízke	1
81303	Konzola 300 dvojité L	1
81304	Konzola 300 dvojité P	1
81305	Konzola 400 dvojité L	1
81306	Konzola 400 dvojité P	1
81307	Konzola 500 dvojité L	1
81308	Konzola 500 dvojité P	1
81309	Polica polkruh 300	1
81310	Polica polkruh 400	1
81311	Polica polkruh 500	1
81312	Sokeľ polkruhu 500	1
81313	Čelo sokla polkruhu 500	1
81314	Držiak cenovky pol. 300 polkruh	1
81315	Držiak cenovky pol. 400 polkruh	1
81316	Držiak cenovky pol. 500 polkruh	1
81317	Polica polkruh 600	1
81318	Sokeľ polkruhu 600	1
81319	Čelo sokla polkruhu 600	1
81320	Cenovka P 7,5x5 cm	1
81321	Cenovka P 2,6x3,2 cm	1
81322	Cenovka P 5,0x4,0 cm	1
81323	Polica dierovaná 500/1000	1
81324	Spojnicia stojok 80, modul 1	1
81325	Zadný panel 10x100cm	1
81326	Zadný panel 20x100cm	1
81327	Zadný panel 40x100cm	1
81328	Zadný panel dier. 20x100 cm EUR	1
81329	Zadný panel dier. 40x100 cm EUR	1
81330	Kryt gondol 8x100cm	1
81331	Kryt gondol 6x100cm	1
81332	Nosník závesov 100cm	1
81333	Polica sklenená 985/300 vitrína	1
81334	Polica sklenená 985/400 vitrína	1
81335	Polica drevená 47/98,5	1
81336	Polica drôtená 1000/500	1
81337	Polica korytová 1000x500	1
81338	Polica 200/1000	1
81339	Polica 300/1000	1
81340	Polica 400/1000	1
81341	Polica 500/1000	1
81342	Polica 400/1000 RAL7015	1
81343	Polica 500/1000 RAL7015	1
81347	Rám vysokej vitríny 1000/400	1
81348	Sklo rámu vysokej vitríny 1000/400	1
81349	Zásuvková vložka regalová	1
81350	Podhlad kovovej police 500/100	1
81352	Čelná opora vysoká 1000 mm, sklo	1
81353	Čelná opora vysoká, plexi	1
81354	Čelná opora nízka 1000 mm, plast	1
81355	Cenovková lišta, 1000mm	1
81356	Hrebeň zásuvky regálu	1
81351	Hrebeň pre vysoké delítka, 1000	1
81357	Hrebeň, 1000 mm	1
81403	Hrebeň pre vysoké delítka, 1250 mm	1
81420	Hrebeň pre vysoké delítka, 625 mm	1
81358	Dvojdrážky dvierok vitríny	1
81359	Držiak cenovky, 1000mm	1
81360	Dvere vys. vitríny 1000/2000	1
81361	Čelo zastrešenia, 1000mm	1
81362	Doska zastrešenia, 1000mm	1
81363	Dvierka zásobníka	1
81364	Dvierka vitríny posuvné	1
81365	Zrkadlo vitríny	1
81366	Závesový rám, modul 1	1
81367	Závesová tyč	1
81370	Koš drôtený šikmý	1
81371	Pult s plnou doskou 1000mm	1
81372	Sokeľ pultu SU 5 1000mm	1
81373	Pult presklený 1000mm	1
81374	Pult s nerez doskou 1000mm	1
81375	Pult s plnou doskou 600mm	1
81376	Polica do pultu 600mm	1
81377	Pult presklený 600mm	1
81378	Polica do pultu 1000mm	1
81379	Polička pultu dlhá	1
81380	Segment pultu vysoký 90st.	1
81381	Dvojdrážka pultu 1000mm, pár	1
81382	Dvierka posuvné, pult 1000mm, pár	1
81383	Zásuvka pod dosku	1
81384	Polica drôtená RDE 1000 / 360mm	1
81385	Polica drôtená RDE 1000 / 460mm	1
81386	Polica drôtená RDE 1000 / 560mm	1
81387	Cenovková lišta RDE 1000 mm	1
81388	Zadný panel 100 / 1250mm plný	1

Č.p.	špecifikácia	
81389	Zadný panel 200 / 1250mm plný	1
81390	Zadný panel 400 / 1250mm plný	1
81391	Zadný panel 200 / 1250mm dierovaný	1
81393	Kryt gondoly 80 / 1250mm	1
81392	Zadný panel 400 / 1250mm dierovaný	1
81394	Kryt gondoly 60 / 1250mm	1
81395	Nosník závesov 1250mm	1
81396	Polica 200 / 1250mm	1
81439	Nosník závesov 1000 mm	1
81344	Polica 300/1000 zosilnená	1
81345	Polica 400/1000 zosilnená	1
81346	Polica 500/1000 zosilnená	1
81397	Polica 300 / 1250mm	1
81400	Polica 300 / 1250mm, zosilnená	1
81401	Polica 400 / 1250mm, zosilnená	1
81402	Polica 500 / 1250mm, zosilnená	1
81398	Polica 400 / 1250mm	1
81399	Polica 500 / 1250mm	1
81404	Čelná opora nízka 1250mm, plast biely	1
81405	Cenovková lišta, 1250mm	1
81406	hrebeň 1250mm	1
81407	Držiak cenovky, 1250mm	1
81408	Čelo zastrešenia, 1250mm	1
81409	Doska zastrešenia, 600x1250mm	1
81410	Zadný panel 100/625 plný	1
81411	Zadný panel 200/625 plný	1
81412	Zadný panel 400/625 plný	1
81413	Zadný panel 400/625 dierovaný	1
81414	Kryt gondol 80/650	1
81415	Kryt gondol 60/650	1
81416	Nosník závesov, modul 3	1
81432	Nosník závesov, 1330mm	1
81417	police 300/625	1
81418	police 400/625	1
81419	police 500/625	1
81421	Čelná opora nízka 625, plast biely	1
81422	Cenovková lišta 625mm	1
81423	hrebeň 625mm	1
81424	Držiak cenovky, 625mm	1
81425	Zadný panel 100/1330 plný	1
81457	Čelná opora nízka 200 plast	1
81426	Zadný panel 200/1330 plný	1
81427	Zadný panel 400/1330 plný	1
81428	Zadný panel 200/1330 dierovaný S	1
81429	Zadný panel 400/1330 dierovaný S	1
81430	Kryt gondol 80/1330	1
81431	Kryt gondol 60/1330	1
81433	police 300/1330	1
81434	police 400/1330	1
81435	police 500/1330	1
81436	Cenovková lišta, 1330 mm	1
81437	Hrebeň 1330 mm	1
81438	Držiak cenovky 1330 mm	1
81440	Polica drôtená - koš	1
81441	Zadný panel 100 kútový	1
81442	Zadný panel 400 kútový	1
81443	Čelo sokla kútové 500 / 1000mm	1
81444	Čelo sokla kútové 600 mm	1
81445	Zadný panel kútový 400mm dierovaný	1
81447	Polica 300 kútová	1
81448	Polica 400 kútová	1
81449	Polica 500 kútová	1
81450	Polica 600 kútová	1
81451	Držiak cenovky 300 kútový	1
81452	Držiak cenovky 400 kútový	1
81453	Držiak cenovky 500 kútový	1
81454	Lišta Cenovková 300 kútová	1
81455	Lišta Cenovková 400 kútová	1
81456	Lišta Cenovková 500 kútová	1
81458	Polica drôtená koš U 1000/400	1
81459	Polica drôtená koš U 1000/500	1
81460	Rohové čelo sokla 90st.	1
81461	Panel zadný rohový 100, stojka 60	1
81462	Panel zadný rohový 200, stojka 60	1
81463	Panel zadný rohový 400, stojka 80	1
81466	Panel zadný rohový 100, stojka 80	1
81467	Panel zadný rohový 400, stojka 60	1
81468	Polica rohová 90st. 400mm	1
81469	Polica rohová 90st. 500mm	1
81470	Držiak cenovky rohový 90st. 400mm	1
81471	Držiak cenovky rohový 90st. 500mm	1
81472	Cenovková lišta rohová 90st. 400mm	1
81473	Cenovková lišta rohová 90st. 500mm	1

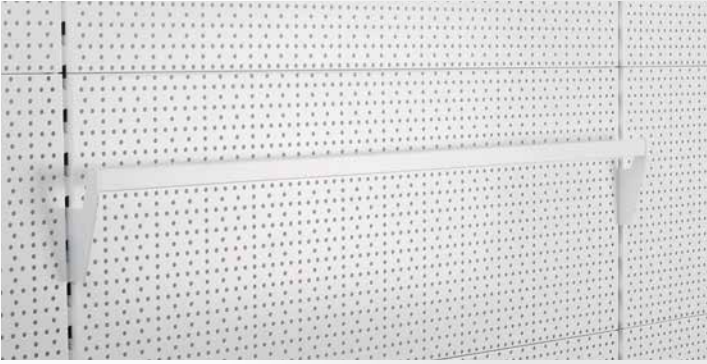

TRADE KONZOLA

kompatibilné so stojanom FESTA

Č.p.	špecifikácia	
81150	1000 × 50 × 135 mm	1

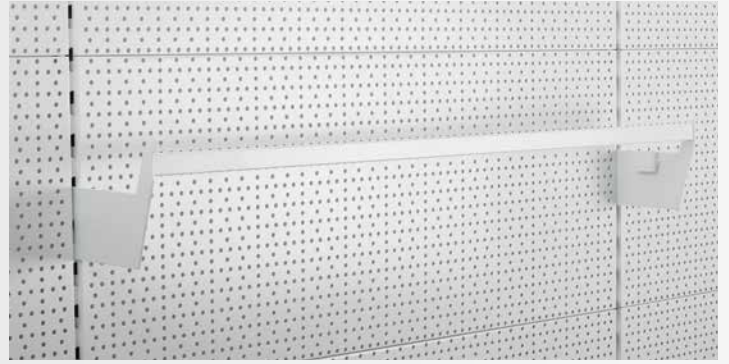

TRADE KONZOLA

kompatibilné so stojanom FESTA

Č.p.	špecifikácia	
81151	1000 × 150 × 135 mm	1

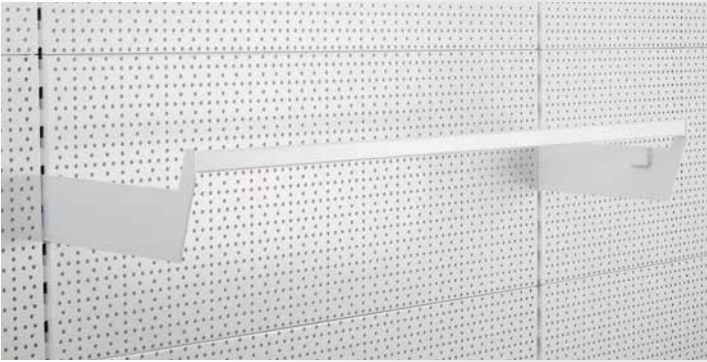

TRADE KONZOLA

kompatibilné so stojanom FESTA

Č.p.	špecifikácia	
81152	1000 × 350 × 135 mm	1

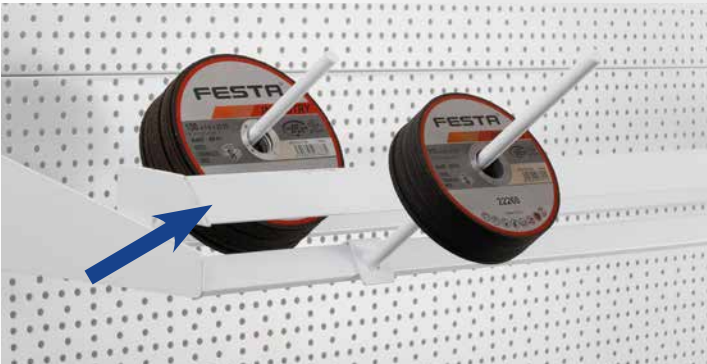
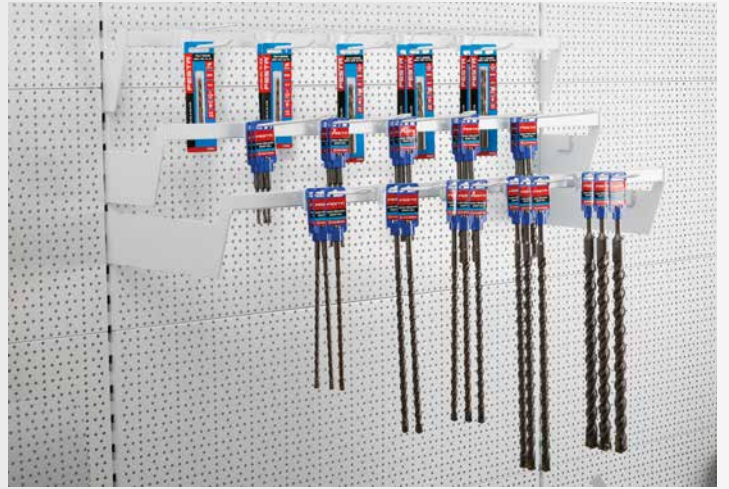

DRŽIAK CENOVKOVEJ LIŠTY

kompatibilné so stojanom FESTA

Č.p.	špecifikácia	
81155	1000 × 80 × 100 mm	1

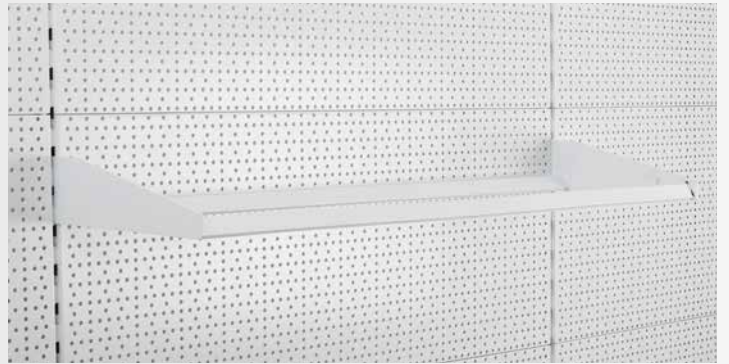

RÁM PRE REZNÉ KOTUČE

kompatibilné so stojanom FESTA

Č.p.	špecifikácia	
81170	1000 × 450 × 85 mm	1

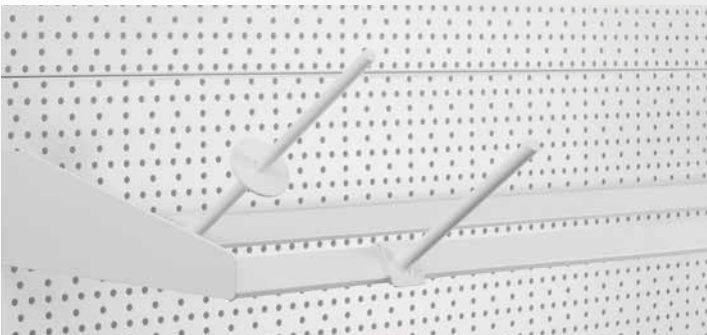

HÁK PRE REZNÉ KOTUČE

kompatibilné so stojanom FESTA

Č.p.	špecifikácia	
81186	150 mm	1
81185	250 mm	1



HÁK PRE AKU NÁRADIE

kompatibilné so stojanom FESTA

Č.p.	špecifikácia	
81189		1

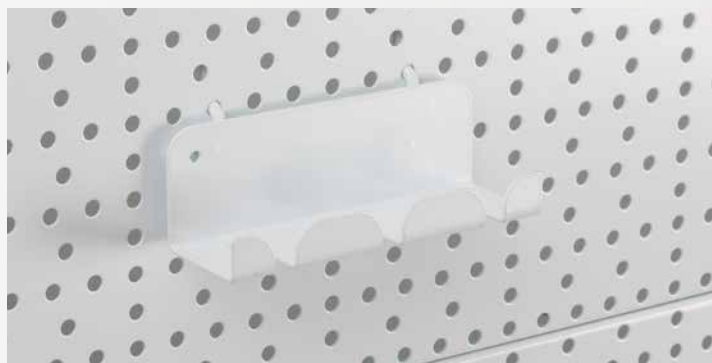

DRŽIAK NA PÍLY

kompatibilné so stojanom FESTA

Č.p.	špecifikácia	
81190		1



POLICE PRE KOTUČE

kompatibilné so stojanom FESTA

Č.p.	špecifikácia	
81191	220 x 220 x 200 mm	1

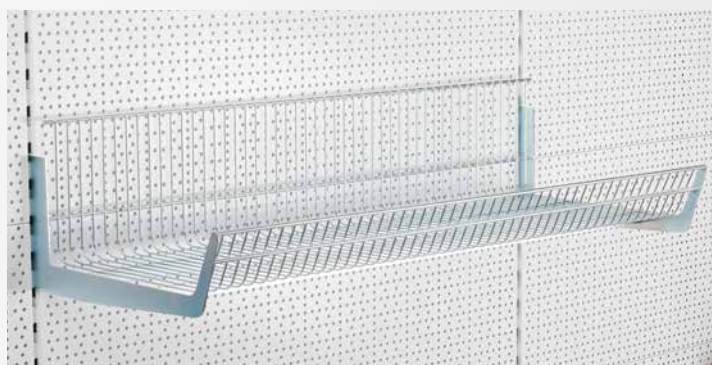

KOŠ ZÁVESNÝ

kompatibilné so stojanom FESTA

Č.p.	špecifikácia	
81160	1000 x 470 x 180 mm	1



DELÍTKO

kompatibilné so stojanom FESTA

Č.p.	špecifikácia	
81165	470 x 180 mm	1

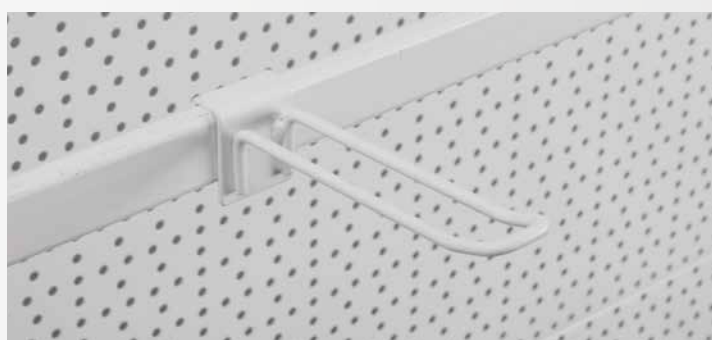

HÁK DVOJITÝ NA HRAZDU

kompatibilné so stojanom FESTA

Č.p.	špecifikácia	
81175	120 mm	1
81178	180 mm	1



HÁK JEDNODUCHÝ NA HRAZDU

kompatibilné so stojanom FESTA

Č.p.	špecifikácia	
81180	120 mm	1



Kubala
HLADÍTKO NEREZ

INOX

Č.p.	špecifikácia		
33100	130 x 270 mm	hladké, 2 zaoblené rohy	10



Kubala
HLADÍTKO NEREZ

INOX

Č.p.	špecifikácia		
33102	130 x 270 mm	hladké, G-1 rúčka	10



Kubala
HLADÍTKO NEREZ

INOX

Č.p.	špecifikácia		
33105	130 x 350 mm	hladké, G-8 rúčka	6



Kubala
HLADÍTKO NEREZ

INOX

Č.p.	špecifikácia		
33107	110 x 270 mm	rohové	10



Kubala
HLADÍTKO NEREZ

INOX

Č.p.	špecifikácia		
33110	130 x 270 mm	hladké, G-11 rúčka	10



Kubala
HLADÍTKO NEREZ

INOX

Č.p.	špecifikácia		
33112	130 x 270 mm	zub 6 x 6, G-11 rúčka	10
33113	130 x 270 mm	zub 8 x 8, G-11 rúčka	10
33114	130 x 270 mm	zub 10 x 10, G-11 rúčka	10



Kubala
HLADÍTKO NEREZ

INOX

Č.p.	špecifikácia		
33120	130 x 480 mm	hladké, G-12 rúčka	10



Kubala
HLADÍTKO NEREZ

INOX

Č.p.	špecifikácia		
33123	130 x 480 mm	zub 8 x 8, G-12 rúčka	10
33124	130 x 480 mm	zub 10 x 10, G-12 rúčka	10



Kubala

HLADÍTKO NEREZ OBLÉ ROHY

INOX

Č.p.	špecifikácia	
33127	130 x 480 mm 2 zaoblené rohy	10



Kubala

HLADÍTKO NEREZ " BENÁTSKE "

INOX

Č.p.	špecifikácia	
33131	80 x 200 mm G-1 rúčka	10
33132	75 x 95 x 240 mm trapézové G-1 rúčka	10



Kubala

HLADÍTKO NEREZ

INOX

Č.p.	špecifikácia	
33135	130 x 270 mm šikmé zuby 8 mm, G-1 rúčka	10



Kubala

HLADÍTKO NEREZ

INOX

Č.p.	špecifikácia	
33137	130 x 270 mm zub polkruhový, G-1 rúčka	10



Kubala

LYŽICA NEREZ VYMAZÁVACIA

INOX

Č.p.	špecifikácia	
33140	50 mm	20
33141	60 mm	20
33142	80 mm	20
33143	100 mm	20



Kubala

HLADÍTKO PLASTOVÉ ABS

INOX

Č.p.	špecifikácia	
33150	130 x 240 mm	12

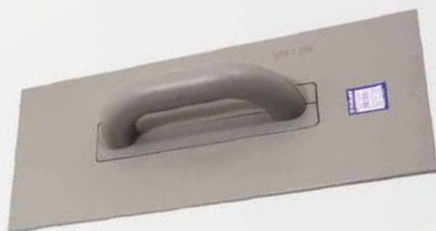

Kubala

HLADÍTKO PLASTOVÉ

INOX

Č.p.	špecifikácia	
33151	180 x 400 mm	1
33152	130 x 600 mm	1



Kubala

HLADÍTKO PLASTOVÉ

INOX

Č.p.	špecifikácia	
33154	130 x 270 mm G-17 rúčka	12

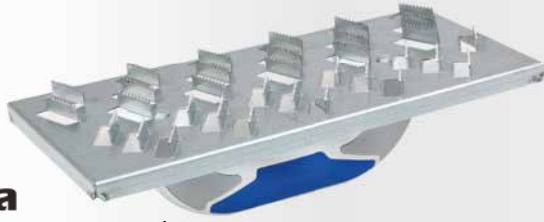

Kubala

ŠKRABÁK PLECHOVÝ
NA KAMENNŮ MINERÁLNŮ VLNU

Zn

Č.p.	špecifikácia	MOQ
32328	285 x 145 mm	2 10



Kubala

HLADÍTKO NA BRÚSNU MRIEŽKU

Č.p.	špecifikácia	MOQ
33160	105 x 210 mm s podkladovou gumou	2 20

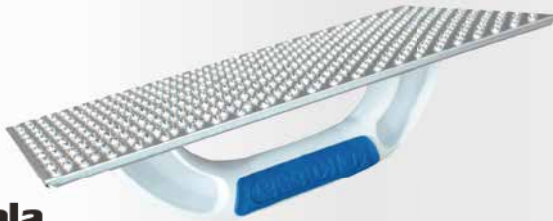

Kubala

HLADÍTKO BRÚSNE

INOX

Č.p.	špecifikácia	MOQ
33162	130 x 270 mm	2 20
33163	180 x 400 mm	10
33164	160 x 380 mm	10

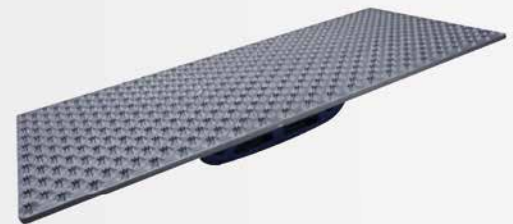

Kubala

HLADÍTKO BRÚSNE PLASTOVÉ

Č.p.	špecifikácia	MOQ
33165	165 x 365 mm	2 10



Kubala

HLADÍTKO BRÚSNE S OTVORMI

Č.p.	špecifikácia	MOQ
33169	160 x 380 mm dierkované, G-16 rúčka	2 10



Kubala

HLADÍTKO BRÚSNE

Č.p.	špecifikácia	MOQ
33167	130 x 270 mm G-17 rúčka	2 20
33168	160 x 380 mm G-17 rúčka	10
33170	180 x 400 mm G-17 rúčka	10



Kubala

STIERKA NEREZ

INOX

Č.p.	špecifikácia	
33200	40 mm	20
33201	60 mm	20
33202	80 mm	20
33203	100 mm	20



Kubala

STIERKA NEREZ

INOX

Č.p.	špecifikácia	
33205	130 x 90 mm	20



Kubala

STIERKA NEREZ

INOX

Č.p.	špecifikácia	
33206	130 x 37 mm	20



Kubala

STIERKA NEREZ

INOX

Č.p.	špecifikácia	
33207	150 mm s bitom PH2	30



Kubala

STIERKA NEREZ

INOX

Č.p.	špecifikácia	
33208	350 x 90 mm	10



Kubala

STIERKA NEREZ

INOX

Č.p.	špecifikácia	
33210	335 x 37 mm	20



Kubala

STIERKA NEREZ

INOX

Č.p.	špecifikácia	
33210	150 mm G-15 rúčka	10
33211	250 mm G-15 rúčka	10
33212	350 mm G-15 rúčka	10



Kubala

STIERKA NEREZ FASÁDNÁ

INOX

Č.p.	špecifikácia	
33215	600 mm AL uchytenie, G-14 rúčka	10



Kubala
STIERKA PLASTOVÁ

Č.p.	špecifikácia	
33220	145 mm s gumou	10



Kubala
STIERKA PLASTOVÁ

Č.p.	špecifikácia	
33221	245 mm s gumou	10



Kubala
HLADÍTKO PLASTOVÉ, GUMA POD UHLOM

Č.p.	špecifikácia	
33155	95 x 240 mm s podkladovou gumou	5



Kubala
SÚPRAVA PRE OBKLADAČOV

Č.p.	špecifikácia	
33250		1



Kubala
VEDRO OBDĽŽNIKOVÉ

Č.p.	špecifikácia	
33254	16 l mriežka, kolieska	1
33255	20 l mriežka, kolieska	1



Kubala
SÚPRAVA PRE OBKLADAČOV MINI

Č.p.	špecifikácia	
33252		1



Kubala
DIELY PRE VYMÝVACIE SADY

Č.p.	špecifikácia	
33257	trojité valčeky do vedra	1



Kubala
DIELY PRE VYMÝVACIE SADY

Č.p.	špecifikácia	
33256	valčeky do vedra	1
33258	valčeky do vedra	1



Kubala
DIŠŤANČNÉ SPONY SMART LEVEL

· nivelačné klinky 37175, 33246

100x

Č.p.	špecifikácia	
33247	1 mm	15
33248	2 mm	15
33249	3 mm	15

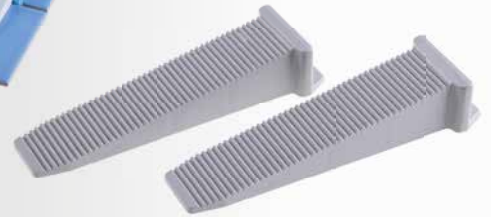

Kubala
NIVELAČNÉ KLINKY

50x

Č.p.	špecifikácia	
33246	Smart Level	15



Kubala
NABERAČKA PLASTOVÁ

Č.p.	špecifikácia	
33270	175 mm	20



Kubala
MISKA NA SADRU GUMOVÁ

Č.p.	špecifikácia	
33275	0,5 l	20



Kubala
STIERKA GUMOVÁ

Č.p.	špecifikácia	
33280	200 mm	10
37010	135 mm	20



Kubala
NIVELAČNÝ VALČEK

Č.p.	špecifikácia	
33289	85 x 230 mm	15



Kubala
ŠKRABÁK NA FARBY CIDLINKA

Č.p.	špecifikácia	
33285	60 mm	1
33286	náhradné ostrie 60 mm	1



Kubala
VRTÁK DO PÓROBETÓNU

Č.p.	špecifikácia	
33291	60 mm	1
33292	80 mm	1
33293	120 mm	1



Kubala
POKOSNICA PLASTOVÁ

Č.p.	špecifikácia	
33298	250 x 80 x 50 mm	1
33299	300 x 115 x 65 mm	1





AUTODOPLNKY 432 - 443





HYDRAULICKÝ ZDVIHÁK, JEDNOPIESTOVÝ

- Nastaviteľný skrutku umožňuje jemné nastavenie výšky a maximálny zdvih
- Dvojitý bezpečnostný prepúšťací ventil
- Veľká vrúbkovaná dosadacia plocha pre bezpečné podopretie
- Široká základňa zaisťuje stabilitu a odolnosť
- Všetky silne namáhané body sú zosilnené pre zvýšenie odolnosti a životnosti



Č.p.	špecifikácia	nosnosť	min. výška	zdvih	jemné nastavenie výšky	rozmery základny	váha	
26800	hydraulický zdvihák	2 000 kg	181mm	116 mm	48 mm	88 x 92 mm	2,6 kg	1
26801	hydraulický zdvihák	3 000 kg	194 mm	118 mm	60 mm	92 x 100 mm	3,3 kg	1
26802	hydraulický zdvihák	5 000 kg	216 mm	127 mm	70 mm	96 x 112 mm	4,5 kg	1
26803	hydraulický zdvihák	8 000 kg	230 mm	147 mm	80 mm	103 x 118 mm	5,7 kg	1
26804	hydraulický zdvihák	10 000 kg	230 mm	150 mm	80 mm	110 x 123 mm	6,8 kg	1
26805	hydraulický zdvihák	12 000 kg	230 mm	155 mm	80 mm	116 x 134 mm	7,3 kg	1
26806	hydraulický zdvihák	15 000 kg	230 mm	150 mm	80 mm	133 x 136 mm	8,4 kg	1
26807	hydraulický zdvihák	20 000 kg	242 mm	150 mm	60 mm	144 x 152 mm	11 kg	1

HYDRAULICKÝ ZDVIHÁK, DVOJPIESTOVÝ

- Nastaviteľný skrutku umožňuje jemné nastavenie výšky a maximálny zdvih.
- Dvojitý bezpečnostný prepúšťací ventil.
- Veľká vrúbkovaná dosadacia plocha pre bezpečné podopretie.
- Široká základňa zaisťuje stabilitu a odolnosť.
- Všetky silne namáhané body sú zosilnené pre zvýšenie odolnosti a životnosti.



Č.p.	špecifikácia	nosnosť	min. výška	zdvih	jemné nastavenie výšky	váha	
26815	hydraulický zdvihák teleskopický	2 000 kg	150 mm	160 mm	60 mm	4,7 kg	1
26816	hydraulický zdvihák teleskopický	4 000 kg	160 mm	170 mm	60 mm	6,4 kg	1
26817	hydraulický zdvihák teleskopický	6 000 kg	215 mm	270 mm	-	8,9 kg	1
26819	hydraulický zdvihák teleskopický	10 000 kg	228 mm	284 mm	89 mm	10,2 kg	1



NOŽNICOVÝ ZDVIHÁK



Č.p.	špecifikácia	nosnosť	min výška	max výška	váha	
26844	nožnicový zdvihák	1 000 kg	88 mm	380 mm	2,5 kg	1
26845	nožnicový zdvihák	2 000 kg	120 mm	395 mm	3,5 kg	1



26820



26826



26824



26825

HYDRAULICKÝ POJAZDNÝ ZDVIHÁK



Č.p.	špecifikácia	nosnosť	min výška	max výška	váha	
26820	hydraul. zdvihák pojazdný, prenosný	2 000 kg	130 mm	345 mm	9,6 kg	1
26826	hydraul. zdvihák pojazdný, nízky profil, 360 ° otoč. madlo	2 000 kg	89 mm	359 mm	14,2 kg	1
26824	hydraul. zdvihák pojazdný, dielenský, nožný pedál	3 000 kg	145 mm	500 mm	37,2 kg	1
26825	hydraul. zdvihák pojazdný, dielenský, nízky profil, profi	2 500 kg	85 mm	455 mm	34,8 kg	1



HYDRAULICKÝ POJAZDNÝ ZDVIHÁK + PODPERY

· ovládacia tyč otočná o 360°



Č.p.	špecifikácia	nosnosť	min výška	max výška	váha	
26829	hydraulický zdvihák pojazdný	2 000 kg	130 mm	350 mm	10,5 kg	1
	2ks nastaviteľné podpery	2 000 kg	275 mm	420 mm	5 kg (pair)	



NASTAVITEĽNÁ PODPERA

- 1ks = 1pár
- Hrebeň pre presné nastavenie výšky s dvojitým zaistením
- Masívna oceľová rukoväť
- Veľká dosadacia plocha, silná konštrukcia rámu
- Liatinová podperná časť



Č.p.	špecifikácia	nosnosť	min výška	max výška	váha	
26857	nastaviteľná podpera - pár; s poistkou	2 000 kg	275 mm	420 mm	4,8 kg	1
26858	nastaviteľná podpera - pár; s poistkou	3 000 kg	285 mm	425 mm	6,3 kg	1
26859	nastaviteľná podpera - pár; s poistkou	6 000 kg	393 mm	593 mm	13 kg	1
26853	nastaviteľná podpera - pár	12 000 kg	465 mm	715 mm	28 kg	1



HYDRAULICKÝ ŽERIAVOVÝ ZDVIHÁK, SKLADACÍ

- Pre zdvíhanie a ukladanie agregátov pri ich montáži a demontáži
- Nosné rameno má niekoľko polôh vysunutia a podľa toho sa tiež riadi nosnosť žerjavu
- Konštrukcia v sklopnom prevedení umožňuje, aby žerjav zaberá mimo prevádzky malý priestor



Č.p.	špecifikácia	nosnosť	min výška	max výška	váha	
26862	hydraulický žeriový zdvihák, skladací	2 000 kg	0	2360 mm	88 kg	1



OPORNÝ DRŽIAK MOTORY

- Kyvadlové zavesenie ramena držiaka v závislosti od sklonu kapoty, zaisťuje vždy vyvážené a stabilné upevnenie motora



Č.p.	špecifikácia	nosnosť	dĺžka	rozsah	váha	
26871	vyrovnávací záves motora	500 kg	1500 mm	150 mm	20,3 kg	1



HYDRAULICKÝ ZDVIHÁK PREVODOVKY

- Jednoduchá montáž a demontáž agregátov (motorov, prevodoviek, náprav a pod.)



Č.p.	špecifikácia	nosnosť	dĺžka	rozsah	váha	
26880	hydraulický zdvihák prevodovky	500 kg	1100 mm	1900 mm	30,0 kg	1
26881	nástavec pre automatické prevodovky	500 kg	1100 mm	1900 mm	15,0 kg	1



ROZPÍNACÍ SÚPRAVA

- Hydraulické zariadenie pre opravovanie karosérií vozidiel
- Skladá sa z hydraulického rozpínacieho valca a 14-tich dielov príslušenstvo
- Široký rozsah využitia pri opravách karosérií osobných, dodávkových a nákladných vozidiel predovšetkým v miestach, kde nie je možnosť napojenia na zdroje energie
- Zariadenie možno využiť pre rozpínanie, stláčanie, zdvíhanie a natiahovanie vo vertikálnych i horizontálnych smeroch
- Jednoduché prenášanie v plastovom kufrí



Č.p.	špecifikácia	nosnosť	hydraulický zdvih	váha	
26886	rozpínací súprava	4 000 kg	125 mm	17,0 kg	1
26888	rozpínací súprava	10 000 kg	135 mm	32,0 kg	1



26920



26921



26922

STOJAN NA MOTOR

- Pojazdny stojan pre upevnenie a prácu na demontovaných motoroch
- Univerzálna upínacia jednotka umožňuje ako upnutie motora, tak jeho otáčania



Č.p.	špecifikácia	nosnosť	váha	
26920	stojan na motor polohovateľný, pojazdny	450 kg	20 kg	1
26921	stojan na motor polohovateľný, pojazdny	560 kg	27 kg	1
26922	stojan na motor polohovateľný, pojazdny, skladací	675 kg	35 kg	1

RUČNÝ LANOVÝ NAVIJAK

Zn

- Kvalitný pozinkovaný navijak s odolným oceľovým lanom



Č.p.	špecifikácia	Ø Priemer lana	max. záťaž	dĺžka lana	
26705	ručný lanový navijak	4,0mm	450 kg	10 m	1
26706	ručný lanový navijak	5,0mm	900 kg	10 m	1
26707	ručný lanový navijak	6,0mm	1350 kg	10 m	1
26720	ručný lanový navijak	4,0mm	300 kg	10 m	1
26721	ručný lanový navijak	4,0mm	500 kg	10 m	1
26722	ručný lanový navijak	5,0mm	800 kg	10 m	1

REŤAZOVÝ ZDVIHÁK



Č.p.	špecifikácia	Záťaž	min. výška	zdvih	Počet kladiek	Hrúbka reťaze	váha	
26700	reťazový zdvihák	500 kg	280 mm	3 000 mm	1	6 mm	7,5 kg	1
26701	reťazový zdvihák	1 000 kg	300 mm	3 000 mm	1	6 mm	9 kg	1
26702	reťazový zdvihák	2 000 kg	380 mm	3 000 mm	2	6 mm	12 kg	1



STLAČOVACIE PRUŽÍN

· 26897 - pre demontáž pružín typu mcpherson priamo na vozidle.

· 26943 - pre demontáž pružín typu mcpherson mimo vozidla masívne oceľové profily pre väčšiu stabilitu.

Č.p.	špecifikácia	Záťaž	Ø stlač. pružiny	Rozpätie stlačenie	váha	
26897	stlačovač pružín prenosný	1 000 kg	100-200 mm	150 mm	24,5 kg	1
26943	stlačovač pružín	1 000 kg	400 mm	210-570 mm	35 kg	1



HYDRAULICKÝ LIS

Č.p.	špecifikácia	rozsah	max. záťaž	váha	
26940	hydraulický lis	0 - 610 mm	12 000 kg	43 kg	1
26941	hydraulický lis	0 - 880 mm	20 000 kg	75 kg	1

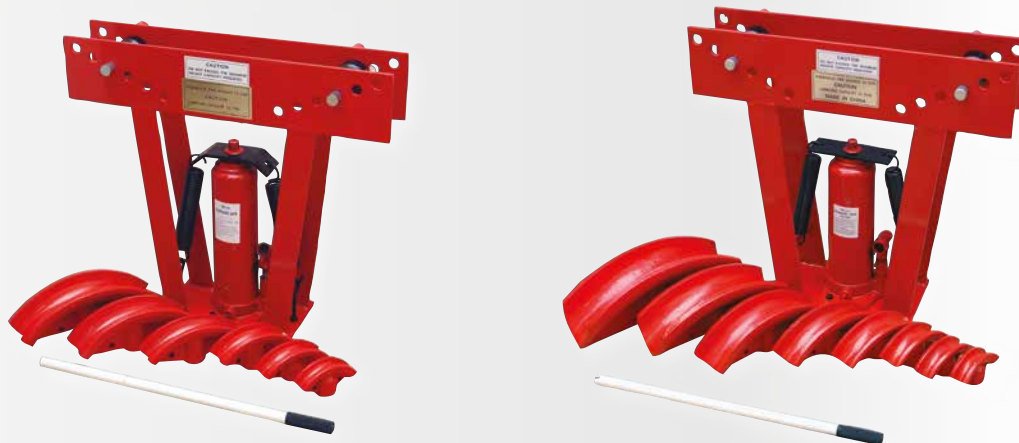

HYDRAULICKÁ OHÝBAČKA RÚROK

Č.p.	špecifikácia	Záťaž	zdvih	Ohýbacie kolena	váha	
26895		12 000 kg	232 mm	1 2", 3 4", 1", 1-1 4", 1-1 2", 2"	36 kg	1
26896		16 000 kg	238 mm	1 2", 3 4", 1", 1-1 4", 1-1 2", 2", 2-1 2", 3"	65 kg	1



HYDRAULICKÝ VALEC



Č.p.	špecifikácia	Závaž	min.dĺžka (mm)	max. dĺžka (mm)	váha	
26911	hydraulický valec, jednoduchá pumpa	5 000 kg	620	1100	12 kg	2
26912	hydraulický valec, jednoduchá pumpa	8 000 kg	620	1100	13 kg	2
26914	hydraulický valec, dvojité pumpa	5 000 kg	620	1100	12 kg	2
26915	hydraulický valec, dvojité pumpa	8 000 kg	620	1100	14 kg	2



UMÝVAČKA SÚČIASTOK

· Pre bežné umývanie predmetov (súčiastky, diely strojov a pod.)



Č.p.	špecifikácia	Objem vane	Objem čistiacej kvapaliny	Prietok	Max. teplota čistiacej kvapaliny	váha	
26961	myčka součástek	90 l	45 l	10-12 l/min.	50°C	25 kg	1
26963	myčka součástek	180l	150 l	20 l/min	50°C	42 kg	1

ODSÁVAČKA VYJAZDENÉHO OLEJA

- Olej sa z motora vypúšťa do vypúšťacej vaničky, odkiaľ steká do zásobníka
- Nádoba je navyše vybavená pneumatickou odsávačkou
- Vyprázdňovanie zásobníka sa vykonáva pneumaticky jeho pripojením na stlačený vzduch



Č.p.	objem	max.tlak	váha	
26954	90 l	0,5 MPa	28 kg	1



ŠTAHOVÁK NA LOŽISKÁ - DVOJRAMENNÉ



ŠTAHOVÁK NA LOŽISKÁ - TROJRAMENNÝ



Č.p.	max. priemer	hlbka	
23734	Ø 100 mm	50-95 mm	1
23735	Ø 150 mm	100-150 mm	1
23736	Ø 200 mm	110-190 mm	1

Č.p.	max. priemer	hlbka	
23730	Ø 100 mm	50-95 mm	12
23731	Ø 150 mm	100-150 mm	2
23732	Ø 200 mm	110-190 mm	2

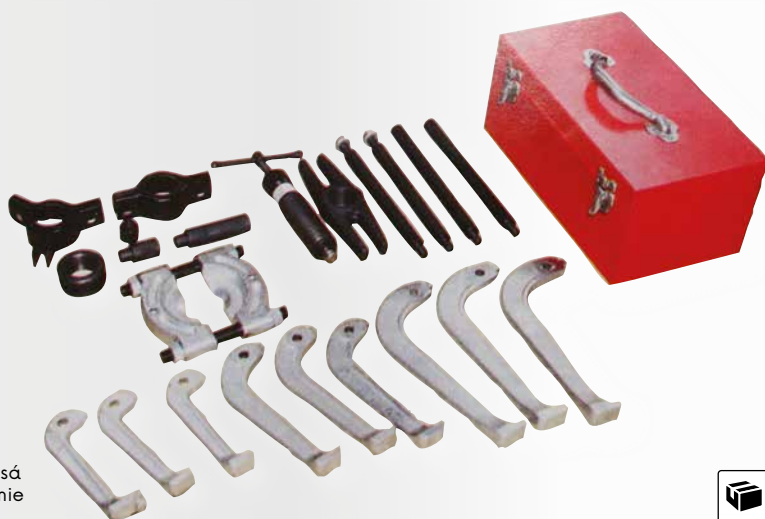

HYDRAULICKÝ ŠTAHOVÁK

- Sada s hydraulickým ťahovákom na ložiská, náboje kolies, ozubené kolesá
- Obsahuje hydraulický skrutku, strmeň, separátor, ťažné skrutky + predĺženie
- V kovovom kufri



Č.p.	špecifikácia	Zaťaž	váha	
26891	univerzální sada hydraulických ťahováků	12 000 kg	18 kg	1



NÁHRADNÉ DIELY K
PIESKOVACIE KABÍNE

Č.p.	rozméry	
26973	rukavice	1
26974	trysky	1
26975	fólie 53,5 x 26 cm	1
26976	plexisklo 60 x 30 cm	1
26977	sklo 60 x 30 cm	1

PIESKOVACÍ KABÍNA 220 L



Č.p.	Spotreba vzduchu	Vonkajšie rozmery	Vnútorné rozmery	max.tlak	váha	
26972	420-710 l/min.	1500 x 830 x 630 mm	600 x 840 x 630 mm	8 bar	38 kg	1

**FESTA****VOZÍK NA NÁRADIE**

Č.p.	Pojazdy zásuviek	Zásuvky	Celkové rozmery	
26986	kluzné	7	680 x 460 x 1020 mm	1

**VOZÍK NA NÁRADIE**

· hornú skrinku možno uložiť do spodného vozíka

Č.p.	špecifikácia	Pojazdy zásuviek	Zásuvky	Vnútorné rozmery zásuviek ŠxHxV	Celkové rozmery	Celková váha	
26985	horná skrinka	kluzné	3	151,5 x 225 x 40 mm	600 x 260 x 340 mm	11,5 kg	1
	spodná skrinka	kluzné	2	511 x 225 x 85 mm 511 x 308 x 85 mm	616 x 330 x 742 mm	16,4 kg	



MAGNETICKÁ MISKA



Č.p.	Špecifikácia	
26996	200 x 20 mm	1



NAPÍNACIE ZARIADENIE



Č.p.	Špecifikácia	
50035	2 t	6
50036	4 t	4



POJAZDNÉ KĽAKADLO



Č.p.	
37135	1



MONTÁŽNE SEDÁTKO

čalúnené pojazdné sedátko
s plastovou odkladacou priehradkou

Č.p.	Špecifikácia	
26988	360 x 365 x 365 mm	1



HYDRAULICKÝ MINI ŽERIAV - MODEL

Č.p.	
26998	1

číslo položky	str.	číslo položky	str.	číslo položky	str.	číslo položky	str.	číslo položky	str.	číslo položky	str.
10002	26	12020	31	13275	51	13452	32	14077	35	15230	40
10003	26	12030	31	13276	52	13453	32	14080	34	15235	40
10005	26	12050	31	13277	55	13454	32	14090	35	15310	40
10008	26	12110	31	13278	51	13455	32	14091	35	15315	40
10025	26	12120	31	13279	50	13456	32	14220	36	15318	40
10033	26	12130	31	13280	51	13457	32	14225	36	15320	40
10035	26	12150	31	13281	55	13458	32	14230	36	15325	40
10043	26	12210	31	13282	55	13459	32	14235	36	15330	40
10045	26	12220	31	13284	50	13460	32	14240	36	15335	40
10048	26	12230	31	13285	55	13461	32	14250	36	15340	40
10110	27	12250	31	13290	92	13462	32	14350	36	15415	41
10120	27	12433	31	13293	92	13463	32	14360	36	15418	41
10130	27	12435	31	13294	92	13464	32	14370	36	15420	41
10330	27	13010	32	13295	57	13465	32	14380	36	15425	41
10332	27	13020	32	13296	57	13466	32	14399	36	15430	41
10334	27	13021	32	13350	56	13467	32	14410	37	15510	41
10336	27	13022	32	13351	56	13468	32	14411	37	15515	41
10430	27	13023	32	13352	56	13469	32	14415	36	15518	41
10450	27	13111	32	13353	56	13470	32	14417	36	15520	41
10490	27	13120	32	13354	56	13471	32	14420	36	15525	41
10996	27	13205	54	13355	56	13472	32	14421	36	15530	41
10998	27	13206	54	13360	56	13473	32	14425	37	15535	41
10999	27	13207	54	13361	56	13500	30	14430	37	15540	41
11002	29	13208	54	13362	56	13501	30	14435	37	15615	41
11003	29	13210	32	13363	56	13502	30	14440	37	15620	41
11005	29	13211	32	13364	56	13503	30	14450	37	15625	41
11006	29	13212	54	13365	56	13504	30	14451	37	15630	41
11007	29	13214	53	13399	33	13505	30	14455	37	15710	41
11008	29	13216	53	13400	33	13506	30	14456	37	15715	41
11082	29	13217	53	13401	32	13507	30	14457	37	15720	41
11083	29	13218	53	13402	32	13508	30	14458	37	15725	41
11085	29	13219	53	13403	32	13509	30	14471	37	15730	41
11102	29	13220	32	13404	32	13510	30	14472	37	15735	41
11103	29	13222	53	13405	32	13511	30	14473	37	15740	41
11105	29	13223	53	13406	32	13512	30	14474	37	15810	42
11106	29	13224	53	13407	32	13513	30	14480	35	15812	42
11107	29	13225	53	13408	32	13514	30	14485	37	15815	42
11110	29	13226	53	13409	32	13515	30	14485	42	15818	42
11200	29	13227	53	13410	32	13516	30	14486	37	15820	42
11201	29	13228	53	13411	32	13517	30	14486	42	15825	42
11202	29	13229	53	13412	32	13518	30	14490	37	15830	42
11204	29	13230	53	13413	32	13519	30	14491	37	15850	42
11205	29	13231	53	13414	32	13520	30	14492	37	15853	42
11206	29	13235	53	13415	32	13521	30	14493	37	15855	42
11207	29	13236	53	13416	32	13522	30	14494	37	15860	42
11208	29	13237	53	13417	32	13523	30	15003	39	15870	42
11209	29	13238	53	13418	32	13524	30	15004	39	15880	42
11210	29	13240	55	13419	32	13525	30	15005	39	15885	259
11220	28	13241	55	13420	32	13526	30	15006	39	15886	259
11221	28	13242	55	13421	32	13527	30	15008	39	15886	383
11226	28	13243	55	13422	32	13528	30	15010	39	15887	259
11239	28	13244	55	13423	32	13529	30	15012	39	15887	383
11259	28	13245	55	13424	32	13530	30	15015	39	15888	259
11260	28	13246	54	13425	32	13531	30	15018	39	15888	383
11311	30	13249	56	13426	32	13532	30	15020	39	15889	259
11312	30	13250	56	13427	32	13533	30	15033	38	15904	43
11313	30	13251	56	13428	32	13534	30	15034	38	15906	43
11314	30	13252	56	13429	32	14001	34	15035	38	15908	43
11323	28	13253	56	13430	32	14002	34	15036	38	15910	43
11325	28	13254	56	13431	32	14003	34	15037	38	15912	43
11327	28	13255	57	13432	32	14004	34	15039	38	15915	43
11333	29	13256	57	13433	32	14006	34	15103	39	15920	43
11335	29	13257	57	13434	32	14007	34	15104	39	15954	43
11337	29	13258	57	13435	32	14008	34	15105	39	15956	43
11338	29	13259	57	13436	32	14009	34	15106	39	15958	43
11343	28	13260	55	13437	32	14010	33	15108	39	15960	43
11345	28	13261	52	13438	32	14011	33	15110	39	15962	43
11347	28	13262	50	13439	32	14012	33	15112	39	15965	43
11353	28	13263	50	13440	32	14013	34	15115	39	15970	43
11355	28	13264	51	13441	32	14015	33	15118	39	15980	44
11356	28	13265	50	13442	32	14017	33	15120	39	15981	44
11358	28	13266	50	13443	32	14019	33	15204	40	15983	31
11360	28	13267	50	13444	32	14025	37	15205	40	15985	31
11410	30	13268	51	13445	32	14030	33	15206	40	15988	31
11416	29	13269	50	13446	32	14035	34	15208	40	15989	31
11420	30	13270	50	13447	32	14040	34	15210	40	15990	44
11425	30	13271	50	13448	32	14045	34	15212	40	15991	44
11444	30	13272	51	13449	32	14060	35	15215	40	15992	44
11445	30	13273	51	13450	32	14070	35	15218	40	15993	44
12010	31	13274	52	13451	32	14075	35	15220	40	15996	42

REGISTER POLOŽIEK



číslo položky	str.	číslo položky	str.	číslo položky	str.	číslo položky	str.	číslo položky	str.	číslo položky	str.
15997	42	16085	167	16991	177	17083	69	17211	73	17351	114
15998	42	16086	167	16991	344	17084	66	17212	74	17352	114
15999	42	16090	165	16998	163	17085	66	17213	74	17353	114
16002	162	16091	165	16999	163	17086	66	17214	74	17357	114
16003	162	16095	167	17001	62	17089	70	17215	74	17359	114
16004	163	16100	164	17002	62	17090	70	17216	75	17360	114
16005	163	16105	164	17003	62	17091	70	17217	75	17361	114
16006	163	16110	164	17004	62	17092	70	17218	75	17380	85
16010	163	16115	164	17005	62	17093	70	17219	75	17381	85
16010	163	16120	164	17006	62	17094	62	17220	77	17382	85
16011	162	16125	164	17007	62	17095	62	17222	77	17383	85
16011	162	16130	166	17008	62	17096	62	17224	77	17384	85
16011	163	16131	164	17009	62	17097	62	17225	76	17385	85
16012	162	16135	166	17010	62	17098	62	17226	76	17386	85
16012	162	16136	165	17011	62	17099	62	17227	76	17390	86
16012	163	16137	165	17012	66	17100	62	17229	78	17391	86
16013	163	16140	166	17013	66	17101	61	17230	79	17392	86
16013	163	16141	169	17014	66	17102	61	17231	79	17393	86
16016	163	16142	165	17015	69	17103	61	17233	79	17394	86
16017	163	16143	165	17016	69	17104	61	17234	79	17395	86
16019	162	16144	165	17017	69	17105	61	17235	80	17396	86
16021	169	16145	165	17019	69	17108	62	17236	80	17397	86
16022	173	16146	166	17020	68	17109	65	17237	80	17398	86
16023	167	16147	166	17021	68	17110	62	17238	110	17400	86
16024	169	16150	164	17022	68	17111	70	17238	78	17401	85
16025	166	16151	164	17023	65	17112	70	17240	81	17402	85
16026	169	16198	176	17024	62	17116	70	17241	81	17405	85
16028	169	16199	176	17025	64	17117	70	17242	81	17406	85
16029	166	16201	173	17026	179	17121	70	17243	81	17407	85
16030	168	16202	63	17027	179	17122	70	17244	81	17410	85
16031	168	16209	175	17028	68	17125	63	17245	78	17411	85
16032	168	16210	174	17029	68	17126	63	17247	111	17412	85
16033	168	16211	174	17033	66	17127	63	17250	77	17413	85
16034	166	16212	173	17034	65	17128	63	17255	77	17414	85
16035	168	16218	174	17035	65	17130	63	17259	111	17415	85
16036	168	16219	174	17036	65	17133	63	17260	110	17416	85
16037	167	16220	174	17037	179	17135	63	17261	91	17420	85
16038	168	16221	174	17038	69	17137	63	17262	91	17421	85
16041	168	16222	175	17039	68	17138	63	17292	81	17422	85
16042	170	16223	175	17040	64	17140	61	17294	81	17427	85
16042	284	16224	175	17041	64	17142	61	17295	81	17450	91
16043	169	16225	173	17042	64	17145	61	17296	81	17451	91
16046	169	16226	175	17043	64	17146	61	17297	81	17455	86
16049	170	16227	175	17044	64	17148	61	17298	81	17456	86
16050	170	16228	175	17045	64	17155	71	17299	81	17458	86
16051	170	16229	173	17046	68	17156	71	17300	69	17459	86
16052	170	16230	173	17047	64	17158	72	17301	69	17460	88
16053	169	16231	127	17048	68	17159	72	17302	69	17461	88
16054	170	16231	173	17050	72	17160	72	17303	69	17462	88
16055	169	16232	65	17050	179	17165	71	17304	69	17463	88
16056	284	16232	176	17051	68	17167	71	17305	69	17464	88
16057	167	16234	173	17052	68	17169	71	17306	69	17465	88
16058	167	16235	174	17053	68	17170	71	17308	82	17466	88
16059	170	16236	174	17054	68	17175	71	17309	82	17467	88
16060	172	16281	177	17055	68	17177	71	17310	82	17468	88
16061	172	16282	177	17056	68	17180	63	17311	82	17469	88
16062	171	16300	180	17057	68	17181	63	17312	82	17470	88
16063	171	16301	180	17058	68	17182	178	17313	82	17471	88
16064	171	16303	180	17059	66	17183	178	17314	82	17472	88
16065	171	16304	180	17060	66	17185	72	17315	82	17473	88
16066	164	16310	180	17061	66	17186	71	17316	82	17475	89
16066	171	16310	180	17062	66	17187	139	17317	82	17476	89
16067	171	16311	180	17063	67	17188	139	17318	82	17480	88
16068	171	16311	180	17064	67	17189	139	17319	82	17481	88
16069	170	16311	180	17065	67	17190	64	17320	82	17482	88
16070	170	16312	180	17066	67	17191	64	17321	82	17483	88
16070	172	16312	180	17067	67	17192	64	17322	82	17484	88
16071	167	16315	179	17068	67	17193	64	17324	82	17485	88
16071	172	16315	179	17069	67	17197	88	17327	82	17486	88
16072	172	16320	180	17070	67	17198	88	17330	82	17487	87
16073	172	16321	143	17071	67	17199	88	17332	82	17488	87
16074	167	16321	180	17072	67	17200	88	17333	82	17489	87
16074	172	16401	72	17075	67	17201	88	17334	82	17490	87
16075	172	16405	72	17076	67	17202	88	17335	77	17491	87
16077	171	16406	72	17077	67	17203	91	17336	77	17492	87
16078	171	16407	72	17078	69	17204	91	17337	77	17493	87
16081	171	16408	72	17079	66	17205	91	17338	77	17494	87
16082	170	16420	72	17080	66	17206	91	17345	76	17495	87
16083	172	16990	177	17081	66	17208	77	17346	76	17496	87
16084	172	16990	344	17082	66	17210	73	17350	114	17501	90

číslo položky	str.	číslo položky	str.	číslo položky	str.	číslo položky	str.	číslo položky	str.	číslo položky	str.
17506	89	17631	87	17851	83	18066	94	18416	99	18607	106
17508	89	17632	87	17852	83	18067	94	18417	99	18608	98
17512	89	17633	87	17853	83	18070	94	18418	97	18610	106
17526	89	17640	90	17854	83	18071	94	18419	99	18611	106
17528	89	17642	90	17855	83	18072	94	18420	99	18612	106
17532	89	17643	90	17856	83	18075	94	18421	109	18613	106
17533	89	17644	90	17860	82	18076	94	18422	95	18614	106
17534	89	17645	90	17861	82	18077	94	18423	96	18615	106
17539	89	17650	90	17862	82	18080	94	18424	95	18618	106
17548	87	17651	90	17863	82	18081	94	18425	98	18619	105
17549	87	17652	90	17864	82	18082	94	18426	96	18619	86
17550	87	17653	90	17865	82	18083	94	18430	109	18620	103
17551	87	17654	90	17866	82	18084	94	18431	99	18621	103
17552	87	17655	90	17867	82	18085	94	18433	98	18623	103
17553	87	17656	90	17868	82	18086	94	18435	100	18625	103
17554	87	17657	90	17869	82	18087	94	18437	96	18627	103
17555	87	17658	90	17870	82	18088	94	18440	109	18628	103
17556	87	17659	90	17871	82	18089	94	18450	98	18630	103
17557	87	17660	87	17872	82	18090	94	18451	98	18631	103
17558	87	17661	87	17873	82	18091	94	18455	94	18632	103
17559	87	17662	87	17874	82	18092	94	18456	94	18632A	102
17560	87	17663	87	17875	82	18101	97	18460	94	18633	103
17561	87	17664	87	17876	82	18102	97	18466	113	18633A	102
17562	87	17665	87	17877	82	18103	97	18468	113	18634	103
17563	87	17666	87	17878	82	18104	97	18476	113	18635	103
17564	87	17667	87	17879	82	18105	97	18477	113	18636	103
17565	87	17668	87	17880	82	18106	97	18490	112	18636A	102
17566	87	17669	87	17881	82	18107	97	18491	112	18637	103
17567	87	17670	87	17882	82	18108	97	18492	112	18637A	102
17568	87	17671	87	17883	82	18110	98	18493	112	18638	103
17569	87	17672	87	17884	82	18113	93	18494	114	18638A	102
17570	87	17674	87	17885	82	18114	93	18495	114	18639	103
17571	87	17675	87	17886	82	18115	93	18496	112	18640	103
17572	87	17676	87	17887	82	18116	93	18497	112	18641	103
17573	87	17677	87	17888	82	18118	93	18498	112	18645	103
17574	87	17678	87	17889	82	18120	93	18499	114	18646	103
17575	87	17679	87	17890	82	18124	93	18500	112	18680	103
17576	87	17680	90	17891	82	18125	93	18508	113	18685	103
17577	87	17681	90	17892	82	18201	97	18510	113	18750	103
17578	87	17682	90	17895	83	18202	97	18511	113	18751	103
17579	87	17683	87	17896	83	18203	97	18512	113	18753	103
17580	87	17685	88	17897	83	18204	97	18513	113	18755	103
17581	87	17761	88	17898	83	18210	93	18514	113	18760	103
17582	87	17769	88	17902	83	18211	93	18515	113	18761	103
17583	87	17788	88	17904	83	18212	93	18516	113	18762	103
17584	87	17789	88	17905	83	18215	93	18518	113	18763	103
17585	87	17795	88	17907	83	18216	93	18519	113	18764	103
17586	87	17806	88	17910	83	18301	97	18520	113	18765	103
17587	87	17810	82	17912	83	18302	97	18521	113	18766	103
17589	87	17811	82	17913	83	18303	97	18522	113	18767	103
17590	87	17812	82	17914	83	18304	97	18523	113	18768	103
17591	87	17820	82	17916	83	18310	93	18524	113	18769	103
17592	87	17821	82	17922	83	18311	93	18527	113	18770	103
17593	87	17822	82	17924	83	18312	93	18548	113	18771	103
17600	91	17823	82	17925	83	18313	93	18559	113	18772	103
17601	91	17824	82	17926	83	18321	93	18562	113	18775	103
17603	91	17825	82	17927	83	18322	93	18567	113	18776	103
17605	88	17826	82	17930	83	18340	95	18572	113	18777	103
17606	88	17827	82	17931	83	18350	94	18575	113	18795	105
17607	88	17828	82	17932	83	18351	94	18576	113	18796	105
17608	88	17829	82	17933	83	18352	94	18577	113	18797	105
17609	88	17830	82	17934	83	18353	94	18578	113	18798	105
17610	88	17831	82	17935	83	18354	94	18579	113	18799	106
17611	88	17832	82	17943	83	18355	94	18580	113	18800	104
17612	88	17835	83	17944	83	18356	94	18581	113	18801	104
17613	88	17836	83	17970	104	18357	94	18582	113	18802	104
17614	88	17837	83	17971	104	18358	94	18583	113	18803	104
17615	88	17838	83	17972	104	18359	94	18584	113	18804	104
17616	88	17839	83	17973	104	18360	94	18585	113	18805	104
17617	88	17840	83	17974	104	18400	97	18586	113	18806	104
17620	90	17841	83	17975	104	18401	97	18587	113	18807	104
17621	90	17842	83	17976	104	18402	95	18588	113	18810	104
17622	87	17843	83	17980	104	18403	95	18589	113	18811	104
17623	87	17844	83	17981	104	18404	95	18593	113	18812	104
17624	87	17845	83	17982	104	18408	100	18600	105	18813	104
17625	87	17846	83	17983	104	18409	100	18601	105	18814	104
17626	87	17847	83	18062	94	18410	96	18602	106	18815	104
17628	87	17848	83	18063	94	18411	96	18603	81	18816	104
17629	87	17849	83	18064	94	18413	96	18604	86	18817	104
17630	87	17850	83	18065	94	18415	99	18605	106	18820	104

REGISTER POLOŽIEK



číslo položky	str.	číslo položky	str.	číslo položky	str.	číslo položky	str.	číslo položky	str.	číslo položky	str.
18821	104	18957	84	19115	142	19410	126	19537	185	19607	185
18822	104	18960	84	19124	118	19410	202	19538	185	19608	185
18823	104	18961	84	19136	118	19411	126	19539	185	19609	185
18824	104	18963	84	19148	118	19411	202	19540	185	19610	185
18825	104	18971	84	19149	118	19412	126	19540	185	19610	185
18826	104	18993	107	19150	117	19412	202	19541	185	19611	185
18827	104	18994	107	19151	117	19415	125	19542	185	19612	185
18827A	102	19001	116	19200	120	19416	125	19543	185	19613	185
18828	104	19002	116	19202	120	19418	126	19544	185	19614	185
18828A	102	19003	116	19208	121	19418	202	19545	185	19615	185
18829	104	19004	116	19209	121	19419	126	19545	185	19615	185
18830	104	19005	116	19211	121	19419	202	19546	185	19616	185
18830A	102	19006	116	19245	120	19421	125	19547	185	19617	185
18831	104	19008	116	19246	120	19422	125	19548	185	19618	185
18831A	102	19010	116	19247	120	19423	125	19550	185	19619	185
18832	104	19015	116	19248	120	19424	125	19550	185	19620	185
18835	104	19020	116	19249	120	19425	125	19552	185	19620	185
18836	104	19021	116	19251	121	19426	125	19552	185	19621	185
18837	104	19022	116	19252	121	19427	125	19553	185	19622	185
18838	104	19023	116	19253	121	19429	202	19554	185	19623	185
18839	104	19024	116	19254	120	19430	119	19555	185	19624	185
18840	104	19025	116	19255	120	19431	119	19555	185	19625	185
18841	104	19026	116	19265	120	19432	119	19556	185	19625	185
18842	104	19028	116	19270	120	19433	119	19557	185	19626	185
18843	104	19030	116	19271	120	19434	119	19558	185	19627	185
18844	104	19031	116	19272	120	19435	119	19558	185	19628	185
18845	104	19032	116	19290	120	19436	126	19559	185	19629	185
18846	104	19034	116	19293	120	19436	202	19560	185	19630	185
18847	104	19036	116	19294	120	19440	119	19560	185	19630	185
18850	104	19041	115	19295	120	19441	119	19561	185	19631	185
18851	104	19042	115	19297	121	19442	119	19562	185	19632	185
18852	104	19043	115	19301	123	19443	119	19562	185	19633	185
18853	104	19044	115	19303	118	19450	127	19563	185	19634	185
18855	104	19045	115	19306	123	19451	127	19564	185	19635	185
18856	104	19046	115	19308	123	19455	127	19565	185	19635	185
18860	104	19050	116	19310	123	19457	127	19565	185	19636	185
18861	104	19051	118	19312	123	19458	128	19567	185	19637	185
18862	104	19052	118	19314	123	19459	128	19568	185	19638	185
18863	104	19053	116	19326	123	19460	126	19568	185	19639	185
18864	104	19054	116	19328	123	19462	124	19569	185	19640	185
18865	104	19055	116	19330	123	19463	124	19570	185	19640	185
18866	104	19056	116	19332	123	19464	124	19570	185	19641	185
18867	104	19057	116	19333	123	19465	124	19573	185	19642	185
18868	105	19058	116	19335	123	19469	124	19574	185	19643	185
18869	105	19059	116	19337	123	19470	126	19575	185	19644	185
18870	105	19060	118	19340	122	19472	203	19575	185	19645	185
18871	105	19061	117	19356	124	19473	203	19576	185	19645	185
18872	105	19062	117	19357	124	19474	203	19577	185	19646	185
18873	105	19063	117	19370	123	19477	203	19578	185	19647	185
18874	105	19064	117	19371	123	19478	203	19579	185	19648	185
18900	108	19065	118	19374	124	19480	203	19580	185	19649	185
18901	108	19066	116	19380	122	19481	203	19580	185	19650	185
18905	108	19067	116	19381	122	19482	203	19581	185	19650	185
18906	108	19068	116	19382	122	19483	203	19583	185	19651	185
18907	109	19069	116	19383	122	19485	202	19584	185	19652	185
18909	108	19070	116	19384	122	19486	202	19585	185	19653	185
18910	100	19071	116	19385	122	19487	202	19585	185	19654	185
18915	109	19074	115	19387	122	19490	127	19586	185	19655	185
18916	109	19075	115	19388	122	19491	127	19587	185	19656	185
18920	84	19076	115	19389	122	19492	127	19588	185	19657	185
18921	84	19077	115	19390	123	19493	127	19589	185	19658	185
18922	84	19081	115	19391	122	19494	127	19590	185	19659	185
18925	84	19082	115	19392	123	19495	127	19590	185	19660	185
18926	84	19083	115	19393	124	19496	127	19591	185	19661	185
18927	84	19084	115	19394	124	19497	127	19593	185	19662	185
18928	84	19085	115	19395	124	19498	127	19594	185	19663	185
18929	84	19086	115	19396	124	19499	127	19595	185	19664	185
18930	84	19088	115	19397	124	19501	127	19595	185	19665	185
18931	84	19090	115	19398	119	19502	127	19596	185	19669	185
18934	84	19092	115	19399	119	19510	128	19597	185	19670	186
18937	84	19095	115	19400	126	19515	128	19598	185	19671	186
18939	84	19096	115	19401	126	19520	128	19599	185	19672	186
18944	84	19097	115	19402	126	19530	185	19600	185	19673	186
18945	84	19098	115	19403	126	19530	185	19600	185	19673	186
18948	84	19100	117	19404	126	19532	185	19601	185	19674	186
18950	84	19106	115	19405	126	19533	185	19603	185	19675	186
18951	84	19108	115	19406	126	19534	185	19604	185	19676	186
18954	84	19109	115	19407	126	19535	185	19605	185	19677	186
18955	84	19110	128	19408	126	19535	185	19605	185	19678	186
18956	84	19115	118	19409	126	19536	185	19606	185	19678	186

číslo položky	str.	číslo položky	str.	číslo položky	str.	číslo položky	str.	číslo položky	str.	číslo položky	str.
19679	186	19743	186	20235	187	20493	191	20767	194	20942	197
19680	186	19743	186	20240	187	20494	191	20768	194	20943	197
19681	186	19744	186	20245	187	20495	191	20769	194	20944	197
19682	186	19745	186	20250	187	20496	191	20770	194	20945	197
19683	186	19746	186	20255	187	20508	195	20771	194	20946	197
19683	186	19747	186	20260	187	20510	195	20772	194	20947	197
19684	186	19748	186	20270	187	20511	195	20773	194	20948	197
19685	186	19748	186	20280	187	20512	195	20774	194	20949	197
19686	186	19749	186	20290	187	20513	195	20775	194	20950	196
19687	186	19750	186	20296	187	20514	195	20776	194	20952	196
19688	186	19751	186	20300	189	20515	195	20777	194	20954	196
19688	186	19752	186	20305	189	20516	195	20778	194	20956	197
19689	186	19753	186	20310	189	20520	195	20779	194	20957	204
19690	186	19753	186	20311	189	20521	195	20780	194	20958	204
19691	186	19754	186	20315	190	20522	195	20781	194	20960	209
19692	186	19755	186	20316	189	20523	195	20782	194	20961	209
19693	186	19756	186	20317	189	20524	195	20783	194	20963	209
19693	186	19757	186	20320	190	20525	195	20784	194	20965	209
19694	186	19758	186	20321	190	20526	195	20785	194	20966	209
19695	186	19758	186	20333	188	20673	194	20786	194	20967	90
19695	186	19759	186	20334	188	20674	194	20787	194	20968	90
19696	186	19760	186	20335	188	20675	194	20788	194	20969	90
19697	186	19761	186	20336	188	20676	194	20789	194	20970	209
19698	186	19762	186	20337	188	20677	194	20790	194	20971	209
19698	186	19763	186	20338	188	20678	194	20791	194	20972	209
19699	186	19763	186	20350	203	20680	194	20792	194	20973	209
19700	186	19764	186	20360	180	20682	194	20793	194	20980	204
19701	186	19765	186	20361	180	20684	194	20794	194	20981	204
19701	186	19766	186	20363	71	20685	194	20795	194	20982	204
19702	186	19767	186	20365	209	20686	194	20796	194	20983	204
19703	186	19768	186	20379	199	20687	194	20797	194	20984	204
19703	186	19768	186	20380	190	20688	194	20798	194	20990	197
19704	186	19769	186	20381	208	20690	194	20799	194	20991	197
19705	186	19770	186	20385	193	20691	194	20805	195	20992	197
19705	186	19771	186	20386	193	20692	194	20820	195	20999	195
19706	186	19772	186	20387	193	20694	194	20825	194	21010	236
19707	186	19772	186	20390	193	20696	194	20855	194	21011	236
19708	186	19773	186	20391	193	20697	194	20861	194	21012	236
19708	186	19774	186	20395	193	20698	194	20862	194	21015	236
19709	186	19775	186	20396	193	20724	204	20870	194	21018	236
19710	186	19776	186	20397	193	20725	204	20871	194	21023	236
19711	186	19776	186	20400	187	20726	204	20872	194	21110	236
19711	186	19777	186	20401	187	20727	204	20873	194	21111	236
19712	186	19778	186	20402	187	20728	204	20874	194	21112	236
19713	186	19779	186	20403	187	20729	204	20875	194	21115	236
19713	186	19780	186	20404	187	20730	204	20876	194	21118	236
19714	186	19781	186	20405	187	20731	204	20877	194	21123	236
19715	186	19781	186	20406	187	20732	204	20878	194	21130	236
19716	186	19782	186	20407	187	20733	204	20879	194	21135	236
19717	186	19783	186	20408	187	20734	204	20880	194	21140	236
19718	186	19783	186	20409	187	20735	204	20881	194	21150	236
19718	186	19784	186	20410	187	20736	204	20890	195	21180	236
19719	186	19785	186	20411	187	20737	204	20891	195	21190	236
19720	186	19786	186	20412	187	20738	204	20895	195	21192	239
19721	186	19786	186	20413	187	20739	204	20896	204	21194	239
19722	186	19787	186	20414	187	20740	204	20897	204	21195	237
19723	186	19788	186	20415	187	20741	204	20898	204	21200	234
19723	186	19789	186	20416	187	20743	106	20899	204	21201	234
19724	186	19790	186	20417	187	20743	197	20901	205	21203	234
19725	186	19791	186	20418	187	20744	197	20905	204	21204	234
19726	186	19792	186	20419	187	20744	208	20910	204	21210	234
19727	186	19793	186	20420	187	20745	208	20911	204	21211	234
19728	186	19794	186	20421	187	20748	194	20912	204	21212	234
19728	186	19795	186	20422	187	20749	194	20913	204	21215	234
19729	186	19796	186	20423	187	20750	194	20915	204	21218	234
19730	186	19797	186	20424	187	20751	194	20916	204	21219	234
19731	186	19798	186	20425	187	20752	194	20917	204	21220	234
19732	186	19799	186	20426	187	20753	194	20918	204	21223	234
19733	186	19800	186	20427	187	20754	194	20919	204	21224	234
19733	186	19801	186	20428	187	20755	194	20920	204	21301	235
19734	186	19802	186	20429	187	20756	194	20921	204	21303	235
19735	186	19841	187	20430	187	20757	194	20922	204	21306	239
19736	186	19842	187	20450	205	20758	194	20923	204	21308	239
19737	186	19845	187	20460	205	20759	194	20924	204	21311	235
19738	186	19885	187	20487	191	20760	194	20936	196	21312	235
19738	186	19895	187	20488	191	20761	194	20937	197	21315	235
19739	186	20210	205	20489	191	20762	194	20938	197	21318	235
19740	186	20220	187	20490	191	20764	194	20939	197	21323	235
19741	186	20225	187	20491	191	20765	194	20940	197	21324	235
19742	186	20230	187	20492	191	20766	194	20941	197	21326	235

REGISTER POLOŽIEK



číslo položky	str.	číslo položky	str.	číslo položky	str.	číslo položky	str.	číslo položky	str.	číslo položky	str.
21327	235	21803	240	22031	212	22113	218	22222	238	22535	184
21410	235	21804	240	22032	212	22115	218	22224	238	22540	184
21411	235	21810	216	22033	213	22116	218	22225	238	22542	184
21412	235	21811	216	22034	213	22117	218	22228	238	22545	184
21415	235	21812	216	22035	213	22120	219	22229	238	22548	184
21418	235	21813	216	22036	213	22121	219	22230	239	22550	184
21423	235	21814	216	22037	211	22122	219	22232	239	22555	184
21424	235	21831	216	22038	211	22123	219	22234	239	22560	184
21425	237	21832	216	22039	211	22124	219	22236	239	22565	184
21426	237	21834	216	22040	211	22125	219	22238	239	22568	184
21427	237	21850	218	22041	214	22126	219	22240	238	22570	184
21428	237	21851	218	22042	214	22129	219	22242	238	22575	184
21430	237	21852	218	22043	214	22130	219	22244	238	22580	184
21431	237	21853	218	22044	214	22132	219	22246	238	22585	184
21432	237	21854	218	22045	216	22133	219	22248	238	22590	184
21440	204	21855	218	22046	216	22134	219	22251	238	22595	184
21441	204	21856	218	22047	216	22135	381	22252	238	22600	184
21442	204	21857	218	22048	216	22136	381	22253	238	22602	184
21443	204	21858	218	22049	216	22137	381	22254	238	22605	184
21444	204	21859	218	22050	216	22138	381	22255	238	22610	184
21445	204	21860	218	22051	216	22140	241	22258	238	22615	184
21446	204	21861	218	22052	216	22141	241	22259	238	22620	184
21450	205	21862	218	22053	216	22142	241	22260	238	22625	184
21451	205	21863	218	22054	216	22143	241	22263	238	22630	184
21452	205	21864	218	22055	216	22145	241	22264	238	22701	214
21453	206	21900	210	22056	216	22146	241	22266	238	22702	214
21454	206	21901	210	22057	216	22147	241	22269	238	22703	214
21530	205	21902	210	22058	212	22148	241	22270	238	22704	214
21540	206	21903	210	22059	212	22150	241	22273	238	22705	214
21541	206	21904	210	22060	214	22151	241	22274	238	22706	214
21701	217	21905	210	22061	214	22155	241	22275	238	22707	214
21702	217	21906	210	22062	214	22156	241	22277	238	23000	400
21703	217	21907	211	22063	214	22158	213	22280	238	23001	400
21704	217	21908	211	22064	214	22159	213	22281	238	23005	402
21705	217	21909	211	22065	215	22160	216	22285	239	23006	402
21706	217	21910	211	22066	215	22161	216	22286	239	23010	402
21709	217	21911	211	22067	217	22162	216	22294	239	23020	402
21715	217	21912	211	22068	215	22163	216	22300	222	23025	402
21716	217	21913	211	22069	215	22164	216	22301	222	23030	402
21717	217	21914	211	22070	215	22166	216	22302	222	23035	402
21718	217	21920	210	22071	215	22167	216	22303	222	23040	402
21719	217	21925	210	22072	215	22168	216	22305	222	23050	402
21720	217	21926	210	22073	214	22170	221	22307	222	23060	402
21721	217	21930	212	22074	214	22171	221	22309	222	23070	402
21724	217	21931	212	22075	217	22172	221	22310	222	23125	401
21732	217	21935	212	22076	217	22173	221	22311	222	23130	401
21734	217	21936	212	22077	217	22174	221	22312	222	23135	401
21735	217	21937	212	22078	213	22178	220	22313	222	23140	401
21736	217	21940	212	22079	213	22180	220	22314	222	23150	401
21737	217	21941	212	22080	213	22181	220	22315	222	23160	401
21740	217	22001	210	22081	213	22182	220	22317	222	23211	401
21741	217	22002	210	22082	213	22183	220	22318	222	23212	401
21742	217	22003	210	22083	215	22184	220	22319	222	23213	401
21743	217	22004	211	22084	215	22185	220	22320	222	23214	401
21744	217	22005	211	22085	215	22186	220	22322	222	23215	401
21750	217	22006	211	22086	213	22188	221	22324	222	23220	401
21751	217	22007	210	22087	214	22189	221	22326	222	23225	401
21752	217	22008	210	22088	215	22190	221	22328	222	23232	401
21753	217	22009	210	22090	215	22195	221	22329	222	23240	401
21754	217	22010	210	22091	215	22197	221	22332	222	23250	401
21780	241	22011	210	22092	215	22198	221	22333	222	23260	401
21781	241	22012	211	22093	215	22199	221	22335	222	23261	401
21782	241	22013	211	22095	215	22200	199	22337	222	23262	401
21783	241	22014	211	22096	216	22201	199	22340	222	23263	401
21784	241	22015	211	22097	216	22202	221	22343	222	23264	401
21786	241	22016	211	22098	216	22203	221	22345	222	23265	401
21787	241	22017	211	22099	216	22204	221	22350	222	23266	401
21788	241	22018	212	22100	218	22205	221	22351	222	23274	401
21789	241	22019	212	22101	218	22206	220	22355	222	23275	401
21790	241	22020	212	22102	218	22207	220	22357	222	23281	403
21792	241	22021	212	22103	218	22208	220	22365	222	23282	403
21793	241	22022	212	22104	218	22209	220	22370	222	23284	403
21794	241	22023	211	22105	218	22211	238	22398	222	23287	402
21795	241	22024	211	22106	218	22212	238	22399	222	23288	402
21796	241	22025	211	22107	218	22215	238	22510	184	23290	403
21798	215	22026	212	22108	218	22216	238	22515	184	23291	403
21798	241	22027	212	22109	218	22217	238	22520	184	23292	403
21800	240	22028	212	22110	218	22218	238	22525	184	23297	403
21801	240	22029	212	22111	218	22219	238	22530	184	23310	401
21802	240	22030	212	22112	218	22220	238	22532	184	23311	401

číslo položky	str.	číslo položky	str.	číslo položky	str.	číslo položky	str.	číslo položky	str.	číslo položky	str.
23312	401	23735	139	24001	137	24148	230	24483	192	24779	201
23390	403	23736	441	24002	137	24149	230	24650	200	24780	201
23391	403	23736	139	24005	137	24150	231	24655	201	24781	201
23400	133	23760	130	24006	137	24151	231	24658	201	24782	201
23401	133	23761	130	24007	136	24152	232	24670	200	24783	201
23402	133	23762	130	24010	136	24152	339	24671	200	24784	201
23406	133	23763	130	24015	137	24153	228	24672	200	24785	201
23407	133	23764	130	24017	137	24154	231	24673	200	24786	201
23410	133	23800	130	24020	137	24155	233	24674	200	24787	201
23411	133	23810	410	24030	137	24156	233	24675	200	24788	201
23412	133	23814	410	24035	138	24158	233	24676	200	24789	201
23415	133	23816	410	24036	138	24159	219	24690	209	24790	200
23416	133	23818	410	24038	138	24159	233	24691	209	24791	200
23417	133	23820	410	24039	138	24160	227	24695	209	24792	200
23420	133	23824	410	24040	138	24161	227	24700	200	24793	200
23506	132	23826	410	24041	138	24162	227	24701	200	24794	200
23507	132	23828	410	24042	138	24163	227	24702	200	24795	201
23508	132	23830	410	24043	138	24164	227	24703	200	24796	200
23515	132	23840	345	24045	224	24165	227	24704	200	24798	200
23520	132	23845	344	24050	226	24166	227	24705	200	25001	323
23525	132	23846	344	24055	223	24167	227	24706	207	25002	323
23530	132	23847	344	24055	282	24168	227	24712	207	25003	323
23531	132	23850	410	24060	223	24169	227	24713	208	25004	323
23551	132	23854	410	24061	223	24170	229	24714	208	25005	323
23560	131	23856	410	24062	223	24171	230	24715	208	25006	322
23561	131	23858	410	24063	223	24173	231	24716	208	25009	322
23562	131	23860	410	24064	223	24174	233	24717	198	25012	322
23563	131	23864	410	24065	223	24175	233	24718	198	25015	322
23564	131	23865	410	24066	223	24176	233	24719	198	25016	322
23565	131	23866	410	24067	223	24177	233	24720	208	25020	322
23566	131	23868	410	24068	223	24178	233	24721	208	25024	322
23570	131	23870	410	24069	223	24180	228	24722	208	25025	322
23571	131	23875	394	24070	223	24181	233	24723	198	25030	322
23572	131	23880	410	24071	223	24185	227	24725	198	25040	322
23573	131	23882	410	24072	223	24186	227	24726	198	25048	322
23574	131	23884	410	24073	223	24187	227	24727	295	25060	322
23585	132	23904	130	24074	223	24188	227	24728	295	25096	322
23587	132	23906	130	24075	223	24189	227	24729	295	25150	322
23589	132	23908	130	24076	223	24190	219	24730	197	25153	322
23591	132	23910	130	24077	223	24190	233	24731	197	25155	322
23600	132	23912	130	24078	223	24192	227	24732	197	25160	323
23601	132	23914	130	24080	224	24195	227	24735	199	25162	323
23602	132	23920	130	24081	224	24196	227	24736	199	25163	323
23605	132	23922	130	24082	224	24197	227	24737	199	25164	323
23620	132	23923	129	24083	224	24212	414	24738	199	25167	323
23625	132	23924	129	24084	224	24225	414	24739	199	25169	323
23626	132	23925	129	24085	224	24250	414	24740	199	25170	323
23628	132	23927	129	24086	224	24255	414	24741	199	25171	323
23630	132	23928	130	24087	224	24258	414	24743	199	25179	322
23632	132	23945	129	24098	224	24260	414	24745	198	25180	322
23650	134	23950	138	24099	224	24301	225	24746	199	25181	322
23655	134	23951	138	24100	228	24302	225	24747	198	25182	322
23657	135	23952	138	24102	228	24303	225	24748	199	25183	322
23657	278	23953	138	24104	228	24304	225	24749	199	25184	322
23660	134	23954	138	24108	227	24305	225	24750	192	25186	322
23670	131	23955	138	24109	228	24306	225	24751	192	25188	322
23671	131	23960	130	24110	229	24308	226	24752	295	25189	322
23672	131	23961	130	24111	229	24310	226	24753	295	25190	322
23673	131	23962	130	24118	228	24312	226	24755	206	25195	322
23674	131	23963	130	24119	228	24313	226	24756	206	25206	322
23675	131	23964	130	24120	227	24314	227	24757	198	25212	322
23676	131	23965	130	24121	229	24315	226	24758	198	25215	322
23677	131	23966	130	24122	229	24316	226	24759	198	25220	322
23678	131	23967	130	24124	229	24410	192	24760	200	25224	322
23679	131	23970	138	24125	229	24411	192	24761	200	25230	322
23680	131	23971	138	24126	229	24412	192	24762	200	25240	322
23681	131	23972	138	24128	231	24415	207	24763	200	25248	322
23682	131	23973	138	24130	230	24419	192	24764	200	25260	322
23683	131	23974	138	24131	230	24420	192	24765	200	25296	322
23684	131	23975	138	24133	230	24422	192	24766	200	25350	322
23685	131	23976	138	24135	231	24425	192	24767	200	25369	322
23730	441	23977	138	24136	231	24429	192	24768	200	25370	322
23730	139	23978	138	24137	231	24432	192	24769	200	25371	322
23731	441	23979	138	24140	231	24435	192	24770	199	25372	322
23731	139	23985	138	24141	231	24437	192	24771	199	25373	322
23732	441	23986	138	24142	231	24444	192	24772	199	25374	322
23732	139	23987	138	24143	230	24451	192	24773	199	25376	322
23734	441	23988	138	24144	230	24457	192	24774	199	25378	322
23734	139	23989	138	24145	230	24464	192	24776	200	25379	322
23735	441	24000	137	24147	230	24476	192	24778	201	25380	322

REGISTER POLOŽIEK



číslo položky	str.	číslo položky	str.	číslo položky	str.	číslo položky	str.	číslo položky	str.	číslo položky	str.
25400	323	26963	440	31146	244	31559	249	32318	257	33257	430
25410	323	26972	441	31148	244	31601	255	32319	257	33258	430
26028	44	26973	441	31150	245	31602	255	32320	257	33270	431
26037	49	26974	441	31151	245	31603	255	32321	257	33275	431
26201	46	26975	441	31155	245	31610	249	32322	257	33275	304
26204	46	26976	441	31218	248	31641	255	32323	257	33280	431
26209	47	26977	441	31220	246	31651	255	32324	257	33285	431
26211	47	26979	443	31221	246	31655	255	32325	258	33286	431
26215	44	26985	442	31222	246	32001	252	32326	258	33289	431
26216	45	26986	442	31231	246	32002	252	32327	256	33291	431
26217	45	26988	443	31232	246	32003	252	32328	258	33292	431
26218	45	26996	443	31233	246	32013	252	32329	257	33293	431
26520	48	26997	443	31234	246	32014	252	32330	258	33298	431
26521	48	26998	443	31235	246	32015	252	32331	258	33299	431
26528	49	28000	4	31270	247	32016	252	32332	256	34005	259
26700	438	28001	5	31271	247	32018	252	32333	256	34006	259
26701	438	28002	5	31280	247	32020	252	32335	258	34007	259
26702	438	28003	6	31281	247	32021	252	32337	256	34027	259
26705	438	28004	6	31320	247	32022	255	32338	256	34028	258
26705	326	28005	7	31322	247	32023	255	32418	257	34033	264
26706	438	28006	7	31330	247	32024	252	32421	257	34041	259
26706	326	28007	8	31332	247	32026	252	33100	426	34051	259
26707	438	28008	8	31334	246	32037	255	33102	426	34053	259
26707	326	28021	9	31340	247	32040	255	33105	426	34061	260
26720	438	28025	9	31341	247	32041	255	33107	426	34071	260
26720	326	28030	12	31343	246	32042	255	33110	426	34081	260
26721	438	28032	12	31360	246	32043	255	33112	426	34091	260
26721	326	28035	14	31362	246	32044	255	33113	426	34101	260
26722	438	28040	13	31380	246	32050	255	33114	426	34111	260
26722	326	28045	13	31382	246	32051	255	33120	426	34115	260
26775	297	28050	15	31390	246	32052	255	33123	426	34116	260
26780	304	28055	15	31392	246	32053	255	33124	426	34117	260
26781	304	28065	11	31400	246	32060	252	33127	427	34118	260
26782	304	28070	10	31402	246	32062	252	33131	427	34121	260
26783	304	28080	18	31403	246	32064	252	33132	427	34122	260
26800	434	28081	18	31404	246	32066	252	33135	427	34132	260
26801	434	28085	18	31452	254	32076	252	33137	427	34142	260
26802	434	28086	18	31453	254	32161	251	33140	427	34152	260
26803	434	28101	16	31454	254	32162	251	33141	427	34153	260
26804	434	28102	17	31455	248	32163	251	33142	427	34154	260
26805	434	28103	17	31456	248	32164	251	33143	427	34155	260
26806	434	28104	16	31461	248	32165	251	33150	427	34156	260
26807	434	30003	259	31467	248	32166	251	33151	427	34157	260
26815	434	30003	264	31468	248	32167	251	33152	427	34158	260
26816	434	30004	259	31471	248	32168	251	33154	427	34159	260
26817	434	30004	264	31481	248	32169	251	33155	430	34160	260
26819	434	30005	259	31491	248	32170	248	33160	428	34200	260
26820	435	30005	264	31493	250	32171	251	33162	428	34201	260
26824	435	30007	259	31494	250	32172	251	33163	428	34202	260
26825	435	30007	264	31495	250	32173	248	33164	428	34203	260
26826	435	31005	245	31496	250	32174	251	33165	428	34221	264
26829	436	31006	245	31497	254	32176	251	33167	428	34223	264
26844	435	31007	245	31498	250	32186	251	33168	428	34231	265
26845	435	31008	245	31499	250	32196	251	33168	257	34235	265
26853	436	31009	245	31500	250	32206	251	33169	428	34237	265
26857	436	31011	245	31501	254	32216	251	33170	428	34238	265
26858	436	31021	245	31502	254	32226	251	33200	429	34241	264
26859	436	31031	245	31503	254	32234	251	33201	429	34243	264
26862	436	31041	245	31505	248	32240	251	33202	429	34251	264
26871	437	31051	245	31506	248	32265	253	33203	429	34261	265
26880	437	31052	246	31507	248	32268	253	33205	429	34262	264
26881	437	31053	245	31510	248	32269	253	33206	429	34265	265
26886	437	31061	246	31511	248	32270	253	33207	429	34271	260
26888	437	31062	246	31512	248	32273	253	33208	429	34272	260
26891	441	31071	246	31513	248	32283	253	33209	429	34273	260
26895	439	31072	246	31514	248	32285	253	33210	429	34274	260
26896	439	31081	246	31515	248	32293	253	33211	429	34275	260
26897	439	31082	245	31520	250	32295	253	33212	429	34276	260
26911	440	31091	244	31521	250	32296	253	33215	429	34280	260
26912	440	31101	244	31522	250	32297	253	33220	430	34281	260
26914	440	31111	244	31523	250	32298	253	33221	430	34282	260
26915	440	31121	244	31524	250	32301	253	33246	431	34283	260
26920	438	31131	244	31541	250	32302	253	33247	431	34284	260
26921	438	31132	244	31551	250	32311	257	33248	431	34285	260
26922	438	31140	244	31552	250	32312	256	33249	431	34300	297
26940	439	31141	244	31553	250	32313	253	33250	430	34301	260
26941	439	31142	244	31555	249	32314	257	33252	430	34303	297
26943	439	31143	244	31556	249	32315	258	33254	430	34304	260
26954	440	31144	244	31557	249	32316	258	33255	430	34305	254
26961	440	31145	244	31558	249	32317	256	33256	430	34306	254

číslo položky	str.	číslo položky	str.	číslo položky	str.	číslo položky	str.	číslo položky	str.	číslo položky	str.
34307	254	35081	268	35517	273	37041	255	37204	286	37500	274
34308	254	35082	269	35518	273	37051	255	37205	286	37501	274
34315	219	35085	267	35519	273	37053	284	37205	286	37505	274
34316	172	35086	267	35524	273	37054	284	37210	285	37506	274
34316	219	35087	267	35525	273	37055	284	37211	285	37509	275
34400	262	35091	267	35527	273	37065	290	37212	286	37510	275
34401	262	35092	267	35532	273	37066	290	37216	298	37511	275
34402	263	35093	267	35533	273	37067	290	37217	298	37512	275
34403	263	35094	267	35539	273	37068	290	37218	298	37515	275
34404	262	35095	267	35540	273	37069	290	37220	285	37516	275
34405	262	35096	267	35542	273	37070	290	37229	299	37517	275
34406	263	35103	270	35552	273	37094	290	37230	299	37518	275
34407	263	35113	270	35553	273	37095	290	37231	299	37527	276
34409	262	35123	270	35555	273	37096	290	37232	299	37530	276
34410	262	35125	270	35603	276	37097	290	37233	299	37532	276
34411	263	35126	270	35604	276	37098	290	37234	299	37533	276
34412	263	35127	270	35605	276	37101	255	37235	299	37539	276
34413	263	35300	266	35833	271	37111	255	37236	298	37541	276
34414	264	35310	266	35845	271	37114	298	37237	298	37545	279
34415	262	35311	266	35850	271	37115	298	37238	298	37546	279
34416	262	35316	266	36014	282	37117	283	37239	298	37549	279
34417	263	35317	266	36024	282	37119	298	37243	321	37553	135
34418	263	35318	266	36034	282	37120	298	37244	321	37553	278
34419	262	35319	266	36035	282	37121	304	37245	321	37560	279
34420	262	35320	314	36036	282	37122	304	37246	321	37564	277
34421	263	35322	314	36046	282	37123	421	37247	321	37570	231
34422	263	35323	181	36056	283	37124	421	37248	321	37570	279
34423	263	35323	294	36057	283	37125	288	37250	321	37600	327
34424	263	35325	181	36058	283	37126	288	37251	321	37601	327
34425	262	35325	294	36059	283	37127	288	37252	321	37602	327
34426	262	35326	181	36076	281	37129	421	37253	321	37603	327
34428	263	35326	294	36077	281	37130	287	37255	308	37604	327
34429	264	35327	181	36080	281	37131	287	37256	308	37605	327
34439	262	35327	294	36081	281	37132	287	37257	308	37606	327
34440	262	35328	181	36082	281	37135	443	37258	308	37611	327
34441	262	35328	294	36085	281	37135	154	37259	308	37615	327
34442	262	35329	181	36086	281	37139	154	37263	308	37616	327
34443	262	35329	294	36087	281	37140	154	37264	308	37621	419
34445	262	35330	183	36126	282	37141	154	37266	308	37630	419
34446	262	35330	293	36128	282	37142	154	37267	308	37640	418
34447	262	35331	183	36130	282	37143	154	37268	308	37641	418
34448	263	35331	293	36136	282	37144	154	37270	308	37645	418
34449	262	35332	182	36140	285	37145	154	37271	308	37650	419
34450	262	35332	292	36145	280	37148	286	37272	308	37730	270
34451	262	35333	182	36160	280	37149	286	37273	308	37731	270
34452	263	35333	292	36175	280	37150	286	37275	308	37760	270
34453	262	35334	182	36190	280	37151	286	37280	309	37761	270
34454	262	35334	292	36191	280	37152	286	37281	309	38000	312
34455	263	35335	181	36199	281	37153	286	37290	321	38001	311
34456	263	35335	294	36200	281	37154	286	37291	321	38002	312
34457	263	35336	182	36240	281	37155	286	37295	410	38003	312
34458	263	35336	292	36300	279	37156	286	37295	309	38004	312
34459	264	35345	183	36305	413	37157	286	37296	410	38005	312
34479	264	35345	293	36306	413	37158	286	37296	309	38006	311
34480	262	35346	183	36308	297	37162	288	37297	410	38007	312
34481	262	35346	293	36310	277	37166	277	37297	309	38008	312
34482	262	35347	183	36312	297	37170	288	37300	158	38009	312
34485	262	35347	183	36313	413	37171	288	37301	158	38010	311
34486	262	35347	293	36314	413	37172	288	37302	158	38012	311
34490	263	35347	293	36325	289	37173	288	37303	158	38013	311
34491	263	35348	182	37005	317	37174	288	37308	159	38014	312
34496	263	35348	292	37006	284	37175	288	37309	159	38014	312
34500	264	35360	144	37006	284	37176	288	37310	157	38015	313
35006	268	35361	144	37007	284	37177	289	37311	157	38016	313
35007	268	35362	144	37007	284	37178	289	37317	337	38017	313
35011	270	35500	272	37008	284	37185	288	37320	157	38018	313
35012	268	35501	272	37009	284	37186	288	37321	157	38020	311
35013	268	35502	272	37010	431	37187	288	37325	156	38021	313
35015	269	35503	272	37011	284	37188	288	37326	156	38022	313
35021	269	35504	272	37012	284	37189	288	37328	156	38024	311
35023	267	35505	272	37021	284	37190	288	37330	155	38025	311
35038	267	35506	272	37025	283	37195	286	37331	155	38026	286
35048	269	35507	272	37025	283	37196	286	37332	155	38026	314
35058	267	35508	272	37026	283	37197	286	37340	159	38027	310
35059	268	35510	272	37026	283	37198	286	37341	158	38028	310
35068	269	35511	272	37028	283	37199	287	37342	158	38030	314
35069	268	35512	272	37028	283	37200	286	37343	159	38031	313
35070	269	35514	273	37029	283	37201	286	37344	159	38042	286
35078	268	35515	273	37029	283	37202	286	37345	159	38042	314
35079	269	35516	273	37031	255	37203	286	37350	157	38050	305

REGISTER POLOŽIEK



číslo položky	str.	číslo položky	str.	číslo položky	str.	číslo položky	str.	číslo položky	str.	číslo položky	str.
38052	305	38980	307	41120	387	42368	305	45019	336	45096	333
38054	305	38981	307	41121	387	42420	296	45020	332	45097	333
38055	305	38985	309	41122	387	43050	395	45021	336	45098	333
38060	305	38990	307	41123	387	43058	396	45023	332	45099	333
38063	305	38991	307	41150	387	43060	396	45025	336	45100	364
38065	305	38995	308	41151	387	43068	396	45026	335	45101	364
38095	305	39000	304	41152	387	43071	395	45027	336	45102	364
38096	305	39001	304	41153	387	43072	395	45029	336	45104	364
38097	305	39002	304	42101	387	43077	395	45030	232	45105	364
38895	291	39003	304	42102	387	43082	396	45030	339	45106	364
38896	291	39005	304	42103	387	43083	396	45031	232	45107	364
38899	291	39010	304	42115	299	43084	396	45031	339	45108	364
38900	291	39012	304	42120	299	43086	396	45032	232	45110	352
38901	291	39014	304	42150	389	43087	397	45032	339	45111	352
38902	291	39020	304	42151	389	43089	397	45033	232	45112	353
38903	291	39021	304	42152	389	43090	397	45033	339	45113	352
38904	291	39045	304	42153	389	43097	396	45034	342	45114	352
38905	291	39065	304	42155	389	43098	397	45035	341	45115	352
38906	291	39090	304	42156	389	43099	397	45036	345	45116	352
38907	291	39145	304	42157	389	43300	385	45038	342	45117	351
38908	291	39165	304	42158	389	43301	385	45039	342	45118	351
38909	291	39190	304	42160	389	44041	345	45040	342	45120	352
38910	291	39192	304	42161	389	44042	345	45041	342	45122	352
38911	291	39192	347	42162	389	44043	345	45042	347	45123	351
38912	291	39193	304	42163	389	44050	345	45043	344	45124	351
38913	291	39193	347	42170	389	44053	347	45044	345	45125	351
38914	291	39194	305	42171	389	44950	176	45045	177	45126	351
38915	291	39195	305	42172	389	44950	340	45045	344	45130	355
38916	291	39196	305	42173	389	44955	342	45046	177	45131	355
38917	291	39197	305	42174	389	44960	347	45046	344	45132	355
38918	291	39198	305	42175	389	44965	368	45047	347	45133	356
38919	285	39199	305	42176	389	44970	336	45048	177	45134	353
38920	285	39200	305	42177	389	44971	336	45048	335	45135	355
38923	285	39201	305	42178	389	44972	332	45048	344	45136	356
38924	307	39202	305	42179	389	44980	332	45049	345	45137	356
38925	307	39203	305	42180	389	44980	332	45050	368	45138	354
38926	309	39204	305	42181	389	44980	334	45051	369	45139	354
38927	307	39205	305	42182	389	44981	332	45052	369	45140	353
38928	308	39206	295	42185	389	44981	332	45053	370	45141	354
38929	307	39207	295	42186	389	44981	333	45054	370	45142	353
38930	309	39208	295	42187	389	44981	334	45055	369	45143	354
38931	307	39210	295	42188	389	44982	333	45056	341	45144	355
38932	307	39212	295	42190	306	44982	333	45057	341	45145	355
38933	309	39214	295	42190	389	44982	334	45058	341	45146	357
38934	308	39216	295	42201	390	44983	333	45059	341	45147	358
38935	309	39217	295	42202	390	44983	333	45060	232	45150	358
38937	309	39218	295	42203	390	44983	334	45060	339	45151	359
38939	309	39219	295	42207	390	44984	334	45061	232	45152	357
38940	309	39238	296	42208	390	44984	335	45061	339	45153	357
38941	309	39240	295	42209	390	44984	335	45062	232	45154	357
38942	308	39241	295	42210	390	44985	334	45062	339	45155	358
38943	309	39242	295	42211	390	44985	335	45063	332	45156	358
38944	306	39243	295	42212	390	44986	334	45065	341	45158	358
38945	306	39244	295	42213	390	44987	334	45066	341	45159	359
38946	306	39245	296	42214	390	44988	334	45067	341	45160	358
38947	306	40050	388	42217	390	44989	334	45068	177	45161	359
38948	306	40051	388	42218	390	44991	334	45068	335	45162	357
38949	306	40052	388	42219	390	44992	334	45068	344	45163	358
38950	296	40053	388	42220	390	44995	338	45069	176	45164	359
38951	296	40054	388	42221	390	44996	334	45069	340	45167	358
38952	296	40055	388	42228	390	44997	335	45070	370	45168	359
38953	296	40056	388	42229	390	44998	335	45071	369	45169	359
38954	296	40057	388	42230	390	44999	337	45074	346	45170	361
38955	306	40058	388	42240	390	45000	337	45079	342	45171	361
38956	306	40059	388	42244	390	45001	337	45080	342	45172	361
38957	306	40060	388	42248	390	45002	338	45081	176	45172	361
38958	306	40075	388	42249	390	45003	338	45081	340	45173	361
38959	306	40076	388	42251	390	45005	338	45082	176	45173	361
38960	306	40077	388	42252	390	45006	338	45082	340	45174	361
38961	306	40100	387	42253	390	45007	338	45083	176	45175	360
38963	309	40120	387	42255	390	45008	338	45083	340	45176	360
38964	307	41050	387	42256	390	45009	338	45084	176	45177	360
38965	308	41080	387	42257	390	45010	335	45084	340	45178	360
38966	307	41081	387	42260	391	45011	337	45085	347	45179	359
38968	307	41082	387	42261	391	45012	337	45086	346	45180	353
38969	309	41083	387	42312	296	45014	335	45088	333	45181	353
38970	296	41100	387	42312	390	45015	337	45089	333	45182	360
38971	296	41101	387	42365	305	45016	336	45093	347	45183	360
38972	309	41102	387	42366	305	45017	334	45094	334	45184	359
38973	309	41103	387	42367	305	45018	335	45095	333	45185	359

číslo položky	str.	číslo položky	str.	číslo položky	str.	číslo položky	str.	číslo položky	str.	číslo položky	str.
45186	359	45296	353	45520	343	45651	345	48415	328	50541	153
45187	360	45297	354	45521	343	45652	345	48420	328	50542	153
45190	362	45298	353	45522	343	45653	345	48452	328	50544	153
45191	362	45299	354	45523	343	45654	345	48453	328	50549	152
45192	362	45300	361	45524	343	45655	345	48454	328	50550	150
45193	362	45301	361	45525	343	45656	345	48455	328	50551	150
45194	362	45320	369	45526	343	45657	345	48456	328	50553	150
45195	362	45321	370	45527	343	45658	345	48457	328	50554	150
45196	362	45323	368	45528	343	45659	345	48719	279	50555	153
45197	362	45323	382	45529	343	45660	345	48729	277	50556	150
45198	362	45325	368	45530	343	45661	345	48730	277	50557	152
45199	362	45326	368	45531	343	45662	345	48731	277	50558	152
45200	362	45327	367	45532	343	45663	345	50004	414	50559	150
45203	363	45328	367	45533	343	45664	345	50005	414	50560	150
45204	363	45329	367	45534	343	45670	345	50009	415	50562	150
45206	362	45330	385	45535	346	45671	345	50010	415	50563	150
45211	363	45331	385	45540	346	45672	345	50011	415	50564	150
45213	355	45345	361	45541	346	45673	345	50012	415	50570	150
45214	357	45349	361	45542	346	48001	145	50013	415	50571	150
45215	356	45350	361	45543	346	48002	145	50014	415	50585	153
45216	357	45353	361	45550	346	48005	146	50015	415	50585	321
45217	357	45360	361	45551	346	48006	146	50017	417	50586	153
45218	356	45364	361	45552	346	48007	146	50019	417	50586	321
45219	356	45366	361	45553	346	48008	147	50020	417	50587	153
45220	363	45370	177	45555	346	48009	147	50021	417	50587	321
45221	363	45370	344	45556	346	48010	147	50022	417	50588	153
45222	363	45385	348	45557	346	48015	145	50025	417	50588	321
45223	363	45386	348	45558	346	48020	146	50026	417	50900	409
45224	363	45388	348	45559	346	48021	146	50030	391	50901	409
45225	363	45389	348	45560	345	48022	146	50031	391	50902	409
45226	363	45390	349	45562	346	48030	146	50032	391	50905	409
45227	363	45391	349	45563	346	48031	147	50033	391	50906	409
45228	363	45392	349	45564	346	48032	147	50035	443	50907	409
45229	363	45393	349	45565	346	48033	147	50035	391	50909	409
45239	366	45394	349	45570	389	48034	147	50036	443	50910	409
45240	366	45395	349	45571	389	48036	145	50036	391	50911	409
45241	366	45396	349	45572	389	48037	146	50037	391	50915	409
45242	366	45397	349	45573	389	48040	147	50038	391	50916	409
45244	365	45398	350	45580	390	48041	147	50040	391	50917	409
45245	365	45399	350	45600	363	48042	147	50041	391	50918	409
45246	365	45400	350	45601	363	48043	147	50042	391	50919	409
45247	365	45401	350	45602	363	48046	146	50050	305	50920	409
45248	365	45450	394	45603	363	48046	147	50050	305	51001	408
45249	365	45451	394	45604	363	48047	146	50051	305	51002	408
45250	365	45452	394	45605	363	48047	147	50052	305	51003	408
45251	365	45453	394	45606	363	48050	148	50052	305	51004	408
45253	365	45460	394	45607	363	48051	148	50100	324	51007	408
45254	365	45461	394	45608	363	48054	148	50101	324	51008	408
45256	365	45462	394	45609	363	48055	148	50102	324	51009	408
45257	365	45463	394	45610	363	48056	148	50103	324	51010	408
45260	365	45465	394	45611	363	48057	148	50104	324	51011	408
45261	365	45466	394	45612	363	48060	148	50106	324	51013	407
45262	365	45467	394	45613	363	48061	148	50108	324	51015	408
45262	366	45470	394	45614	363	48062	148	50500	151	51017	407
45263	365	45471	309	45615	363	48063	148	50501	151	51018	407
45263	366	45471	344	45616	363	48064	148	50502	151	51020	407
45265	366	45472	344	45617	363	48065	148	50503	151	51022	407
45266	366	45473	344	45618	363	48066	148	50505	151	51023	407
45267	365	45480	394	45619	363	48067	148	50510	149	51026	406
45267	366	45485	394	45620	363	48068	148	50511	149	51030	407
45268	365	45490	380	45621	363	48070	148	50512	149	51032	407
45268	366	45496	394	45622	363	48071	148	50513	149	51034	407
45269	366	45497	394	45623	363	48072	148	50514	149	51036	408
45270	365	45498	394	45624	363	48075	148	50518	151	51037	408
45271	365	45499	394	45625	363	48076	148	50519	151	51038	409
45272	365	45500	343	45626	363	48077	148	50520	151	51040	406
45273	365	45502	343	45627	363	48080	148	50521	151	51041	406
45274	365	45503	343	45628	363	48081	148	50522	152	51042	406
45280	364	45505	343	45629	363	48085	148	50523	151	51043	406
45283	364	45506	343	45630	363	48086	148	50524	151	51045	407
45285	364	45508	343	45631	363	48087	148	50525	152	51046	407
45286	364	45509	343	45632	363	48090	148	50526	152	51050	409
45287	364	45511	343	45633	363	48091	148	50527	153	51051	409
45289	355	45512	343	45634	363	48093	148	50529	152	51055	409
45290	355	45513	343	45635	363	48094	148	50531	152	51056	409
45291	355	45515	343	45636	363	48095	148	50532	153	51057	409
45292	356	45516	343	45637	363	48096	148	50533	152	51060	406
45293	356	45517	343	45638	363	48097	148	50537	152	51065	406
45294	354	45518	343	45639	363	48410	328	50539	152	51070	406
45295	354	45519	343	45650	345	48411	328	50540	153	51071	406

REGISTER POLOŽIEK



číslo položky	str.	číslo položky	str.	číslo položky	str.	číslo položky	str.	číslo položky	str.	číslo položky	str.
51072	406	51288	325	52125	385	55041	143	55465	392	61077	380
51100	326	51300	324	52126	385	55050	143	55640	329	61079	380
51101	326	51301	324	52130	285	55051	143	55642	329	61085	342
51102	326	51302	324	52160	382	55060	143	55645	329	61088	374
51103	326	51303	324	52161	382	55080	143	60001	384	61089	373
51104	326	51304	324	52162	382	55100	143	60006	384	61090	374
51105	326	51305	324	52163	382	55120	143	60008	384	61097	376
51106	326	51306	324	52164	382	55140	143	60012	384	61098	376
51107	326	51307	324	52168	381	55160	143	60018	385	61111	378
51108	326	51308	324	52173	381	55180	143	60019	385	61112	378
51109	326	51320	324	52175	381	55181	143	60020	385	61114	378
51110	326	51321	324	52176	381	55200	143	60022	385	61120	378
51111	326	51322	324	52185	382	55201	143	60100	253	61121	378
51120	326	51323	324	52186	382	55220	143	60115	277	61130	369
51121	326	51324	324	52187	382	55221	143	60116	277	61131	369
51122	326	51325	324	52188	382	55240	143	60117	277	61132	369
51123	326	51327	324	52189	382	55300	143	60118	277	61133	369
51124	326	51338	326	52190	382	55301	143	60121	277	61134	370
51125	326	51341	326	52191	382	55311	143	60123	277	61135	370
51126	326	51348	326	52192	382	55313	143	60201	384	61136	367
51127	326	51402	325	52193	382	55314	143	60206	384	61137	367
51130	326	51403	325	52194	382	55315	143	60208	384	61138	367
51131	326	51404	325	52195	383	55316	143	60212	384	61139	368
51132	326	51405	325	52196	383	55317	143	61000	374	61140	368
51181	415	51406	325	52197	382	55318	143	61001	374	61141	370
51182	415	51407	325	52198	381	55319	143	61002	375	61142	370
51187	409	51408	325	52202	316	55331	143	61003	376	61143	371
51196	326	51410	325	52203	316	55332	143	61004	375	61144	371
51197	326	51412	325	52204	316	55333	143	61005	372	61145	371
51198	326	51413	325	52205	316	55334	143	61006	372	61146	371
51199	326	51414	325	52206	316	55335	143	61007	373	61147	367
51200	409	51415	325	52207	316	55336	143	61008	372	61148	367
51201	409	51416	325	52208	316	55337	143	61009	377	61149	368
51202	409	51417	325	52212	316	55339	143	61010	373	61149	382
51203	409	51418	325	52213	316	55340	143	61012	377	61150	369
51204	324	51420	325	52214	316	55341	143	61013	376	61155	372
51205	324	51430	325	52215	316	55342	143	61014	377	61156	372
51206	324	51431	325	52216	316	55350	143	61015	373	61157	372
51207	324	51432	325	52217	316	55351	143	61018	376	61158	372
51208	324	51433	325	52218	316	55352	143	61019	376	61161	375
51209	324	51435	325	52220	316	55353	143	61020	374	61162	376
51210	324	51436	325	52283	316	55354	143	61021	373	61163	376
51211	324	51450	325	52284	316	55355	143	61022	374	61164	377
51212	324	51510	403	52285	316	55356	143	61024	375	61165	377
51220	325	51511	403	52286	316	55357	143	61025	373	61166	377
51221	325	51512	403	52288	316	55358	143	61026	373	61169	253
51222	325	51513	403	52305	319	55359	143	61028	377	61171	385
51225	325	51514	403	52306	319	55360	143	61029	373	61172	382
51226	325	51515	403	52315	319	55361	143	61030	371	61172	385
51227	325	51516	403	52328	319	55362	143	61031	371	61173	385
51241	324	51517	403	52331	319	55400	392	61032	371	61174	385
51242	324	52010	416	52334	319	55401	392	61033	371	61175	385
51243	324	52011	249	52391	319	55402	392	61034	371	61176	385
51244	324	52011	320	52421	319	55403	392	61035	378	61177	385
51245	324	52012	416	52424	319	55404	392	61036	378	61183	386
51246	324	52020	416	52428	319	55405	392	61038	378	61184	386
51247	324	52030	416	52456	319	55406	392	61040	378	61189	386
51257	326	52030	260	52471	319	55420	392	61042	378	61190	386
51258	326	52050	328	52600	318	55421	392	61044	377	61192	385
51259	326	52055	328	52601	318	55422	392	61045	371	61193	385
51260	326	52060	328	52602	318	55423	392	61046	371	61194	385
51261	326	52065	328	52605	318	55424	392	61047	371	61195	386
51262	326	52070	316	52610	318	55425	392	61048	371	61200	385
51263	326	52071	317	52611	297	55429	392	61050	374	61201	385
51264	326	52075	317	52612	297	55430	392	61051	374	61201	385
51265	326	52076	317	52620	321	55431	392	61052	375	61202	386
51271	324	52077	317	52625	321	55432	392	61053	374	61203	377
51272	324	52078	317	52630	321	55433	392	61054	375	61204	386
51273	324	52101	382	52635	321	55436	392	61056	373	61205	386
51274	324	52102	382	52640	321	55437	392	61057	373	61207	386
51275	324	52103	382	52645	321	55450	393	61058	375	61208	386
51276	324	52104	382	52652	321	55452	393	61059	375	61209	377
51278	324	52105	382	52656	321	55453	393	61060	371	61215	386
51280	325	52108	382	52662	320	55454	393	61061	371	61218	253
51281	325	52109	383	52666	320	55455	393	61062	371	61219	386
51282	325	52113	383	52671	320	55456	393	61063	371	61221	379
51283	325	52114	383	52694	320	55457	393	61067	379	61221	379
51284	325	52115	383	52695	320	55460	393	61068	379	61221	379
51286	325	52116	383	54008	321	55461	393	61069	379	61221	379
51287	325	52119	381	55040	143	55462	393	61070	379	61222	377

číslo položky	str.	číslo položky	str.	číslo položky	str.	číslo položky	str.	číslo položky	str.	číslo položky	str.
61223	376	70036	140	81152	424	81267	423	81348	423	81430	423
61224	378	70037	140	81155	424	81268	423	81349	423	81431	423
61224	378	70038	140	81160	425	81269	423	81350	423	81432	423
61230	386	70040	140	81165	425	81270	423	81351	423	81433	423
61235	416	70045	140	81170	424	81271	423	81352	423	81434	423
61240	118	70046	140	81175	425	81272	423	81353	423	81435	423
61250	386	70060	141	81178	425	81273	423	81354	423	81436	423
61251	347	70061	141	81180	425	81274	423	81355	423	81437	423
61251	386	70062	141	81185	424	81275	423	81356	423	81438	423
61252	386	70063	141	81186	424	81276	423	81357	423	81439	423
61253	386	70064	141	81189	424	81277	423	81358	423	81440	423
61254	386	70065	142	81190	425	81278	423	81359	423	81441	423
61255	386	70066	141	81191	425	81279	423	81360	423	81442	423
61256	386	70070	142	81200	423	81280	423	81361	423	81443	423
61290	379	70075	142	81201	423	81281	423	81362	423	81444	423
61291	379	70090	142	81202	423	81282	423	81363	423	81445	423
61292	379	70091	142	81203	423	81284	423	81364	423	81447	423
61293	379	70092	142	81204	423	81285	423	81365	423	81448	423
61294	379	70093	142	81205	423	81286	423	81366	423	81449	423
61295	379	70094	142	81206	423	81287	423	81367	423	81450	423
61296	379	70095	142	81207	423	81288	423	81370	423	81451	423
61297	379	70096	142	81208	423	81289	423	81371	423	81452	423
61299	393	70098	92	81209	423	81290	423	81372	423	81453	423
61300	393	70100	405	81210	423	81291	423	81373	423	81454	423
61301	393	70101	405	81211	423	81292	423	81374	423	81455	423
61302	393	70102	405	81212	423	81293	423	81375	423	81456	423
61320	119	70103	405	81213	423	81294	423	81376	423	81457	423
61321	119	70104	405	81214	423	81295	423	81377	423	81458	423
61322	119	70105	405	81215	423	81296	423	81378	423	81459	423
61323	119	70106	405	81216	423	81297	423	81379	423	81460	423
61324	119	70107	405	81217	423	81298	423	81380	423	81461	423
61325	119	70108	405	81218	423	81299	423	81381	423	81462	423
61326	119	70109	405	81219	423	81300	423	81382	423	81463	423
61327	119	70110	405	81220	423	81301	423	81383	423	81466	423
61328	119	70120	404	81221	423	81302	423	81384	423	81467	423
61329	119	70121	404	81222	423	81303	423	81385	423	81468	423
61330	119	70122	404	81223	423	81304	423	81386	423	81469	423
61331	119	70123	404	81224	423	81305	423	81387	423	81470	423
61340	123	70124	404	81225	423	81306	423	81388	423	81471	423
61341	123	70125	404	81226	423	81307	423	81389	423	81472	423
61342	123	70140	404	81227	423	81308	423	81390	423	81473	423
61343	123	70141	404	81228	423	81309	423	81391	423	81486	423
61344	123	70220	414	81229	423	81310	423	81392	423	81600	421
61345	123	70221	414	81230	423	81311	423	81393	423	81603	421
61346	123	81011	422	81231	423	81312	423	81394	423	82105	299
65062	329	81011A	422	81232	423	81313	423	81395	423	89970	411
65063	329	81011F	422	81233	423	81314	423	81396	423	89970	315
65064	329	81011G	422	81234	423	81315	423	81397	423	89973	411
65065	329	81011H	422	81235	423	81316	423	81398	423	89973	315
69900	301	81011R	422	81236	423	81317	423	81399	423	89975	411
69901	301	81012	422	81237	423	81318	423	81400	423	89975	315
69902	301	81013	422	81238	423	81319	423	81401	423	89980	411
69903	301	81014	422	81239	423	81320	423	81402	423	89980	315
69904	300	81015	422	81240	423	81321	423	81403	423	89985	411
69905	301	81016	422	81241	423	81322	423	81404	423	89985	315
69906	301	81022	422	81242	423	81323	423	81405	423	89987	411
69907	303	81023	422	81243	423	81324	423	81406	423	89987	315
69908	303	81024	422	81244	423	81325	423	81407	423	89988	411
69909	303	81025	422	81245	423	81326	423	81408	423	89988	315
69910	302	81035	422	81246	423	81327	423	81409	423	89989	411
69911	302	81036	422	81247	423	81328	423	81410	423	89989	315
69912	302	81053	420	81248	423	81329	423	81411	423	89990	411
69914	301	81054	420	81249	423	81330	423	81412	423	89990	315
69917	302	81056	420	81250	423	81331	423	81413	423	90070	283
69918	300	81057	420	81251	423	81332	423	81414	423	90071	283
69919	300	81070	420	81252	423	81333	423	81415	423	90072	283
69920	303	81071	420	81253	423	81334	423	81416	423	90191	185
69923	303	81072	420	81254	423	81335	423	81417	423	90192	186
69928	303	81074	420	81255	423	81336	423	81418	423		
69930	302	81075	420	81256	423	81337	423	81419	423		
69931	302	81077	420	81257	423	81338	423	81420	423		
70020	140	81100	420	81258	423	81339	423	81421	423		
70021	140	81101	420	81259	423	81340	423	81422	423		
70025	140	81102	420	81260	423	81341	423	81423	423		
70026	140	81103	420	81261	423	81342	423	81424	423		
70030	140	81104	420	81262	423	81343	423	81425	423		
70031	140	81105	420	81263	423	81344	423	81426	423		
70032	140	81106	420	81264	423	81345	423	81427	423		
70033	140	81150	424	81265	423	81346	423	81428	423		
70035	140	81151	424	81266	423	81347	423	81429	423		

GRAFICKÉ SYMBOLY POUŽITÉ V KATALÔGU

ŠPECIFIKÁCIA PRODUKTOV



- S2** · funkčné časti z vysoko legovanej nástrojovej ocele S2
- HSS** · funkčné časti vyrobené z rýchloreznej ocele
- Cr-Mo** · funkčné časti z chróm-molybdénovej ocele
- CrV** · funkčné časti z chróm-vanádiovej ocele
- INOX** · funkčné časti z nehrzdavejúcej ocele
- NYLON** · nylonová rukoväť
- TEFLON** · teflónový povrch
- Zn** · zinkované
- TiN** · povrch potiahnutý nitridom titánu
- HRC 58-61** · tvrdosť materiálu funkčných častí podľa Rockwella
- 40% PES** · zloženie materiálu - obsahuje 40% polyesteru
- PES** · zloženie materiálu - vyrobené z polyesteru
- DIAMANT** · diamantové zrná na povrchu funkčných častí
- MAGNETICKÉ** · magnetické

- SDS+** **SDS MAX** **M14** · spôsob uchytenia
- 72T** **36T** · počet zubov račne
- 1/2"** **3/4"** **1/4"** · veľkosť uchytenia
- 27 dB** · údaj o výške ochrany sluchu
- DIN 3113** **IP 54** · spĺňa uvedenú normu
- 32x** · počet produktov v sade
- II. class** **III. class** · spĺňa uvedenú triedu presnosti
- SNOW** · vhodné do chladného počasia
- ERGO HANDLE** · ergonomická rukoväť
- HOBBY** · pre hobby použitie
- 2x AAA** · počet a typ batérií
- UV STABLE** · odolné proti UV žiareniu
- RUBBER ENDS** · nárazuvzdorné gumené koncovky

ŠPECIFIKÁCIA POUŽITIA

- drevo ·
- keramika ·
- plasty ·
- hliník · **ALU**
- meď · **Cu**
- kameň ·
- sklo ·
- murivo ·
- papier ·
- ocel ·
- kompozit ·
- obklady ·
- nerezová ocel · **INOX**
- omietka ·
- drevo so skrutkami, klincami ·
- sadrokartón · **DRYWALL**
- pre vŕtanie do materiálov · **900 MPa**
s pevnosťou v ťahu do ...



ŠPECIFIKÁCIA BALENIA

- balené v krabici
- balenie so závesom
- MOQ 12** · minimálne objednávatel'né množstvo
- 5** · počet kusov v balení

ŠPECIFIKÁCIA PRODUKTOV VODNÉHO PROGRAMU

voliteľný tvar prúdu vody ·

minimálny a maximálny tlak ·

maximálny prietok vody ·

zavlažovaná plocha ·

veľkosť závitú pre pripojenie adaptéra ·

priemer hadice pre pripojenie do rýchlospojky ·



20

23

24

FESTA[®]

PROFESIONÁLNE X NÁRADIE



festatools



#festatools



festatools

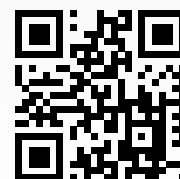

www.festa.tools

HORIZONT.

FESTA
POWER X TOOLS

FESTA
AQUATIC

ROSA KOMELON.

KDS

Stahlberg

SUPER PRO

Lescha

